

Part List Mechanical

Applicable for J300

1	Exploded view	2
1.1	Exploded view phone	2
2	Part List	4
2.1	Part list phone	4
3	Label Part List.....	5
4	Revision History	5



1 Exploded view

1.1 Exploded view phone

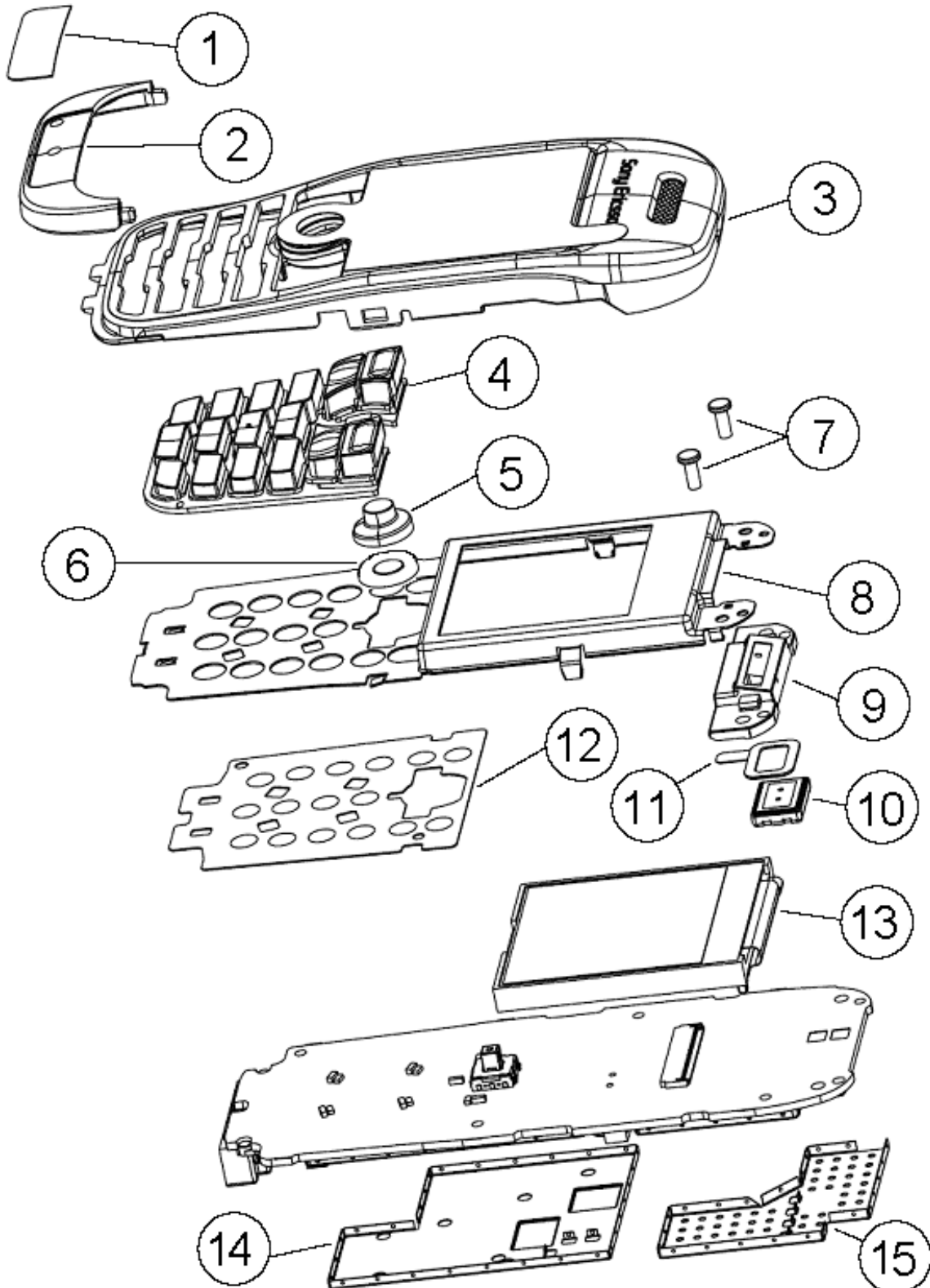

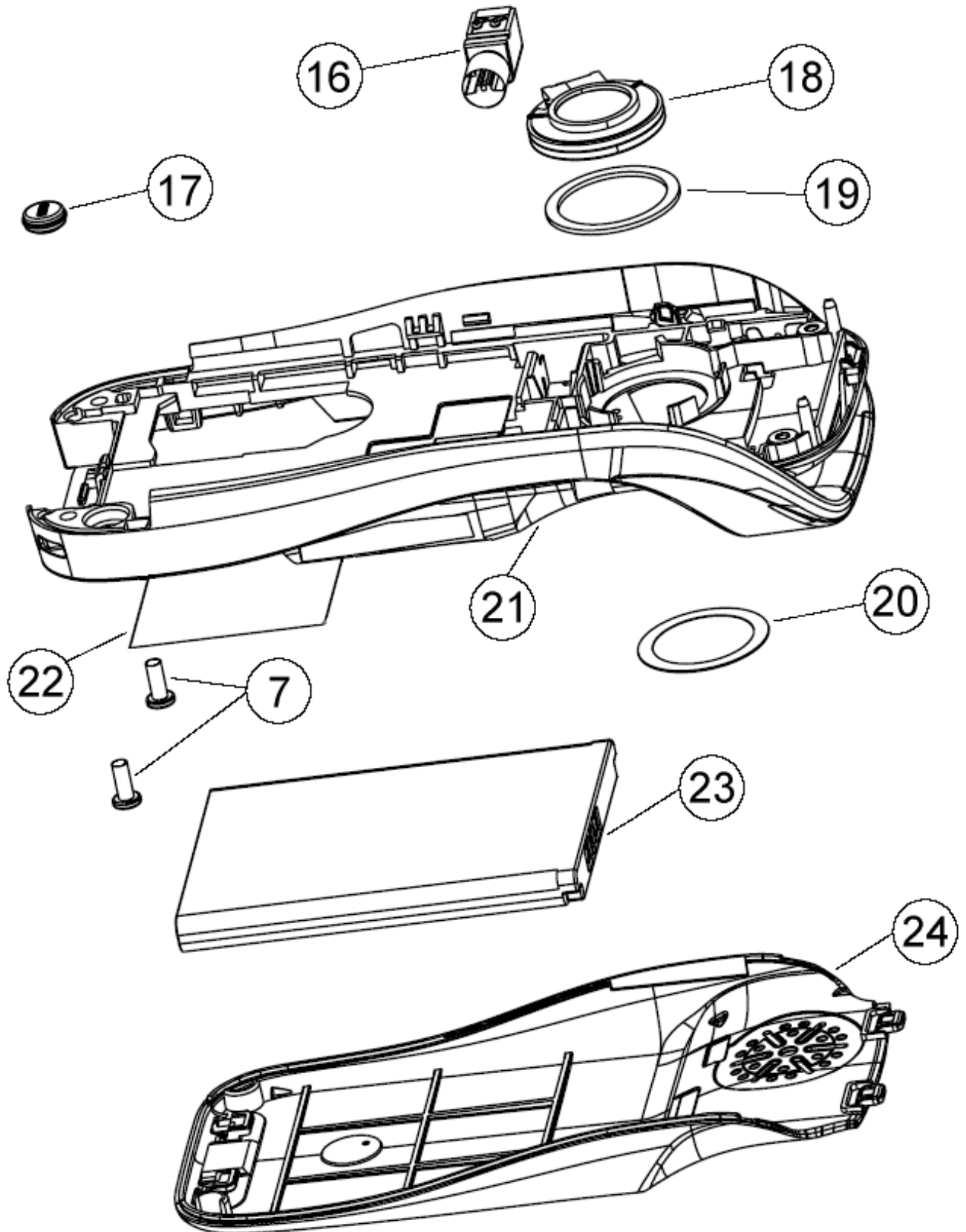



2 Part List

2.1 Part list phone

This Part List includes all parts possible to replace by using the Mechanical Repair Process. Parts available to order will be found in the Web Shop. Pos. number refers to the Exploded View.

Pos.	Description	Part Number	Comments
1	LABEL CO-BRAND STD	ODM80-10200	
1	LABEL CO-BRAND ORANGE	ODM80-17050	
1	LABEL CO-BRAND FIDO	ODM80-16449	
1	LABEL CO-BRAND VIRGIN	ODM80-10710	
1	LABEL CO-BRAND TELEFONNICA MOVISTAR	ODM80-10650	
1	LABEL CO-BRAND AMENA	ODM80-10560	
1	LABEL CO-BRAND T-MOBILE	ODM80-10490	
1	LABEL CO-BRAND TIM	ODM80-10460	
1	LABEL CO-BRAND CMCC	ODM80-10340	
1	LABEL CO-BRAND VODAFONE	ODM80-10310	
1	LABEL CO-BRAND O2	ODM80-10250	
1	LABEL CO-BRAND SFR	ODM80-10823	
2	Bottom cover	ODM53-68900	
3	Front Cover assembly (A-cover) plucky pink	ODM53-84802	
3	Front Cover assembly (A-cover) midnight gray	ODM53-84172	
3	Front Cover assembly (A-cover) sensitive white	ODM53-84050	
4	KEYPAD ASSY LATIN	ODM65-40070	
4	KEYPAD ASSY ARABIC	ODM65-40824	
4	KEYPAD ASSY BOPOMOFO	ODM65-40916	
4	KEYPAD ASSY CHINESE	ODM65-40792	
4	KEYPAD ASSY CYRILLIC	ODM65-40171	
4	KEYPAD ASSY HEBREW	ODM65-40384	
4	KEYPAD ASSY THAI	ODM65-40555	
5	Joystick plastic cap	ODM53-76744	
6	Joystick dust gasket	ODM57-29405	
7	Screw	ODM51-64008	
8	Metal frame assembly	ODM52-74230	
9	RECEIVER HOLDER	ODM53-49273	
10	Receiver	ODM42-60360	
11	RECEIVER GASKET	ODM57-40083	
12	Dome sheet	ODM65-68354	
13	Display module	ODM37-80401	
14	Shield can lid BB	ODM52-50783	
15	Shield can lid RF	ODM52-52774	
16	Vibrator	ODM40-72100	
17	Microphone	ODM43-90210	
18	Speaker	ODM42-41032	
19	Speaker gasket	ODM57-95824	
20	Speaker dust mesh	ODM53-40783	
21	Frame (B-cover) assembly 850/1800	ODM650-50071092	



Pos.	Description	Part Number	Comments
21	Frame (B-cover) assembly 900/1800	ODM650-50071028	
22	TYPE Label STD	ODM80-94872	
22	TYPE Label Chinese	ODM80-72890	
23	Water indicator	ODM58-34982	
24	Battery cover assembly plucky pink	ODM53-86076	
24	Battery cover assembly midnight gray	ODM53-86472	
24	Battery cover assembly sensitive white	ODM53-86538	

3 Label Part List

Pos.	Description	Part Number	Comments
22	KRH Label	ODM80-94872	
	Printer Ribbon	LZK 102 734/1	

4 Revision History

Rev.	Date	Changes / Comments
A	2005-05-24	Initial release