

Confidential
Approved according to 00021-LXE 107 42/1

SCHEMA
DIAGRAM

Sony Ericsson		Uppgård (även faktaansvarig om annan) - Prepared (also subject responsible if other)	
Toleranser - Tolerances BASEBAND Tillhör - Made for		RT/SEMC/BGRRHP Christian Lindqvist Dokumentansvarig/Godkänd - Document responsible/Approved	
Logic Top		Datum - Date 3/6/2007	
Ritningsregler - Drawing rules		Produktbenämning - Product name SCHEMATIC	
2/1911-ROA 128 2290 Uen		Rev D	
AcePlus		Blad - Sheet 01 of 21	

LZF 030 102/F RB

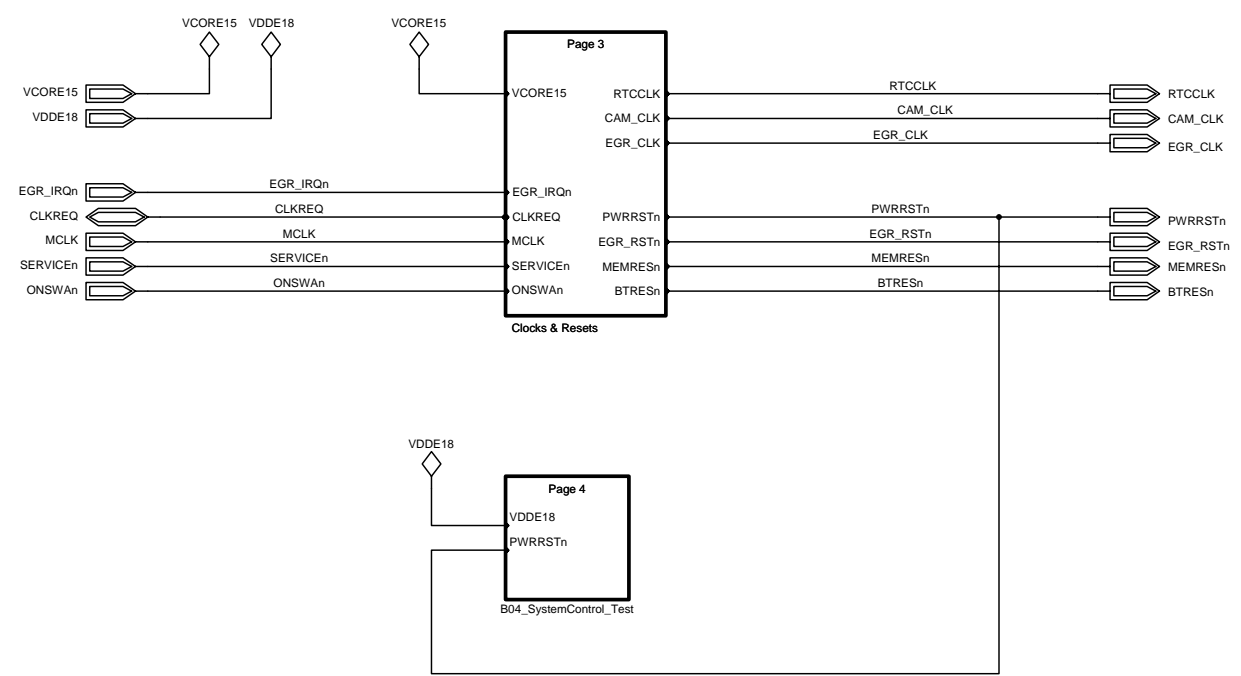

Confidential
Approved according to 00021-LXE 107 42/1 SCHEMA DIAGRAM

Sony Ericsson		Uppgord (oven faktaansvarig om annan) - Prepared (also subject responsible if other)	
BASEBAND		RT/SEMC/BGRRHP Christian Lindqvist	
Toleranser - Tolerances	RT/SEMC/BGRRHD Norbert Ingram	Datum - Date	Rev
Tilhan - Made for	System Control Top	3/6/2007	D
Ritningsregler - Drawing rules		Produktbenämning - Product name	
2/1911-ROA 128 2290 Uen		SCHEMATIC	
Blad - Sheet			
02 of 21			

1 2 3 4 5 6 7 8 9 10 11

A B C D E F G H

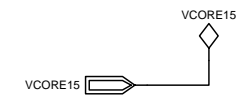
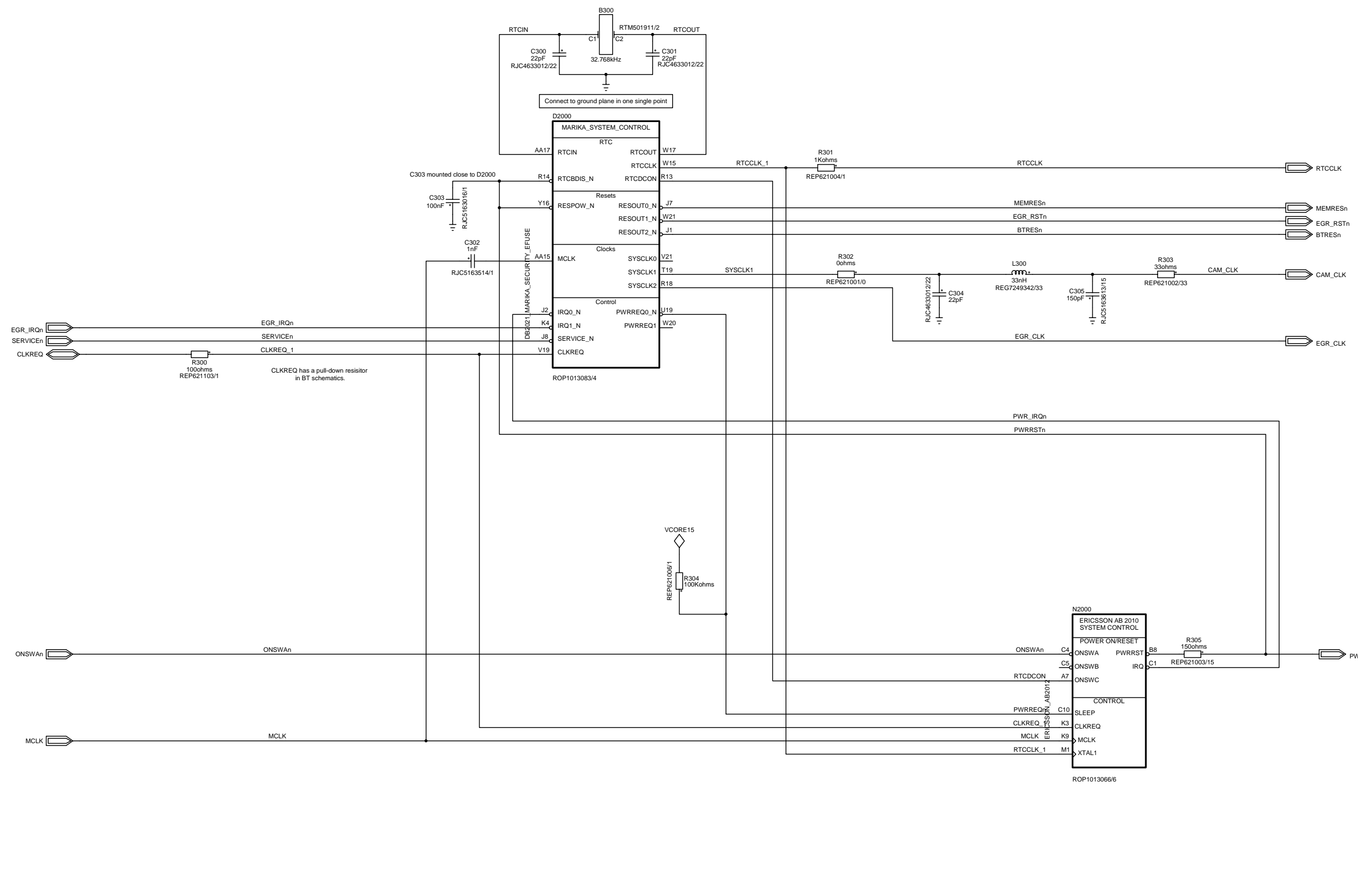

Confidential
Approved according to 00021-LXE 107 42/1

SCHEMA
DIAGRAM

Sony Ericsson		Uppgord (oven faktaansvarig om annan) - Prepared (also subject responsible if other)	
Toleranser - Tolerances BASEBAND Tillhor - Made for System Control Clocks & Resets		RT/SEMC/BGRRHP Christian Lindqvist Dokumentansvarig/Godkand - Document responsible/Approved RT/SEMC/BGRRHD Norbert Ingram Datum - Date 3/6/2007 Rev D	
Ritningsregler - Drawing rules		Produktbenamning - Product name SCHEMATIC Dokumentnr - Document nr 2/1911-ROA 128 2290 Uen Bladd - Sheet 03 of 21	

AcePlus

1 2 3 4 5 6 7 8 9 10 11

LZF 030 102/F RB

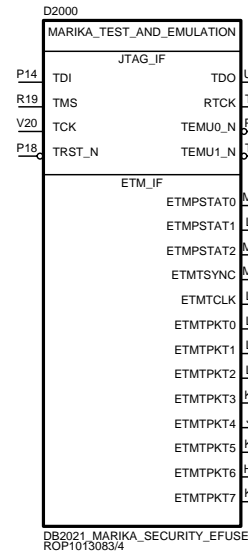
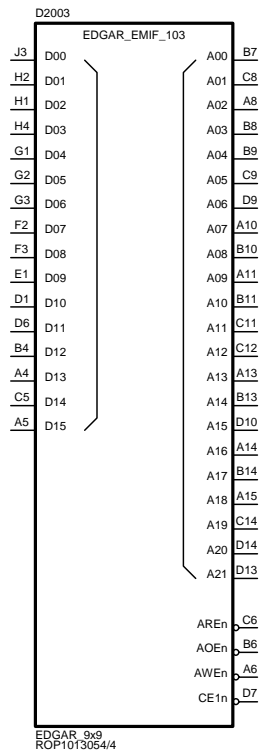
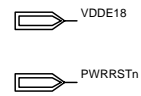

Confidential
 Approved according to 00021-LXE 107 42/1 SCHEMA DIAGRAM

Sony Ericsson	Uppgjord (även faktaansvarig om annan) - Prepared (also subject responsible if other)	
RT/SEMC/BGRRHP Christian Lindqvist	Dokumentansvarig/Godkänd - Document responsible/Approved	Datum - Date
RT/SEMC/BGRRHD Norbert Ingram	3/6/2007	Rev D
BASEBAND	Produktbenämning - Product name	
System Control Test	SCHEMATIC	
Ritningsregler - Drawing rules	Dokumentnr - Document nr	Blad - Sheet
	2/1911-ROA 128 2290 Uen	04 of 21

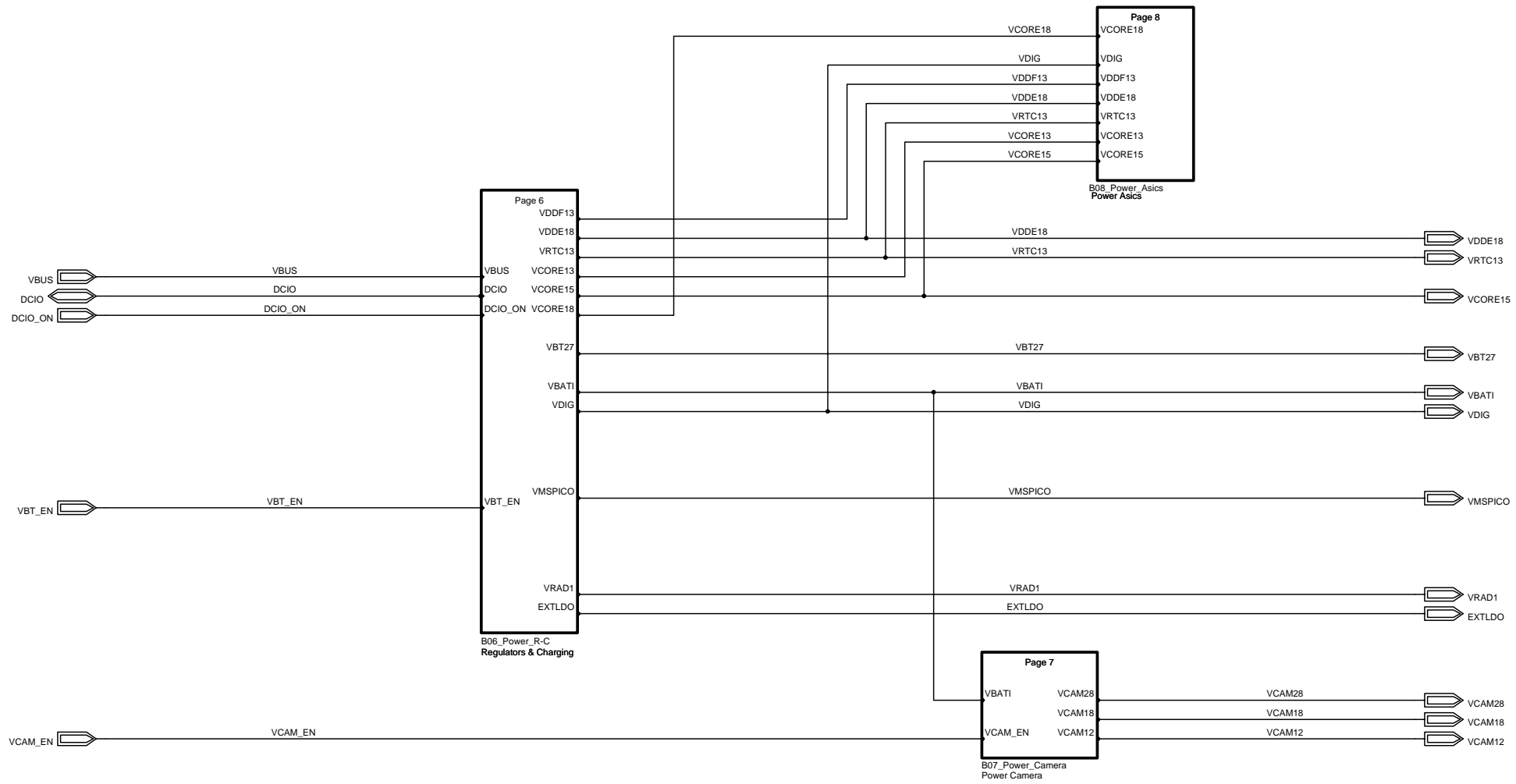

Confidential
 Approved according to 00021-LXE 107 42/1 SCHEMA DIAGRAM

Sony Ericsson		Uppgord (oven faktaansvarig om annan) - Prepared (also subject responsible if other)	
Toleranser - Tolerances BASEBAND Tillhan - Made for Power Top Ritningsregler - Drawing rules		RT/SEMC/BGRRHP Christian Lindqvist Dokumentansvarig/Godkand - Document responsible/Approved RT/SEMC/BGRRHD Norbert Ingram	Datum - Date 3/6/2007 Rev D
		Produktbenamning - Product name SCHEMATIC	
		Dokumentnr - Document nr 2/1911-ROA 128 2290 Uen	Blad - Sheet 05 of 21

LZF 030 102/F RB

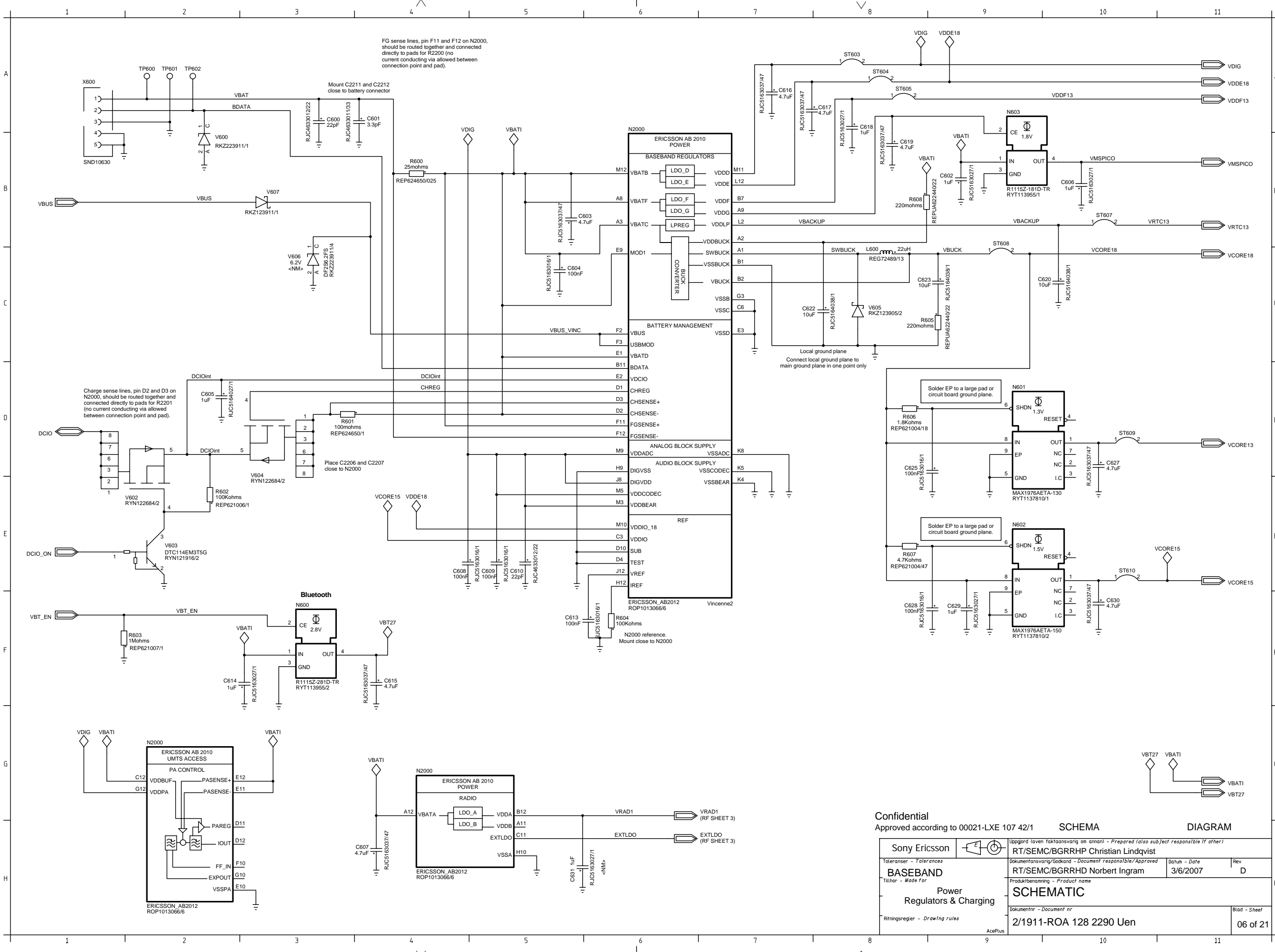

FG sense lines, pin F11 and F12 on N2000, should be routed together and connected directly to pads for R2200 (no current conducting via allowed between connection point and pad).

Charge sense lines, pin D2 and D3 on N2000, should be routed together and connected directly to pads for R2201 (no current conducting via allowed between connection point and pad).

Local ground plane
Connect local ground plane to main ground plane in one point only

Confidential
Approved according to 00021-LXE 107 42/1

SCHEMA

DIAGRAM

Sony Ericsson		Uppgård (oven faktaansvarig om annan) - Prepared (also subject responsible if other)	
Toleranser - Tolerances BASEBAND		RT/SEMC/BGRRHP Christian Lindqvist	
Tillhän - Made for Power Regulators & Charging		Dokumentansvarig/Godkänd - Document responsible/Approved RT/SEMC/BGRRHD Norbert Ingram	Datum - Date 3/6/2007
Ritningsregler - Drawing rules		Produktbenämning - Product name SCHEMATIC	
AcePlus		Dokumentnr - Document nr 2/1911-ROA 128 2290 Uen	
			Blad - Sheet 06 of 21

LZF 030 102/F RB

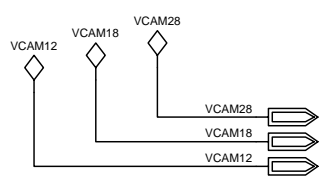
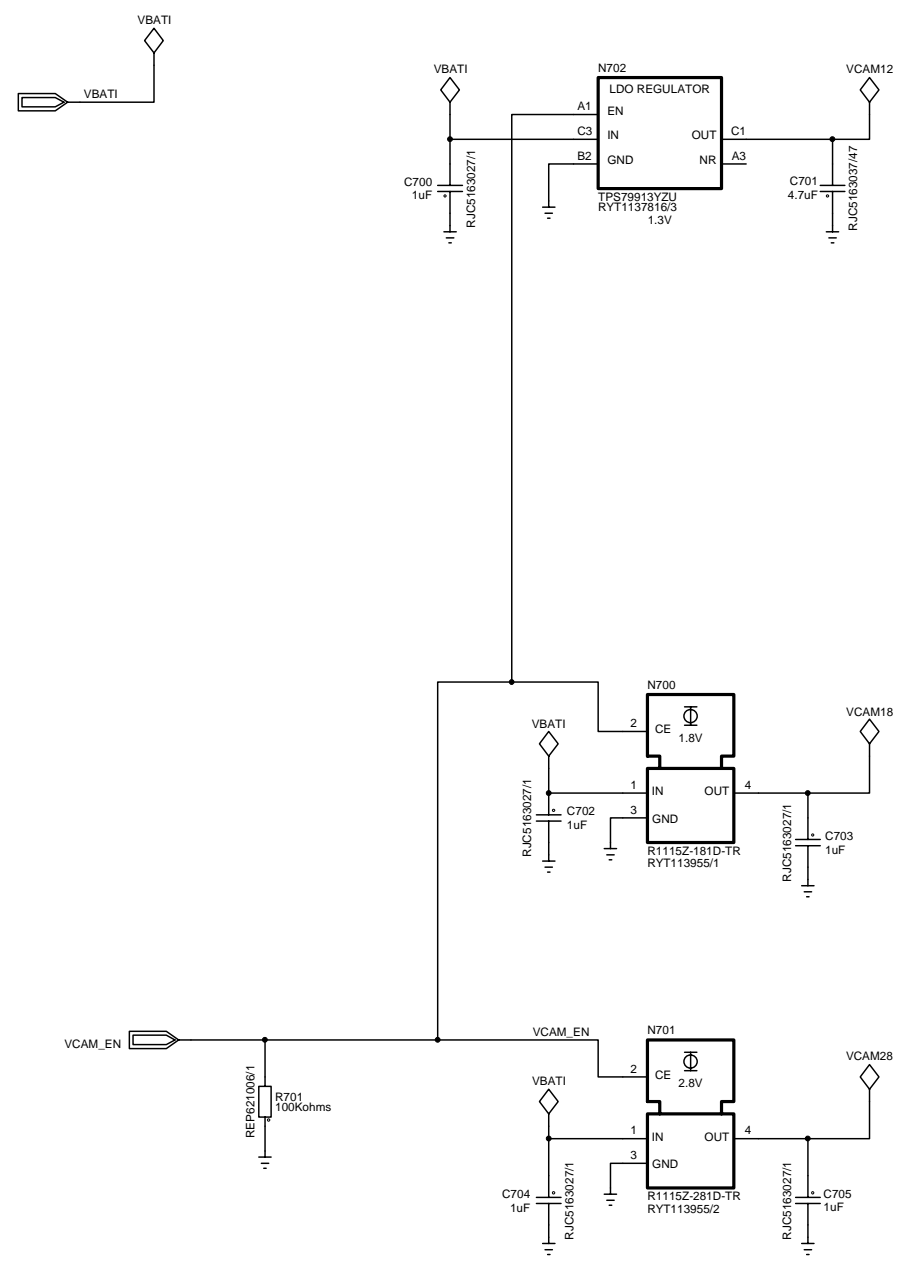

Confidential
 Approved according to 00021-LXE 107 42/1 SCHEMA DIAGRAM

Sony Ericsson 		Uppgord (oven faktaansvarig om annan) - Prepared (also subject responsible if other)	
BASEBAND Tillhor - Made for Power Camera		RT/SEMC/BGRRHP Christian Lindqvist Dokumentansvarig/Godkand - Document responsible/Approved	Datum - Date 3/6/2007
Ritningsregler - Drawing rules		Produktbenamning - Product name SCHEMATIC	
2/1911-ROA 128 2290 Uen			Blad - Sheet 07 of 21

LZF 030 102/F RB

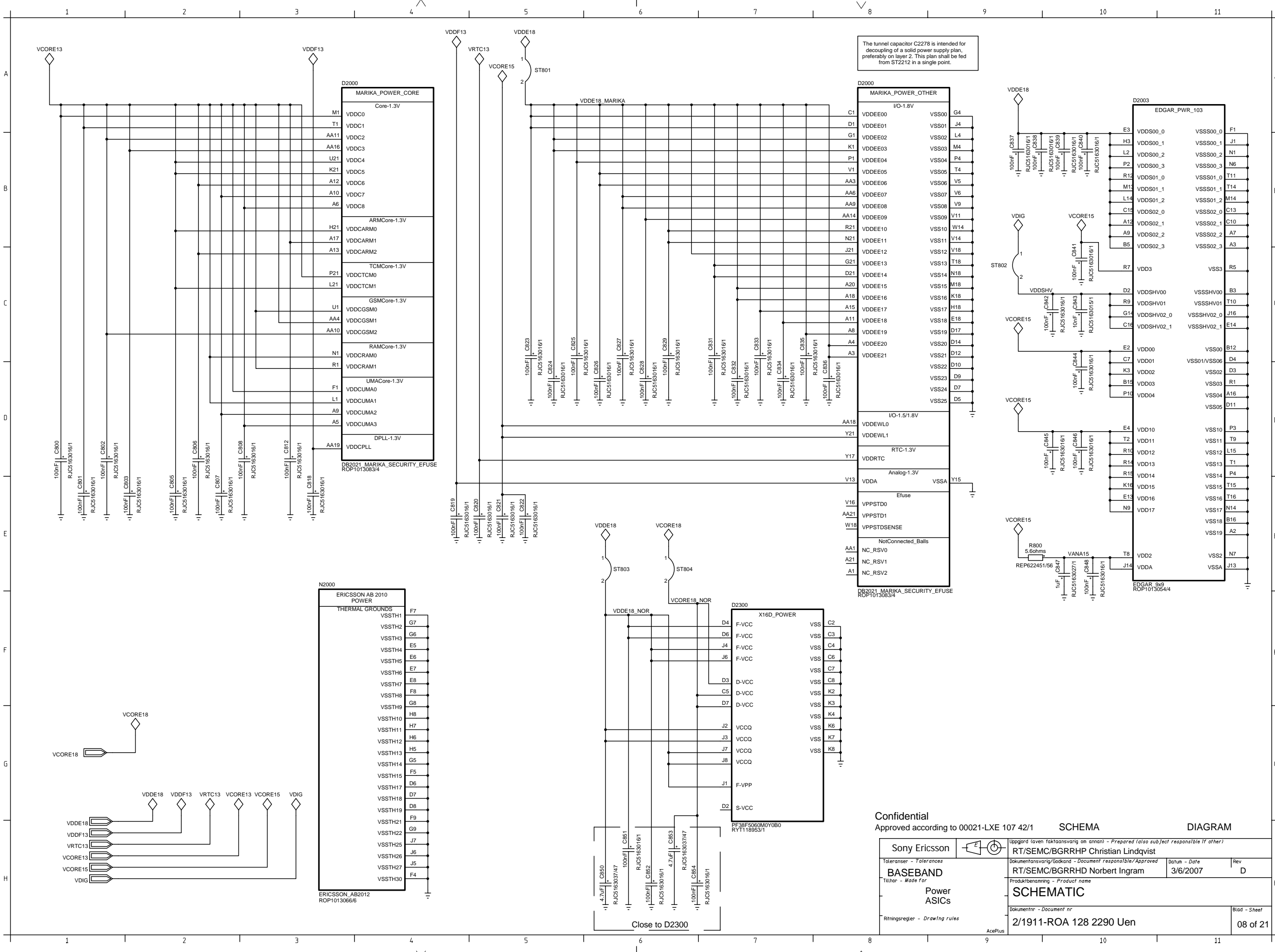

Confidential
 Approved according to 00021-LXE 107 42/1

SCHEMA

DIAGRAM

Sony Ericsson

Uppgord (oven faktaansvarig om annan) - Prepared (also subject responsible if other)
 RT/SEMC/BGRRHP Christian Lindqvist

Dokumentansvarig/Godkand - Document responsible/Approved
 RT/SEMC/BGRRHD Norbert Ingram

Datum - Date
 3/6/2007

Rev
 D

Produktbenämning - Product name
SCHEMATIC

Dokumentnr - Document nr
 2/1911-ROA 128 2290 Uen

Blad - Sheet
 08 of 21

Toleranser - Tolerances
BASEBAND
 Tillhör - Made for
Power ASICS

Ritningsregler - Drawing rules

AcePlus

LZF 030 102/F RB

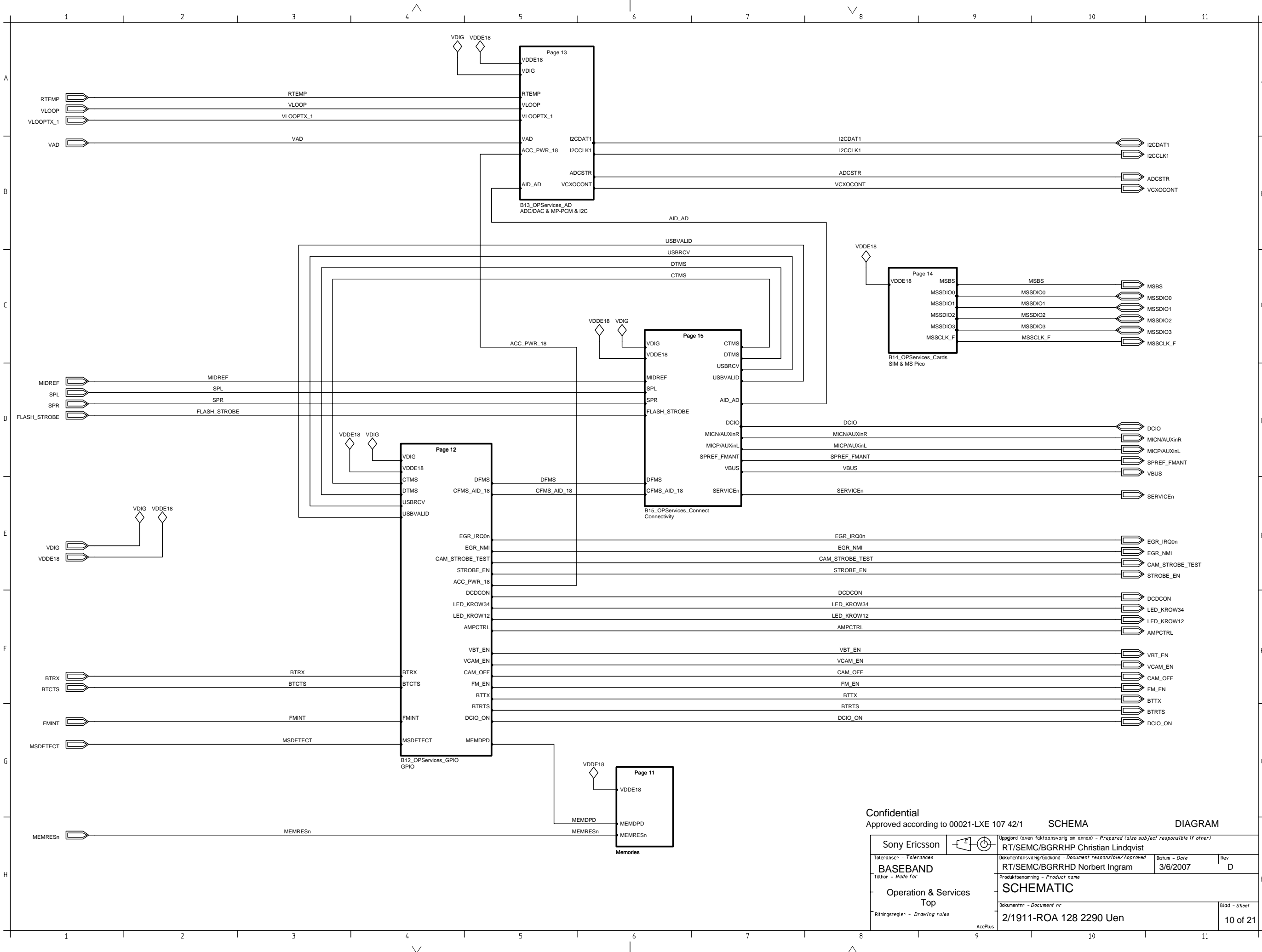

Confidential
 Approved according to 00021-LXE 107 42/1 SCHEMA DIAGRAM

Sony Ericsson		Uppgård (även faktaansvarig om annan) - Prepared (also subject responsible if other)	
Toleranser - Tolerances BASEBAND Tillhör - Made for		RT/SEMC/BGRRHP Christian Lindqvist	
Operation & Services Top		Dokumentansvarig/Godkänd - Document responsible/Approved RT/SEMC/BGRRHD Norbert Ingram	Datum - Date 3/6/2007
Ritningsregler - Drawing rules		Produktbenämning - Product name SCHEMATIC	
Dokumentnr - Document nr 2/1911-ROA 128 2290 Uen			Blad - Sheet 10 of 21

LZF 030 102/F RB

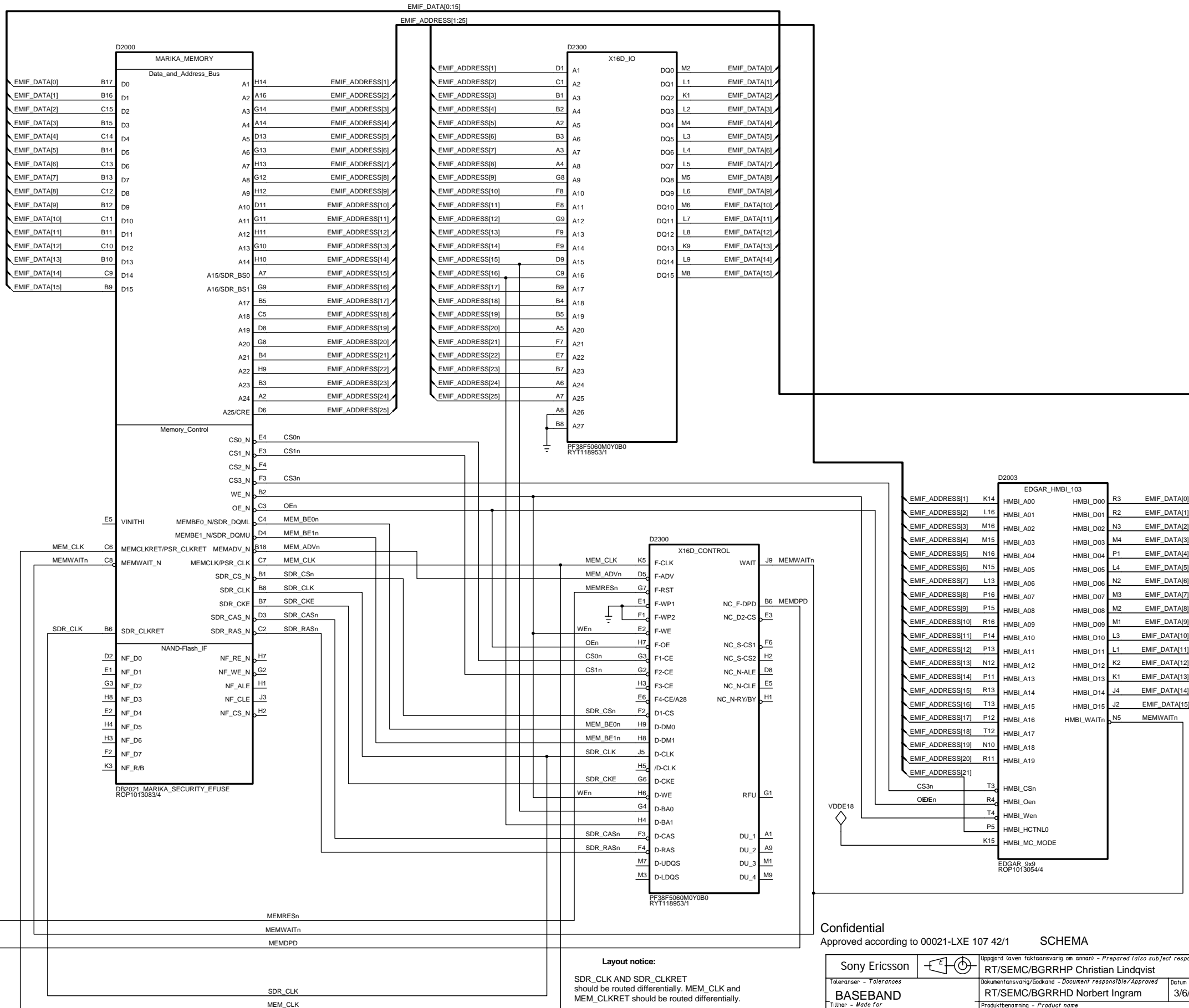

Layout notice:
 SDR_CLK AND SDR_CLKRET should be routed differentially. MEM_CLK and MEM_CLKRET should be routed differentially.

Confidential
 Approved according to 00021-LXE 107 42/1 SCHEMA DIAGRAM

Sony Ericsson Toleranser - Tolerances BASEBAND Tillver - Made for Operation & Services Memories Ritningsregler - Drawing rules		Uppgord (aven faktaansvarig om annan) - Prepared (also subject responsible if other) RT/SEMC/BGRRHP Christian Lindqvist Dokumentansvarig/Godkand - Document responsible/Approved RT/SEMC/BGRRHD Norbert Ingram Produktbenamning - Product name SCHEMATIC Dokumentnr - Document nr 2/1911-ROA 128 2290 Uen		Datum - Date 3/6/2007 Rev D Blad - Sheet 11 of 21
---	--	--	--	---

LZF 030 102/F RB

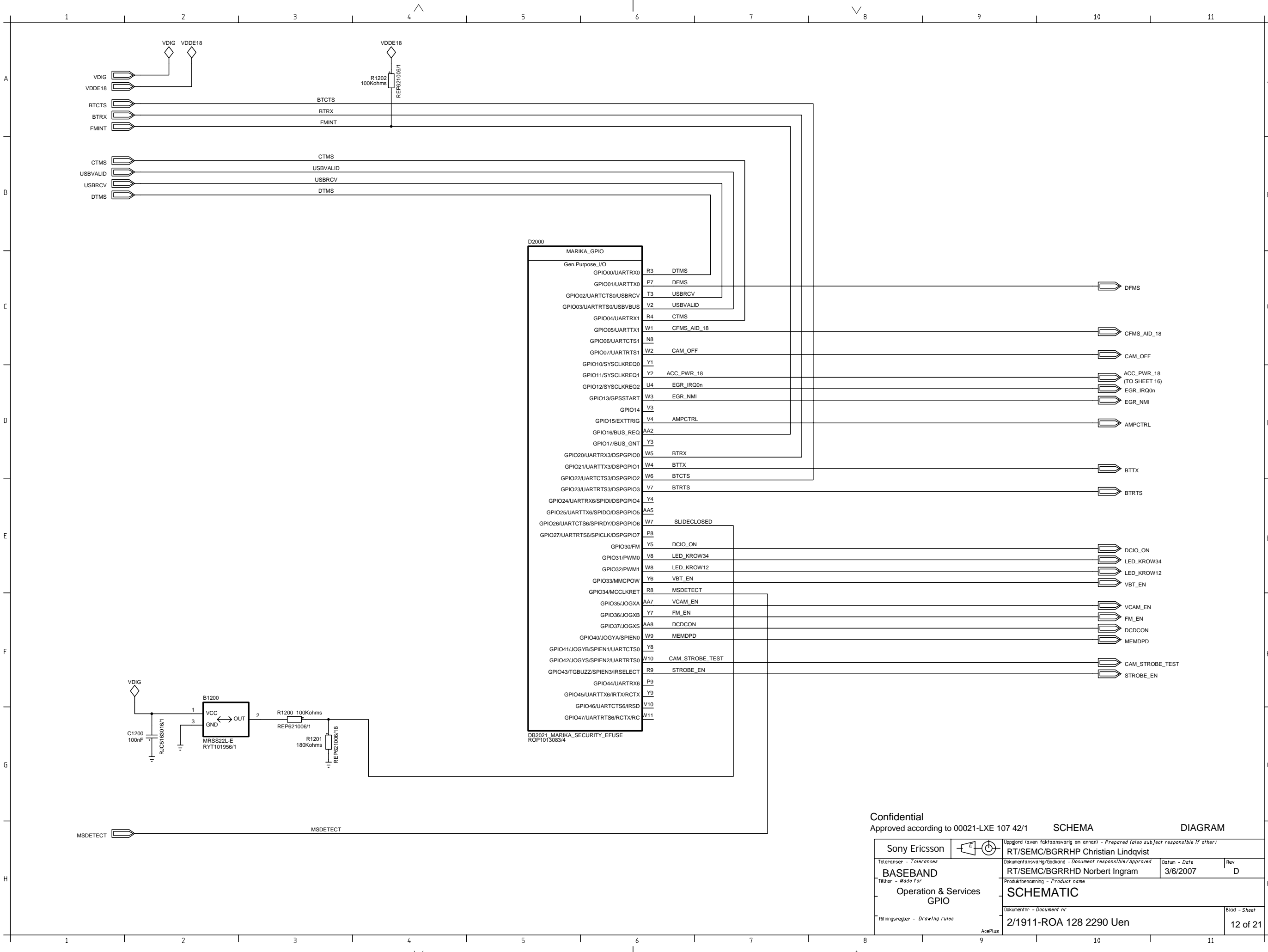

Confidential
 Approved according to 00021-LXE 107 42/1 SCHEMA DIAGRAM

Sony Ericsson		Uppgjord (även faktaansvarig om annan) - Prepared (also subject responsible if other)	
Toleranser - Tolerances BASEBAND		RT/SEMC/BGRRHP Christian Lindqvist	
Tillhör - Made for Operation & Services GPIO		Dokumentansvarig/Godkänd - Document responsible/Approved RT/SEMC/BGRRHD Norbert Ingram	Datum - Date 3/6/2007
Ritningsregler - Drawing rules		Produktbenämning - Product name SCHEMATIC	
Dokumentnr - Document nr 2/1911-ROA 128 2290 Uen			Blad - Sheet 12 of 21

LZF 030 102/F RB

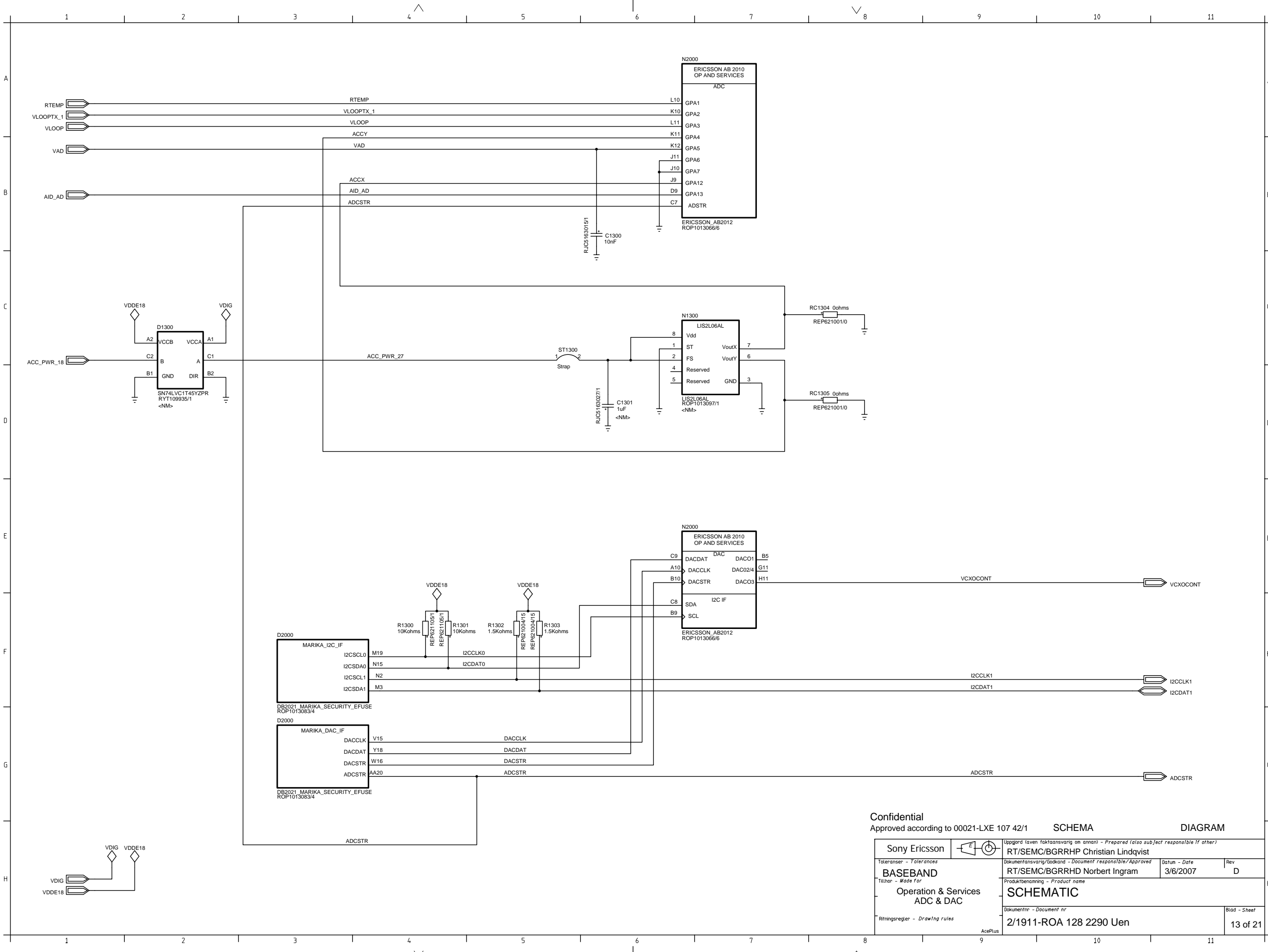

Confidential
Approved according to 00021-LXE 107 42/1 SCHEMA DIAGRAM

Sony Ericsson		Uppgord (oven faktaansvarig om annan) - Prepared (also subject responsible if other)	
Toleranser - Tolerances BASEBAND		RT/SEMC/BGRRHP Christian Lindqvist	
Tillhän - Made for Operation & Services ADC & DAC		Dokumentansvarig/Godkänd - Document responsible/Approved RT/SEMC/BGRRHD Norbert Ingram	Datum - Date 3/6/2007
Ritningsregler - Drawing rules		Produktbenämning - Product name SCHEMATIC	
Dokumentnr - Document nr 2/1911-ROA 128 2290 Uen			Blad - Sheet 13 of 21

LZF 030 102/F RB

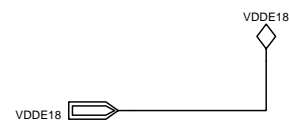
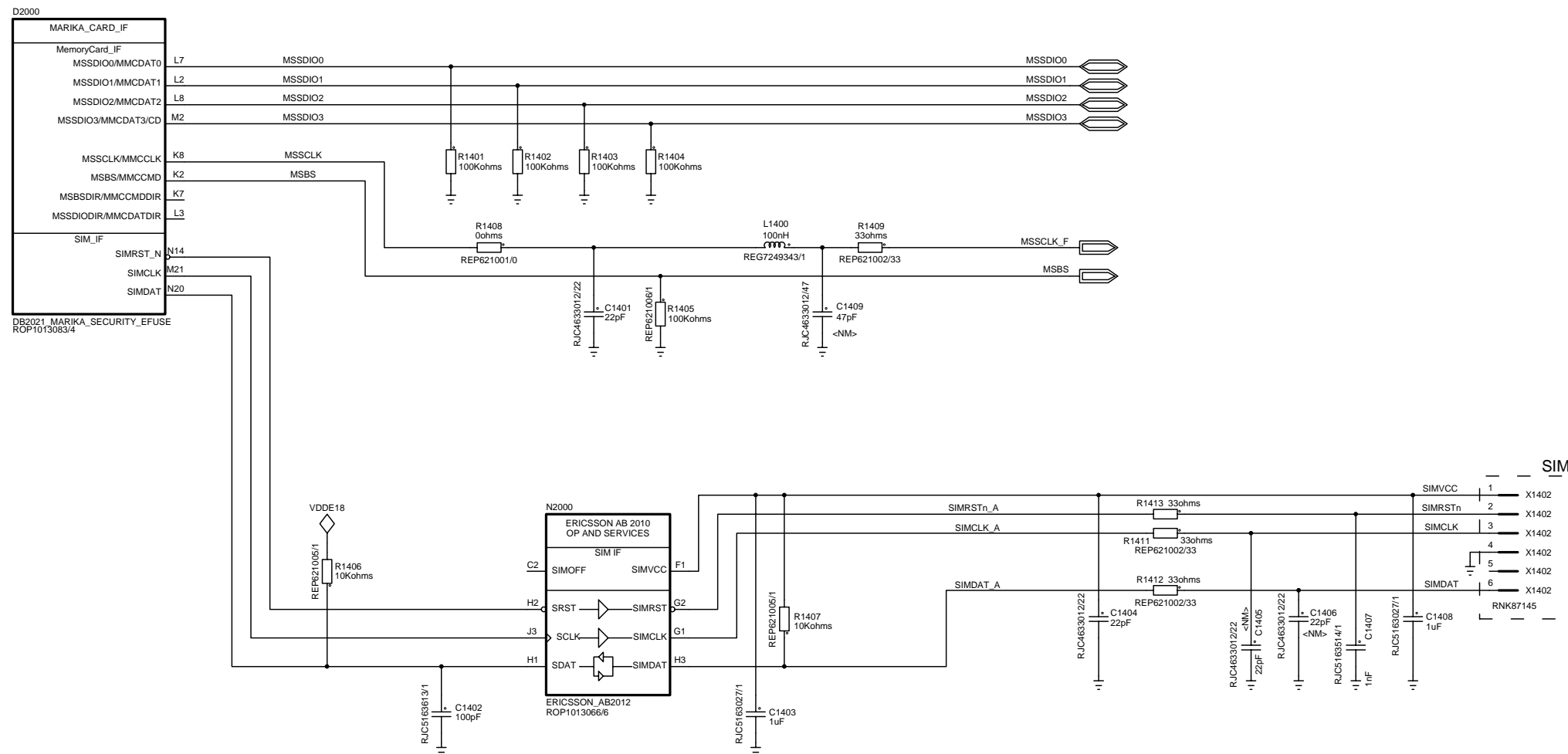

Confidential
Approved according to 00021-LXE 107 42/1 SCHEMA DIAGRAM

Sony Ericsson		Uppgord (oven faktaansvarig om annan) - Prepared (also subject responsible if other)	
Toleranser - Tolerances BASEBAND		RT/SEMC/BGRRHP Christian Lindqvist	
Tillhän - Made for Operation & Services M2 and SIM		Dokumentansvarig/Godkänd - Document responsible/Approved RT/SEMC/BGRRHD Norbert Ingram	Datum - Date 3/6/2007
Ritningsregler - Drawing rules		Produktbenämning - Product name SCHEMATIC	
Dokumentnr - Document nr 2/1911-ROA 128 2290 Uen			Blad - Sheet 14 of 21

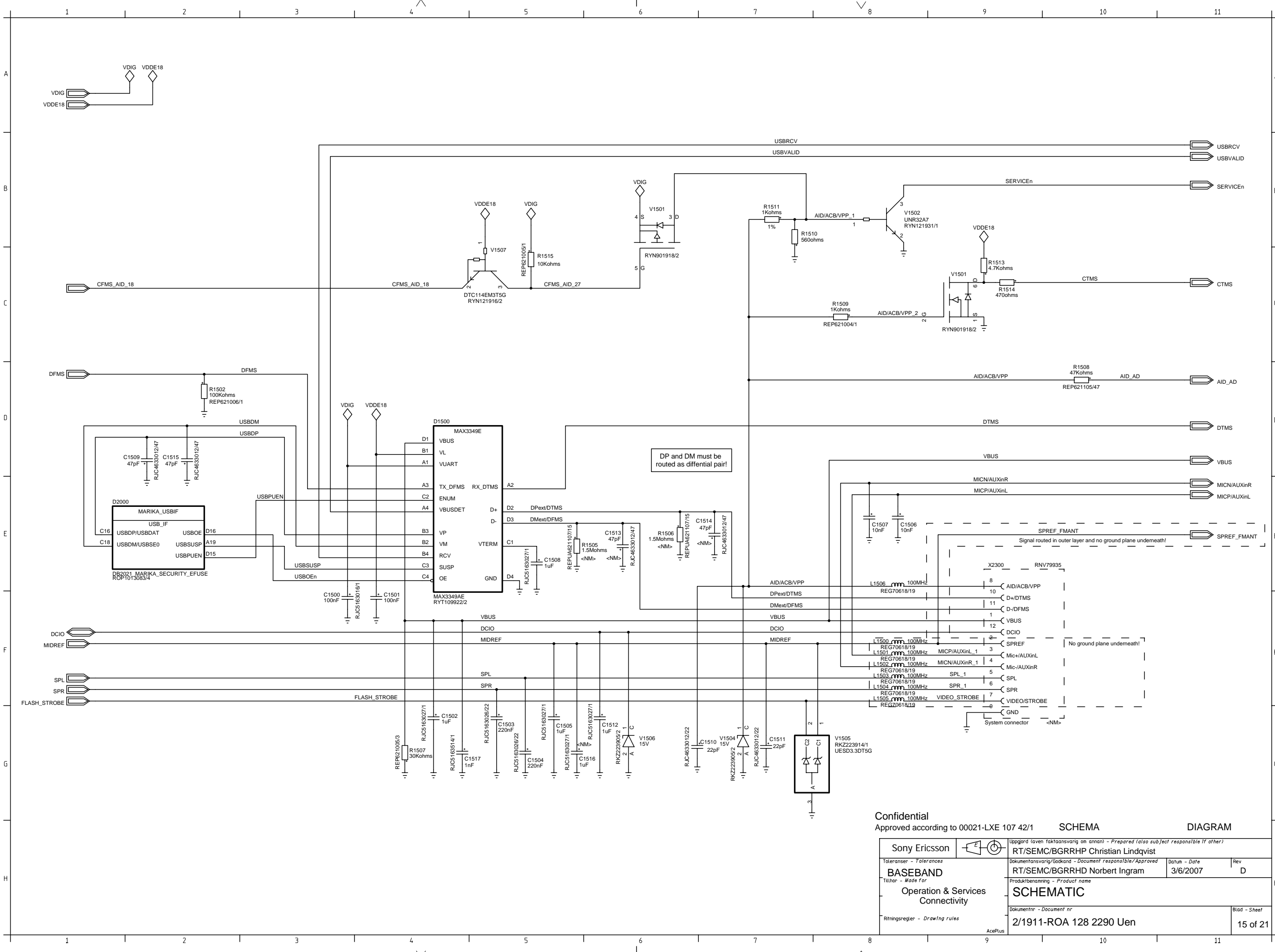

Confidential
Approved according to 00021-LXE 107 42/1 SCHEMA DIAGRAM

Sony Ericsson Toleranser - Tolerances BASEBAND Tillh�n - Made for Operation & Services Connectivity Ritningsregler - Drawing rules		Uppgord (oven faktaansvarig om annan) - Prepared (also subject responsible if other) RT/SEMC/BGRRHP Christian Lindqvist Dokumentansvarig/Godkand - Document responsible/Approved RT/SEMC/BGRRHD Norbert Ingram Produktbenamning - Product name SCHEMATIC Dokumentnr - Document nr 2/1911-ROA 128 2290 Uen		Datum - Date 3/6/2007 Rev D
			Blad - Sheet 15 of 21	

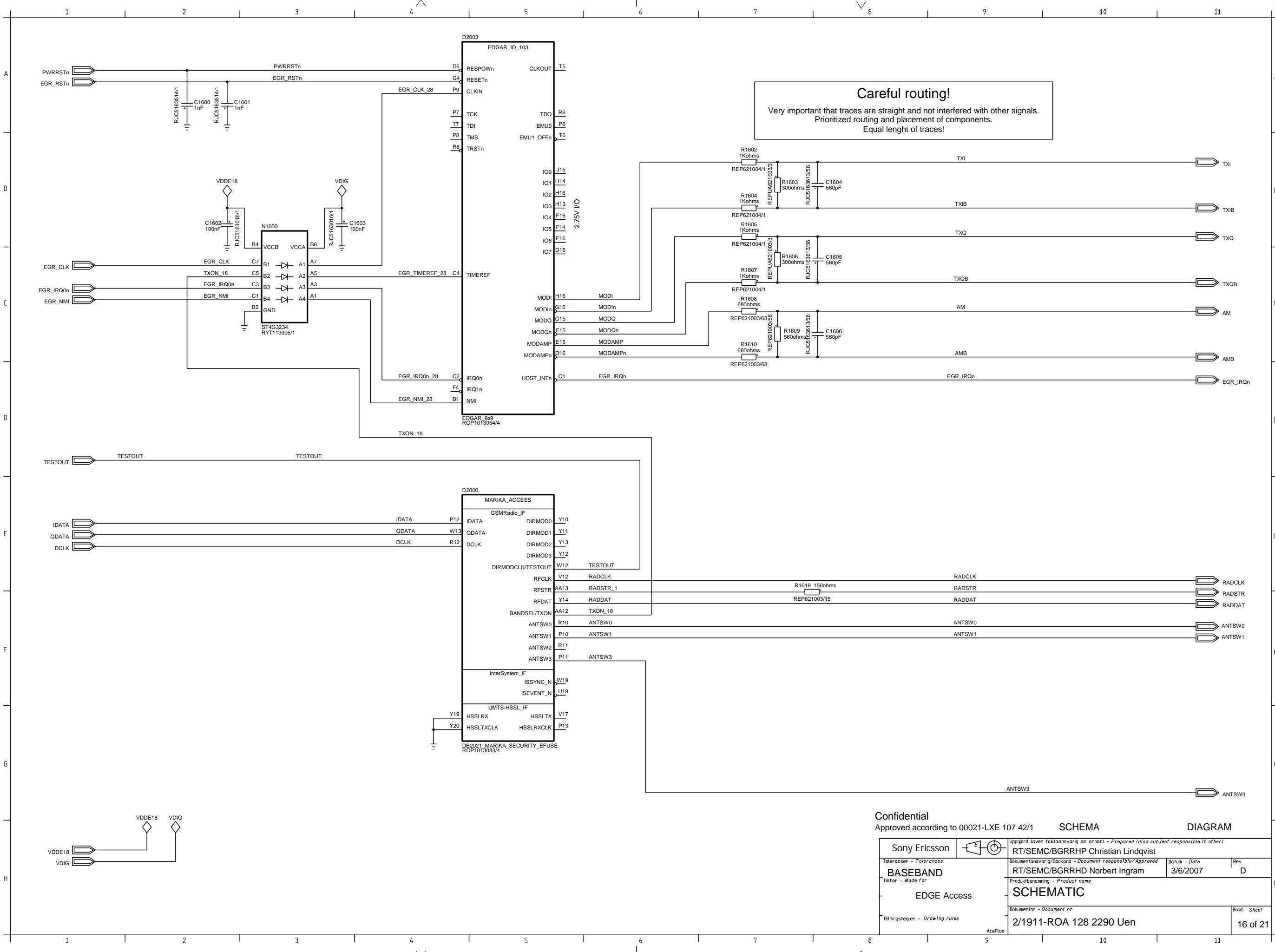

Careful routing!
 Very important that traces are straight and not interfered with other signals.
 Prioritized routing and placement of components.
 Equal length of traces!

Confidential
 Approved according to 00021-LXE 107 42/1

SCHEMA
 DIAGRAM

Sony Ericsson	Uppgård (oven faktaansvarig om annan) - Prepared (also subject responsible if other)	
Toleranser - Tolerances	RT/SEMC/BGRRHP Christian Lindqvist	Dokumentansvarig/Godkänd - Document responsible/Approved
BASEBAND	RT/SEMC/BGRRHD Norbert Ingram	Datum - Date
Tillhör - Made for	EDGE Access	3/6/2007
	Rev	D
	Produktbenämning - Product name	
	SCHEMATIC	
	Dokumentnr - Document nr	
	2/1911-ROA 128 2290 Uen	
	Blad - Sheet	
	16 of 21	

ACEPlus

LZF 030 102/F RB

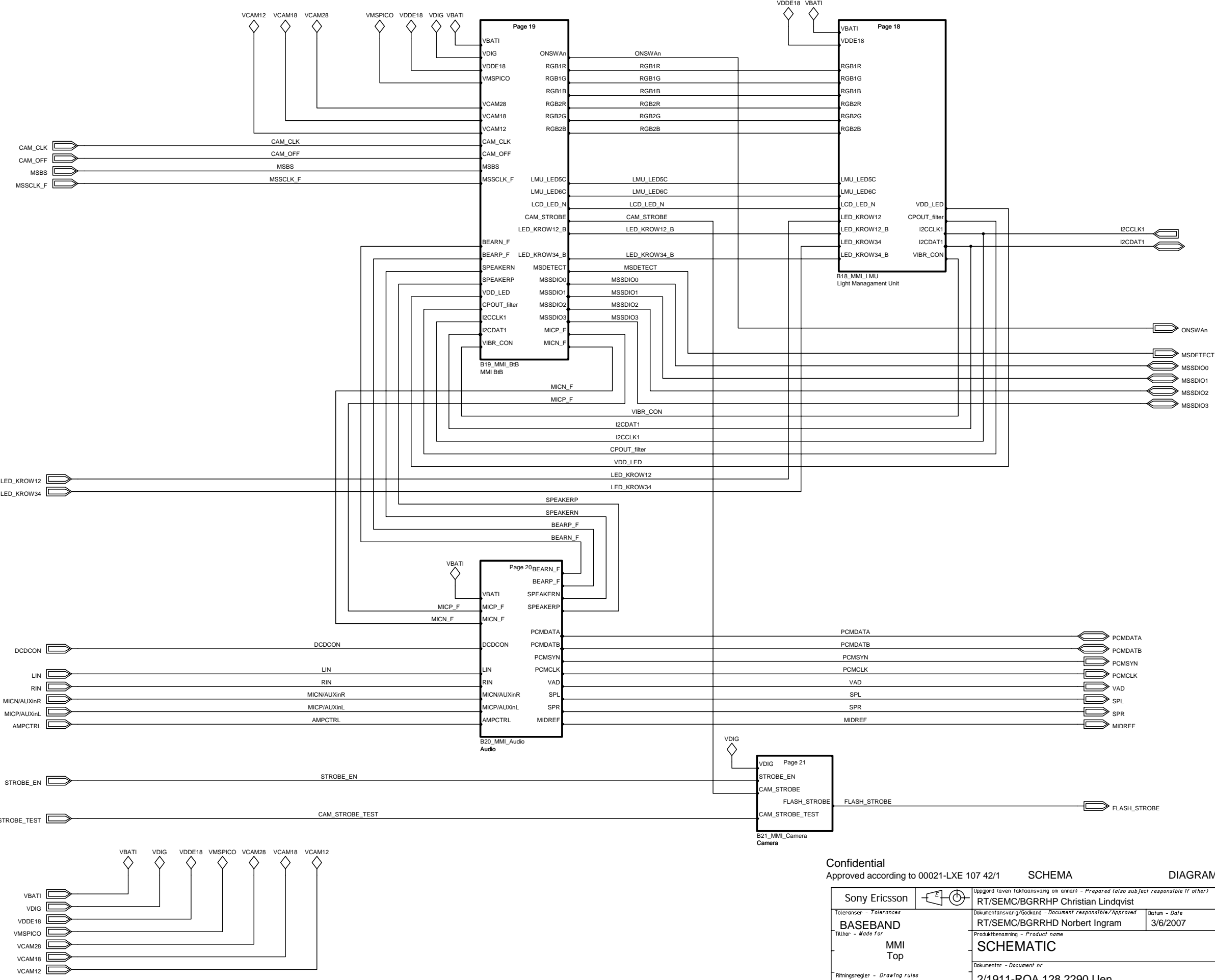

Confidential
Approved according to 00021-LXE 107 42/1

SCHEMA **DIAGRAM**

Uppgord (aven faktaansvarig om annan) - Prepared (also subject responsible if other) RT/SEMC/BGRRHP Christian Lindqvist		Dokumentansvarig/Godkand - Document responsible/Approved RT/SEMC/BGRRHD Norbert Ingram		Datum - Date 3/6/2007		Rev D	
Toleranser - Tolerances BASEBAND Tillhän - Made for MMI Top				Produktbenämning - Product name SCHEMATIC			
Ritningsregler - Drawing rules 2/1911-ROA 128 2290 Uen						Blad - Sheet 17 of 21	

AcePlus

LZF 030 102/F RB

I2C address
80h Write commands
81h Read commands

Revision address
ASIC1 37h (response c9h)
ASIC 38h (response 50h)

Mount R1802, C1810, L1800,
V1800 and V1801 close together

same groundpoint for
C1808, C1810, V1800

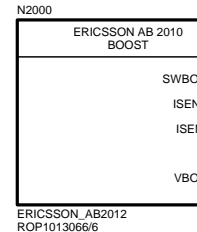
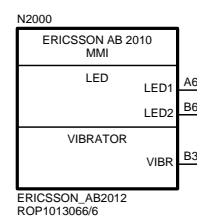
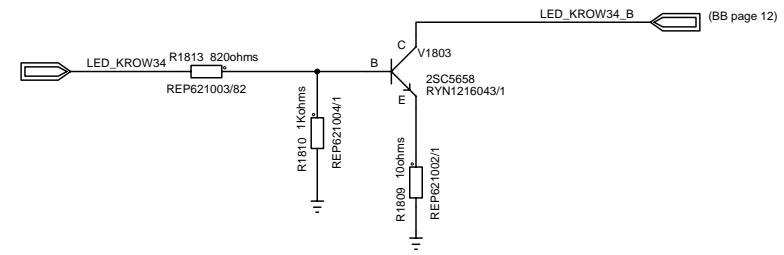
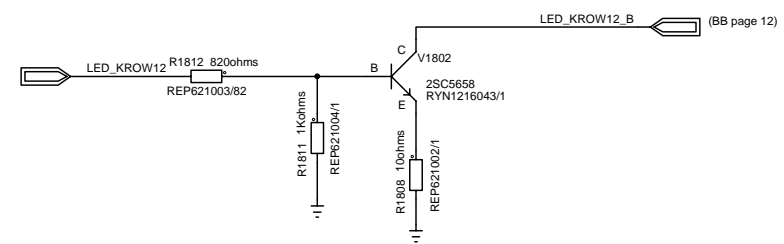
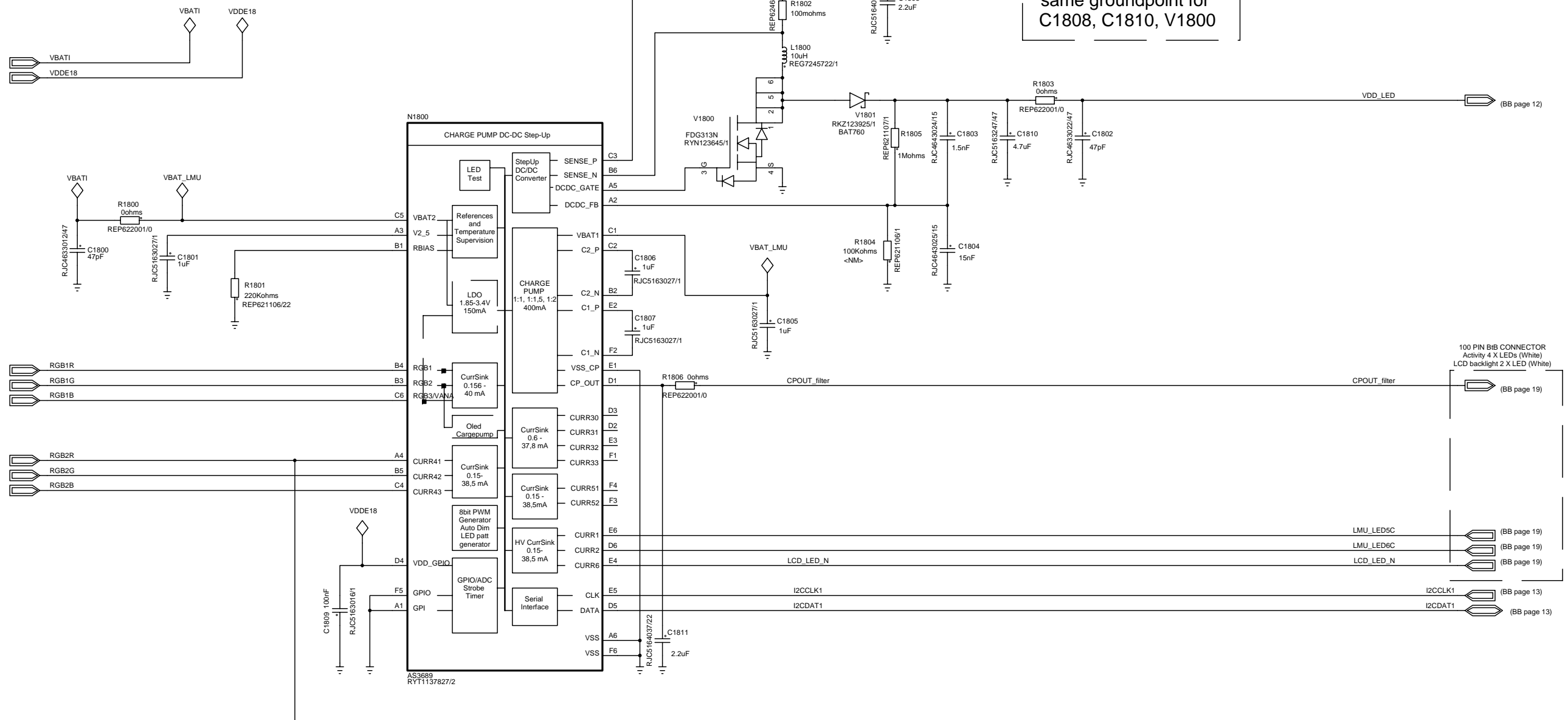

Confidential
Approved according to 00021-LXE 107 42/1 SCHEMA DIAGRAM

Sony Ericsson		Uppgård (oven faktaansvarig om annan) - Prepared (also subject responsible if other)	
BASEBAND		RT/SEMC/BGRRHP Christian Lindqvist	
Tillhör - Made for		RT/SEMC/BGRRHD Norbert Ingram	
LMU LIGHT MANAGEMENT UNIT		Produktbenämning - Product name	
Ritningsregler - Drawing rules		3/6/2007	
		Blad - Sheet	
		2/1911-ROA 128 2290 Uen	
		18 of 21	

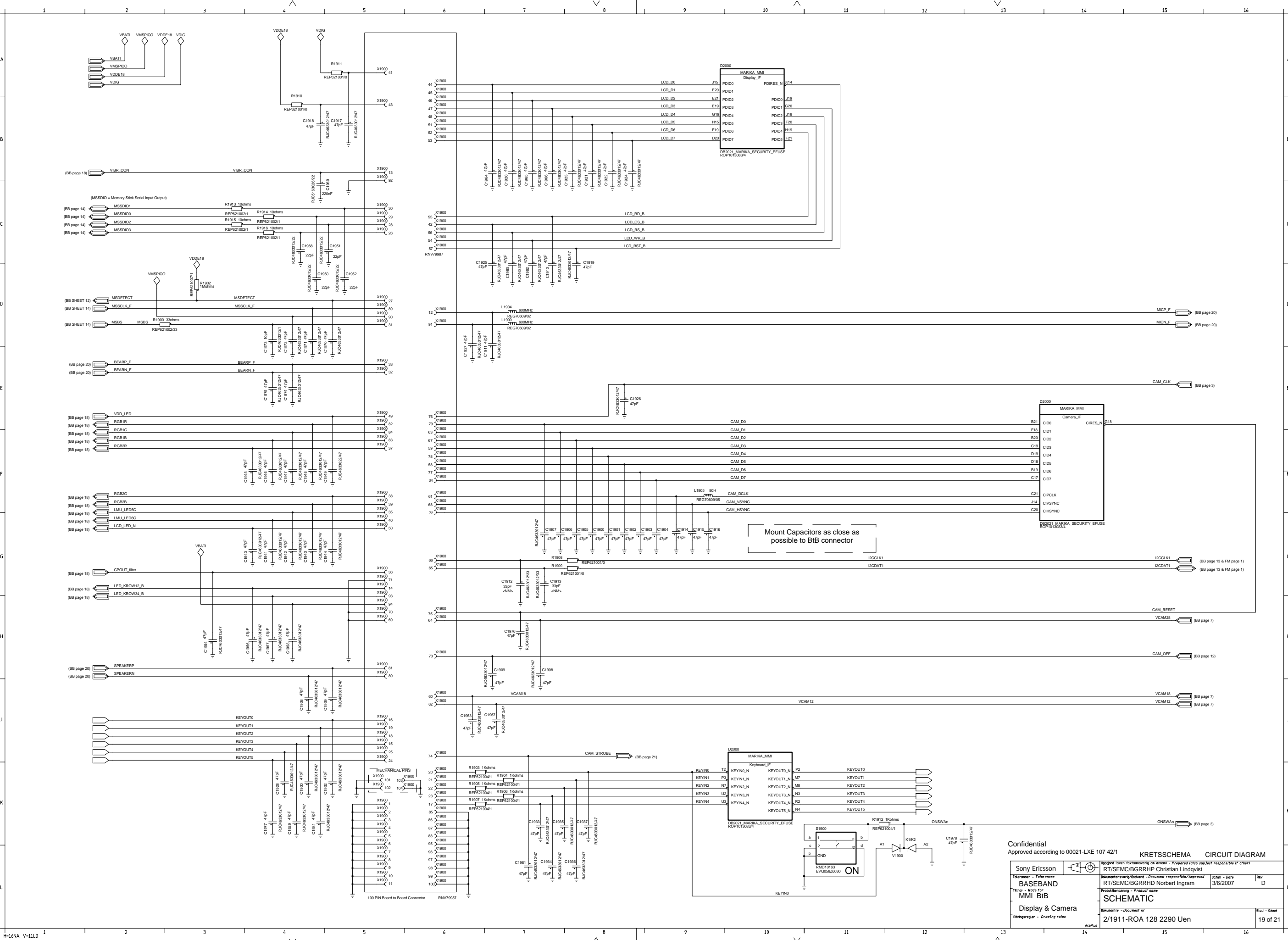

Confidential
Approved according to 00021-LXE 107 42/1

KRETSSCHEMA CIRCUIT DIAGRAM

Document nr: 2/1911-ROA 128 2290 Uen

Bas - Sheet: 19 of 21

Approved according to 00021-LXE 107 42/1

Document nr: 2/1911-ROA 128 2290 Uen

Bas - Sheet: 19 of 21

Document nr: 2/1911-ROA 128 2290 Uen

Bas - Sheet: 19 of 21

LZF 030 101/F RB1

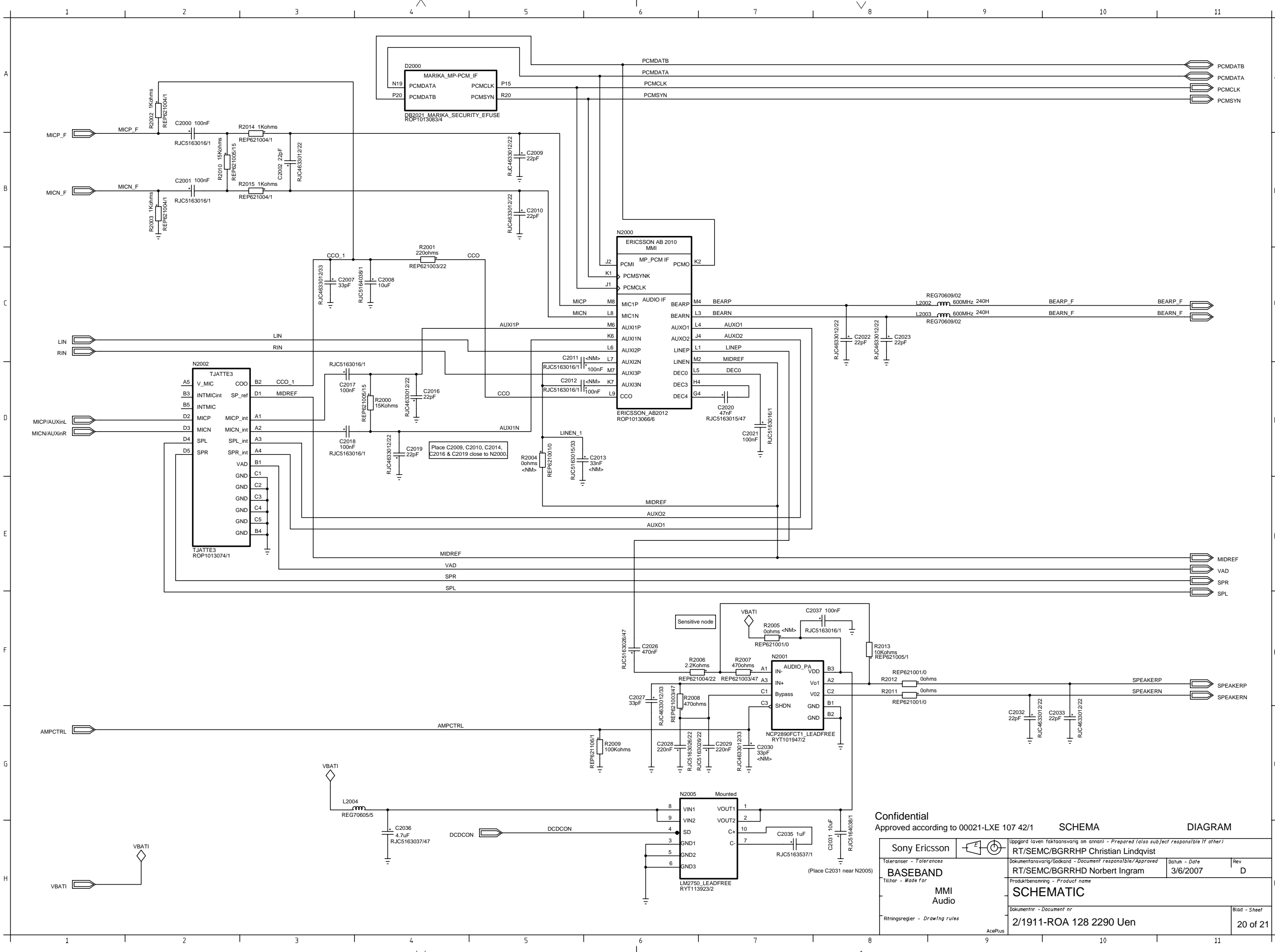

Confidential
Approved according to 00021-LXE 107 42/1

SCHEMA
DIAGRAM

Sony Ericsson	RT/SEMC/BGRRHP Christian Lindqvist	
Toleranser - Tolerances	Dokumentansvarig/Godkänd - Document responsible/Approved	Datum - Date
BASEBAND	RT/SEMC/BGRRHD Norbert Ingram	3/6/2007
Tillhän - Made for	Produktbenämning - Product name	Rev
	SCHEMATIC	D
Ritningsregler - Drawing rules	Dokumentnr - Document nr	Blad - Sheet
	2/1911-ROA 128 2290 Uen	20 of 21

LZF 030 102/F RB

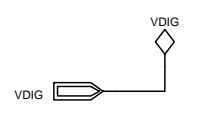
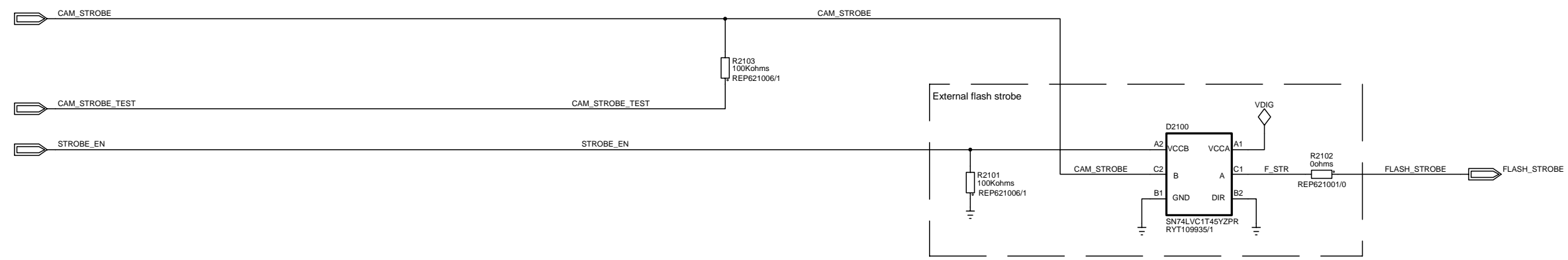

Confidential
 Approved according to 00021-LXE 107 42/1 SCHEMA DIAGRAM

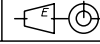
Sony Ericsson 		Uppgord (oven faktaansvarig om annan) - Prepared (also subject responsible if other)	
BASEBAND Tillhan - Made for MMI Camera		RT/SEMC/BGRRHP Christian Lindqvist Dokumentansvarig/Godkand - Document responsible/Approved	Datum - Date 3/6/2007
Ritningsregler - Drawing rules		Produktbenamning - Product name SCHEMATIC	
Dokumentnr - Document nr 2/1911-ROA 128 2290 Uen			Bladd - Sheet 21 of 21