T-Mobile®

G1™

User Manual

May 27, 2009
Android™ mobile technology platform R1.5.0

Please Read Before Proceeding

THE BATTERY IS NOT CHARGED WHEN YOU TAKE IT OUT OF THE BOX.

DO NOT REMOVE THE BATTERY PACK WHEN THE DEVICE IS CHARGING.

YOUR WARRANTY IS INVALIDATED IF YOU OPEN OR TAMPER WITH THE DEVICE'S OUTER CASING.

PRIVACY RESTRICTIONS

Some countries require full disclosure of recorded telephone conversations, and stipulate that you must inform the person with whom you are speaking that the conversation is being recorded. Always obey the relevant laws and regulations of your country when using the recording feature of your device.

INTELLECTUAL PROPERTY RIGHT INFORMATION

Copyright © 2009 HTC Corporation. All Rights Reserved.

HTC, the HTC logo, ExtUSB, HTC Innovation and HTC Care are trademarks and/or service marks of HTC Corporation.

Copyright © 2009 Google Inc. Used with permission.

Google, the Google logo, Android, the Android logo, Android Market, Google Mail, Google Apps, Google Calendar, Google Checkout, Google Earth, Google Latitude, Google Maps, Google Talk, Picasa, and YouTube are trademarks of Google Inc.

T-Mobile is a federally registered trademark of Deutsche Telekom AG.

T-Mobile G1 and G1 are trademarks of T-Mobile USA, Inc.

Microsoft, Windows, and Outlook are either registered trademarks or trademarks of Microsoft Corporation in the United States and/or other countries.

Bluetooth and the Bluetooth logo are trademarks owned by Bluetooth SIG, Inc.

Wi-Fi is a registered trademark of the Wireless Fidelity Alliance Inc.

microSD is a trademark of SD Card Association.

Licensed by QUALCOMM Incorporated under one or more of the following patents:

4,901,307 5,490,165 5,056,109 5,504,773 5,101,501 5,778,338

5,506,865 5,109,390 5,511,073 5,228,054 5,535,239 5,710,784

5,267,261 5,544,196 5,267,262 5,568,483 5,337,338 5,659,569

5,600,754 5,414,796 5,657,420 5,416,797

All other company, product and service names mentioned herein are trademarks, registered trademarks or service marks of their respective owners.

HTC shall not be liable for technical or editorial errors or omissions contained herein, nor for incidental or consequential damages resulting from furnishing this material. The information is provided "as is" without warranty of any kind and is subject to change without notice. HTC also reserves the right to revise the content of this document at any time without prior notice.

No part of this document may be reproduced or transmitted in any form or by any means, electronic or mechanical, including photocopying, recording or storing in a retrieval system, or translated into any language in any form without prior written permission of HTC.

Limitation of Damages

TO THE MAXIMUM EXTENT PERMITTED BY APPLICABLE LAW, IN NO EVENT SHALL HTC OR ITS PROVIDERS BE LIABLE TO USER OR ANY THIRD PARTY FOR ANY INDIRECT, SPECIAL, CONSEQUENTIAL, INCIDENTAL OR PUNITIVE DAMAGES OF ANY KIND, IN CONTRACT OR TORT, INCLUDING, BUT NOT LIMITED TO, INJURY, LOSS OF REVENUE, LOSS OF GOODWILL, LOSS OF BUSINESS OPPORTUNITY, LOSS OF DATA, AND/OR LOSS OF PROFITS ARISING OUT OF, OR RELATED TO, IN ANY MANNER, OR THE DELIVERY, PERFORMANCE OR NONPERFORMANCE OF OBLIGATIONS, OR USE OF THE WEATHER INFORMATION, DATA OR DOCUMENTATION HEREUNDER REGARDLESS OF THE FORESEEABILITY THEREOF.

Important Health Information and Safety Precautions

When using this product, the safety precautions below must be taken to avoid possible legal liabilities and damages.

Retain and follow all product safety and operating instructions. Observe all warnings in the operating instructions on the product.

To reduce the risk of bodily injury, electric shock, fire, and damage to the equipment, observe the following precautions.

ELECTRICAL SAFETY

This product is intended for use when supplied with power from the designated battery or power supply unit. Other usage may be dangerous and will invalidate any approval given to this product.

SAFETY PRECAUTIONS FOR PROPER GROUNDING INSTALLATION

CAUTION: Connecting to an improperly grounded equipment can result in an electric shock to your device.

This product equipped with a USB Cable for connecting with desktop or notebook computer. Be sure your computer is properly grounded (earthed) before connecting this product to the computer. The power supply cord of a desktop or notebook computer has an equipment-grounding conductor and a grounding plug. The plug must be plugged into an appropriate outlet which is properly installed and grounded in accordance with all local codes and ordinances.

SAFETY PRECAUTIONS FOR POWER SUPPLY UNIT

- Use the correct external power source
A product should be operated only from the type of power source indicated on the electrical ratings label. If you are not sure of the type of power source required, consult your authorized service provider or local power company. For a product that operates from battery power or other sources, refer to the operating instructions that are included with the product.
This product should be operated only with the following designated power supply unit(s).

AC Adapter

1. Phihong, Models PSAA05A-050, PSAA05C-050, PSAA05E-050, PSAA05K-050 and PSAA05S-050.
2. HTC, Model TC P300

Car Adapter

Phihong, Model CLA05D-050

- Handle battery packs carefully
This product contains a Li-ion polymer battery. There is a risk of fire and burns if the battery pack is

handled improperly. Do not attempt to open or service the battery pack. Do not disassemble, crush, puncture, short external contacts or circuits, dispose of in fire or water, or expose a battery pack to temperatures higher than 60°C (140°F).



WARNING: Danger of explosion if battery is incorrectly replaced. To reduce risk of fire or burns, do not disassemble, crush, puncture, short external contacts, expose to temperature above 60° C (140° F), or dispose of in fire or water. Replace only with specified batteries. Recycle or dispose of used batteries according to the local regulations or reference guide supplied with your product.



Note This product should be operated only with the following designated Battery Pack(s): HTC, Model DREA160.

- Take extra precautions
 - Keep the battery or device dry and away from water or any liquid as it may cause a short circuit.
 - Keep metal objects away so they don't come in contact with the battery or its connectors as it may lead to short circuit during operation.
 - The phone should be only connected to products that bear the USB-IF logo or have completed the USB-IF compliance program.
 - Do not use a battery that appears damaged, deformed, or discolored, or the one that has any rust on its casing, overheats, or emits a foul odor.
 - Always keep the battery out of the reach of babies and small children, to avoid swallowing of the battery. Consult the doctor immediately if the battery is swallowed.
 - If the battery leaks:
 1. Do not allow the leaking fluid to come in contact with skin or clothing. If already in contact, flush the affected area immediately with clean water and seek medical advice.
 2. Do not allow the leaking fluid to come in contact with eyes. If already in contact, DO NOT rub; rinse with clean water immediately and seek medical advice.
 3. Take extra precautions to keep a leaking battery away from fire as there is a danger of ignition or explosion.

SAFETY PRECAUTIONS FOR DIRECT SUNLIGHT

Keep this product away from excessive moisture and extreme temperatures. Do not leave the product or its battery inside a vehicle or in places where the temperature may exceed 60°C (140°F), such as on a car dashboard, window sill, or behind a glass that is exposed to direct sunlight or strong ultraviolet light for extended periods of time. This may damage the product, overheat the battery, or pose a risk to the vehicle.

PREVENTION OF HEARING LOSS



CAUTION: Permanent hearing loss may occur if earphones or headphones are used at high volume for prolonged periods of time.

Note: For France, Earphone (listed below) for this device have been tested to comply with the Sound Pressure Level requirement laid down in the applicable NF EN 50332-1:2000 and/or NF EN 50332-2:2003 standards as required by French Article L. 5232-1.

- Earphone, manufactured by Cotron, Model HS S200.

SAFETY IN AIRCRAFT

Due to the possible interference caused by this product to an aircraft's navigation system and its communications network, using this device's phone function on board an airplane is against the law in most countries. If you want to use this device when on board an aircraft, remember to turn off your phone by switching to Airplane Mode.

ENVIRONMENT RESTRICTIONS

Do not use this product in gas stations, fuel depots, chemical plants or where blasting operations are in progress, or in potentially explosive atmospheres such as fuelling areas, fuel storehouses, below deck on boats, chemical plants, fuel or chemical transfer or storage facilities, and areas where the air contains chemicals or particles, such as grain, dust, or metal powders. Please be aware that sparks in such areas could cause an explosion or fire resulting in bodily injury or even death.

EXPLOSIVE ATMOSPHERES

When in any area with a potentially explosive atmosphere or where flammable materials exist, the product should be turned off and the user should obey all signs and instructions. Sparks in such areas could cause an explosion or fire resulting in bodily injury or even death. Users are advised not to use the equipment at refueling points such as service or gas stations, and are reminded of the need to observe restrictions on the use of radio equipment in fuel depots, chemical plants, or where blasting operations are in progress. Areas with a potentially explosive atmosphere are often, but not always, clearly marked. These include fueling areas, below deck on boats, fuel or chemical transfer or storage facilities, and areas where the air contains chemicals or particles, such as grain, dust, or metal powders.

ROAD SAFETY

Vehicle drivers in motion are not permitted to use telephony services with handheld devices, except in the case of emergency. In some countries, using hands-free devices as an alternative is allowed.

SAFETY PRECAUTIONS FOR RF EXPOSURE

- Avoid using your phone near metal structures (for example, the steel frame of a building).
- Avoid using your phone near strong electromagnetic sources, such as microwave ovens, sound speakers, TV and radio.
- Use only original manufacturer-approved accessories, or accessories that do not contain any metal.
- Use of non-original manufacturer-approved accessories may violate your local RF exposure guidelines and should be avoided.

INTERFERENCE WITH MEDICAL EQUIPMENT FUNCTIONS

This product may cause medical equipment to malfunction. The use of this device is forbidden in most hospitals and medical clinics.

If you use any other personal medical device, consult the manufacturer of your device to determine if they are adequately shielded from external RF energy. Your physician may be able to assist you in obtaining this information.

Turn your phone OFF in health care facilities when any regulations posted in these areas instruct you to do so. Hospitals or health care facilities may be using equipment that could be sensitive to external RF energy.

HEARING AIDS

Some digital wireless phones may interfere with some hearing aids. In the event of such interference, you may want to consult your service provider, or call the customer service line to discuss alternatives.

NONIONIZING RADIATION

Your device has an internal antenna. This product should be operated in its normal-use position to ensure the radiative performance and safety of the interference. As with other mobile radio transmitting equipment, users are advised that for satisfactory operation of the equipment and for the safety of personnel, it is recommended that no part of the human body be allowed to come too close to the antenna during operation of the equipment.

Use only the supplied integral antenna. Use of unauthorized or modified antennas may impair call quality and damage the phone, causing loss of performance and SAR levels exceeding the recommended limits as well as result in non-compliance with local regulatory requirements in your country.

To assure optimal phone performance and ensure human exposure to RF energy is within the guidelines set forth in the relevant standards, always use your device only in its normal-use position. Contact with the antenna area may impair call quality and cause your device to operate at a higher power level than needed. Avoiding contact with the antenna area when the phone is IN USE optimizes the antenna performance and the battery life.

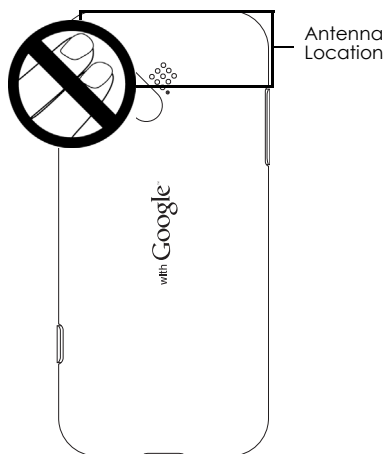

General Precautions

- **Avoid applying excessive pressure to the device**

Do not apply excessive pressure on the screen and the device to prevent damaging them and remove the device from your pockets before sitting down. It is also recommended that you store the device in a protective case and only use the device stylus or your finger when interacting with the touch screen. Cracked display screens due to improper handling are not covered by the warranty.
- **Device getting warm after prolonged use**

When using your device for prolonged periods of time, such as when you're talking on the phone, charging the battery or browsing the web, the device may become warm. In most cases, this condition is normal and therefore should not be interpreted as a problem with the device.
- **Heed service markings**

Except as explained elsewhere in the Operating or Service documentation, do not service any product yourself. Service needed on components inside the device should be done by an authorized service technician or provider.
- **Damage requiring service**

Unplug the product from the electrical outlet and refer servicing to an authorized service technician or provider under the following conditions:

 - Liquid has been spilled or an object has fallen onto the product.
 - The product has been exposed to rain or water.
 - The product has been dropped or damaged.
 - There are noticeable signs of overheating.
 - The product does not operate normally when you follow the operating instructions.
- **Avoid hot areas**

The product should be placed away from heat sources such as radiators, heat registers, stoves, or other products (including amplifiers) that produce heat.
- **Avoid wet areas**

Never use the product in a wet location.
- **Avoid using your device after a dramatic change in temperature**

When you move your device between environments with very different temperature and/or humidity ranges, condensation may form on or within the device. To avoid damaging the device, allow sufficient time for the moisture to evaporate before using the device.

NOTICE: When taking the device from low-temperature conditions into a warmer environment or from high-temperature conditions into a cooler environment, allow the device to acclimate to room temperature before turning on power.
- **Avoid pushing objects into product**

Never push objects of any kind into cabinet slots or other openings in the product. Slots and openings are provided for ventilation. These openings must not be blocked or covered.
- **Mounting accessories**

Do not use the product on an unstable table, cart, stand, tripod, or bracket. Any mounting of the product should follow the manufacturer's instructions, and should use a mounting accessory recommended by the manufacturer.
- **Avoid unstable mounting**

Do not place the product with an unstable base.
- **Use product with approved equipment**

This product should be used only with personal computers and options identified as suitable for use with your equipment.

-
- **Adjust the volume**
Turn down the volume before using headphones or other audio devices.
 - **Cleaning**
Unplug the product from the wall outlet before cleaning. Do not use liquid cleaners or aerosol cleaners. Use a damp cloth for cleaning, but NEVER use water to clean the LCD screen.
 - **Small Children**
Do not leave your phone and its accessories within the reach of small children or allow them to play with it. They could hurt themselves or others, or could accidentally damage the phone. Your phone contains small parts with sharp edges that may cause an injury or which could become detached and create a choking hazard.
 - **Repetitive Motion Injuries**
To minimize the risk of RSI, when Texting or playing games with your phone:
 - Do not grip the phone too tightly
 - Press the buttons lightly
 - Make use of the special features in the handset which minimize the number of buttons which have to be pressed, such as message templates and predictive text.
 - Take lots of breaks to stretch and relax.
 - **Bright Light**
This phone is capable of producing flash of light or use as a torch, do not use it too close to the eyes.
 - **Operating machinery**
Full attention must be given to operating the machinery in order to reduce the risk of an accident.
 - **Electrostatic discharge (ESD)**
Do not touch the SIM card's metal connectors.
 - **Seizures/Blackouts**
This phone is capable of producing bright flashing lights.
 - **Loud Noise**
This phone is capable of producing loud noises which may damage your hearing.
 - **Emergency Calls**
This phone, like any wireless phone, operates using radio signals, which cannot guarantee connection in all conditions. Therefore, you must never rely solely on any wireless phone for emergency communications.

Contents

| | |
|--|-----------|
| 1 Phone Basics | 14 |
| 1.1 Getting to Know Your T-Mobile G1 and Accessories | 14 |
| Front panel | 14 |
| Keyboard | 15 |
| Left and right panels | 16 |
| Bottom panel | 16 |
| Inside the box | 16 |
| 1.2 Installing the SIM Card, Battery, and Storage Card | 17 |
| SIM card | 17 |
| Battery | 18 |
| Storage card | 19 |
| 1.3 Charging the Battery | 20 |
| 1.4 Phone Controls | 21 |
| 1.5 Getting Around Your Phone | 21 |
| Touch | 21 |
| Touch and hold | 22 |
| Swipe or slide | 22 |
| Drag | 22 |
| Flick | 22 |
| Rotate | 22 |
| Use the Trackball | 22 |
| 1.6 Getting Started | 22 |
| Turn your phone on and off | 22 |
| Enter PIN | 23 |
| Set up your phone for the first time | 23 |
| Retrieve your Google™ password | 23 |
| Turn off the screen when not in use | 23 |
| 1.7 Home Screen | 24 |
| Extended Home screen | 24 |
| Customizing the Home screen | 25 |
| 1.8 Phone Status and Notifications | 26 |
| Status bar | 26 |
| Notifications panel | 27 |
| Notification LED | 28 |
| 1.9 Applications | 29 |
| Recently-used applications | 29 |
| 1.10 Settings | 29 |
| 1.11 Adjusting the Volume | 30 |
| 1.12 Using the Phone's Storage Card as a USB Drive | 31 |
| 2 Entering Text | 32 |
| 2.1 Using the Hardware Keyboard | 32 |
| SEARCH key | 32 |

| | |
|---|----|
| MENU key | 33 |
| ALT key | 33 |
| SHIFT key | 33 |
| @ key | 33 |
| Typing and text navigation tips | 33 |
| 2.2 Using the Onscreen Keyboard | 34 |
| Adjusting keyboard settings | 35 |
| Using the landscape onscreen keyboard | 35 |
| Entering numbers and symbols | 35 |

3 Using Phone Features and Managing Contacts 36

| | |
|---|----|
| 3.1 Making Calls | 36 |
| Make a call by speaking | 37 |
| Make a call from the Call log | 37 |
| Add and call your contacts | 37 |
| Add and call favorite contacts | 38 |
| Call voicemail | 38 |
| 3.2 Answering or Rejecting Calls | 39 |
| 3.3 Call Options | 39 |
| Manage multiple calls | 41 |
| Set up a conference call | 41 |
| 3.4 Using the Call Log | 41 |
| 3.5 Adjusting Phone Settings | 43 |
| 3.6 Turning the Phone Function On and Off | 43 |
| 3.7 Creating and Managing Your Contacts | 43 |
| Add a new contact | 44 |
| Edit and customize your contacts | 45 |
| Communicate with your contacts | 46 |

4 Managing Your Time 48

| | |
|---|----|
| 4.1 Using Calendar | 48 |
| Open Calendar | 48 |
| Create events | 48 |
| Calendar views | 49 |
| Event reminders | 49 |
| Synchronize Microsoft® Office Outlook® calendar | 50 |
| 4.2 Using Alarm Clock | 50 |
| Set an alarm | 50 |
| Customize Alarm Clock | 51 |
| Delete an alarm | 51 |
| Silence all alarms | 51 |

5 Exchanging Messages 52

| | |
|---|----|
| 5.1 Sending Text and Multimedia Messages | 52 |
| Open Messaging | 52 |
| Create and send SMS and MMS messages | 52 |
| Receive text and multimedia messages | 55 |
| Manage messages and message threads | 55 |
| Adjust text and multimedia message settings | 57 |
| 5.2 Using Google Mail™ | 58 |

| | |
|--|-----------|
| Create and send emails | 58 |
| Receive and read emails | 59 |
| Reply to or forward emails | 60 |
| Manage conversations and emails | 61 |
| Set Google Mail settings | 61 |
| 5.3 Using Email. | 62 |
| Add an email account | 62 |
| Compose and send emails | 62 |
| Manage emails on your external email account | 63 |
| Edit or delete an external email account | 63 |
| Add more email accounts | 63 |
| 5.4 Using Google Talk™ | 63 |
| Sign in and chat online | 63 |
| Manage your friends | 65 |
| Mobile indicators | 66 |
| Adjust instant messaging settings | 66 |
| Sign out | 66 |
| 6 Getting Connected | 67 |
| 6.1 Connecting to the Internet | 67 |
| GPRS/3G/EDGE | 67 |
| Wi-Fi | 67 |
| 6.2 Using Browser | 69 |
| View web pages | 69 |
| Manage links, history, and downloads | 71 |
| Manage bookmarks | 73 |
| Adjust Browser settings | 73 |
| 6.3 Using Bluetooth | 74 |
| 7 Getting Around with Maps | 76 |
| 7.1 Using Maps | 76 |
| Enable Location source | 76 |
| Open Maps | 76 |
| Find your location on the map | 76 |
| 7.2 Searching for Places of Interest | 77 |
| 7.3 Viewing Maps | 78 |
| Zoom in or out on a map | 78 |
| Navigate on a map | 78 |
| 7.4 Getting Directions | 79 |
| 7.5 Finding your friends with Google Latitude™ | 81 |
| Open Latitude | 81 |
| Share your locations | 81 |
| Invite friends | 81 |
| Accept an invitation | 81 |
| Show your friends | 82 |
| Connect with your friends | 82 |
| Control what you share | 83 |
| 8 Camera and Multimedia | 84 |
| 8.1 Using Camera and Camcorder | 84 |

| | |
|--|------------|
| Capture modes | 84 |
| Take pictures | 85 |
| Shoot videos | 85 |
| Post capture | 85 |
| Copying photos and video to storage | 86 |
| 8.2 Using Gallery | 86 |
| Work with pictures | 87 |
| Work with videos | 89 |
| 8.3 Viewing Videos on YouTube™ | 90 |
| Watch YouTube videos | 90 |
| Search for videos | 91 |
| 8.4 Using Music | 91 |
| Music library | 91 |
| Play music | 92 |
| Use playlists | 92 |
| Set a song as ring tone | 93 |
| Delete music on the storage card | 94 |
| 9 Using Android Market™ | 95 |
| 9.1 Using Android Market | 95 |
| 9.2 Getting help | 96 |
| 9.3 Finding applications | 96 |
| 9.4 Installing an application | 96 |
| 9.5 Purchasing an application | 97 |
| Request a refund | 98 |
| 9.6 Managing your applications | 98 |
| 9.7 Uninstalling an application | 99 |
| 10 Managing Your Phone | 100 |
| 10.1 Changing Basic Settings | 100 |
| Set the date, time zone, and time | 100 |
| Display settings | 100 |
| Ringer settings | 101 |
| Phone services | 101 |
| Language settings | 102 |
| 10.2 Protecting Your Phone | 102 |
| Protect your SIM card with a PIN | 102 |
| Protect your phone with a screen lock | 102 |
| 10.3 Managing Memory | 103 |
| 10.4 Software Updates | 104 |
| 10.5 Synchronizing Google Applications™ | 104 |
| 10.6 Resetting the Phone | 105 |
| 11 Appendix | 106 |
| 11.1 A.1 Specifications | 106 |
| 11.2 A.2 Regulatory Notices | 107 |
| Regulatory Agency Identifications | 107 |
| Federal Communications Commission Notice | 107 |
| Modifications | 108 |
| Body-worn operation | 108 |



Safety Precautions for Radio Frequency Exposure108
FCC RF Radiation Exposure Statement108
Exposure to Radio Frequency (RF) Signals108
SAR Information **109**
Telecommunications & Internet Association (TIA) Safety Information.....109
WEEE Notice110
RoHS Compliance110

Index 111



1 Phone Basics

1.1 Getting to Know Your T-Mobile G1 and Accessories

Front panel

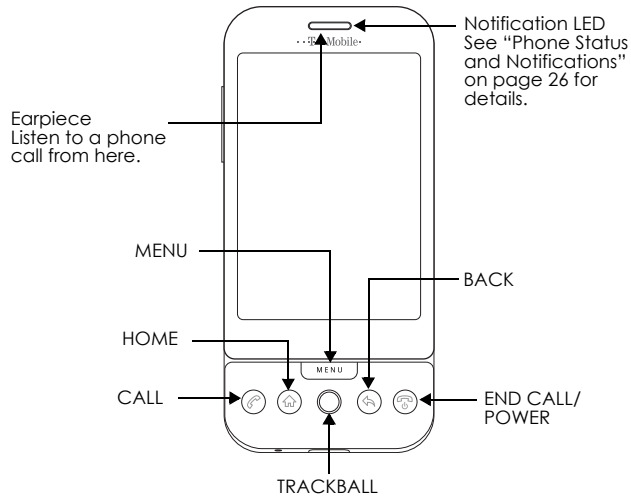

For more information about the functions of the **MENU**, **HOME**, **CALL**, **END CALL/POWER** and **BACK** buttons, refer to "Phone Controls" on page 21 for more details. For more information about the **TRACKBALL**, refer to "Use the Trackball" on page 22.

Keyboard

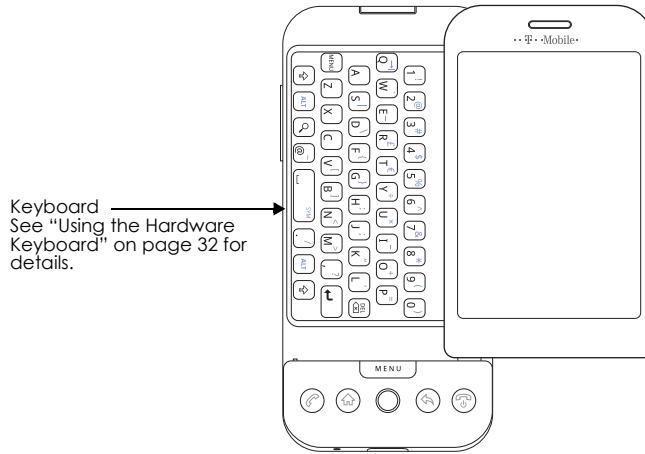

Back panel

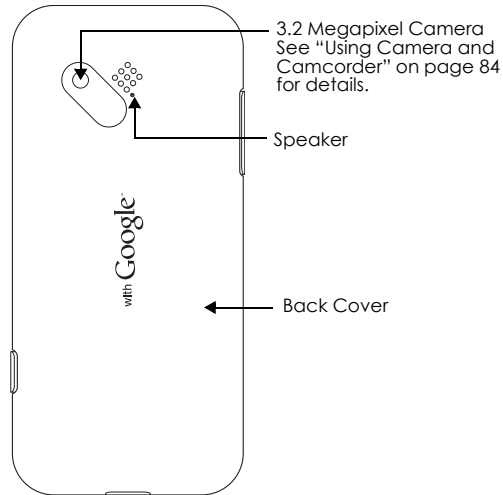

Left and right panels

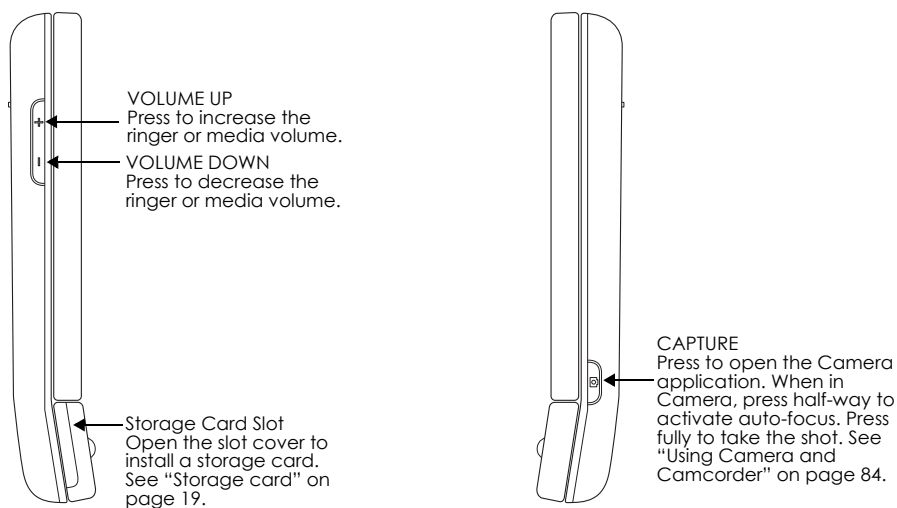

Bottom panel

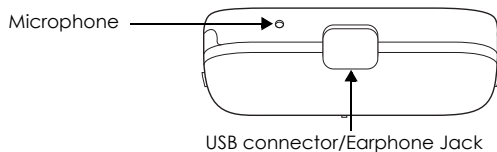

Flip open the cover to connect the:

- USB cable to transfer files.
- AC adapter to recharge the battery.
- USB stereo headset for hands-free conversation or for listening to music and videos.

Inside the box

The product package includes the following items and accessories:

- Battery
- USB cable
- AC adapter
- Wired stereo headset
- Pouch
- 1GB microSD™ card
- Quick Start Guide

1.2 Installing the SIM Card, Battery, and Storage Card

Always turn off your phone before installing or replacing the SIM card, battery, and storage card. You also need to remove the back cover before you can install the SIM card and battery.

To remove the back cover

- 1 Make sure the phone is turned off.
- 2 Hold the phone sideways with the control buttons on the right, then slide the display panel up to reveal the keyboard.
- 3 Locate the back cover release tab to the left of the keyboard, then push the tab up with your thumb until the back cover disengages from the device.
- 4 Gently push down the release tab with your finger until the back cover disengages from the device.

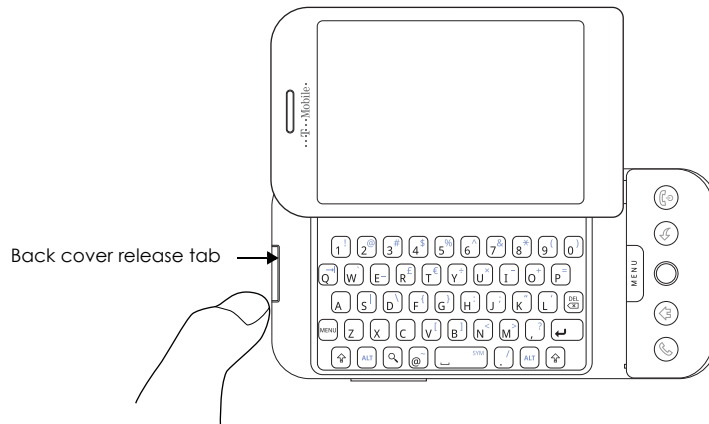

- 5 Pull back cover out then set it aside.

SIM card

The SIM card contains your phone number, service details, and phone book/message memory. Your phone supports both 1.8V and 3V SIM cards.

Note Some legacy SIM cards may not function with your phone. You should consult your wireless service provider for a replacement SIM card. There may be fees for this service.

To install the SIM card

- 1 Make sure the phone is turned off.
- 2 Locate the SIM card slot, then insert the SIM card with its gold contacts facing down and its cut-off corner facing out the card slot.
- 3 Slide the SIM card completely into the slot.

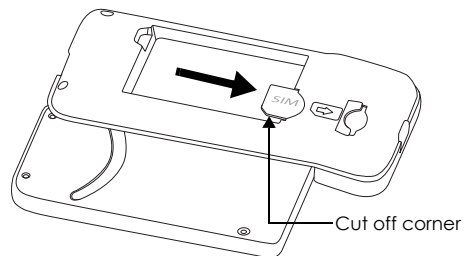

To remove the SIM card

- 1 Remove the back cover and the battery if it is installed.
- 2 Locate the groove below the SIM card slot, then push the SIM card out of the slot with your finger.

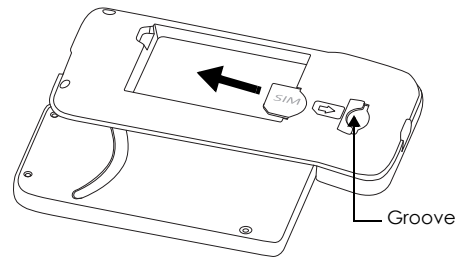

Battery

Your phone comes with a rechargeable Lithium-ion battery and is designed to use only manufacturer-specified original batteries and accessories. Battery performance depends on many factors, including network configuration, signal strength, the temperature of the environment in which you operate your phone, the features and/or settings you select and use, items attached to connecting ports, and your voice, data, and other program usage patterns.

Battery life estimates (approximations):

Talk time:

- Up to **350** minutes for WCDMA
- Up to **406** minutes for GSM

Standby time:

- Up to **402** hours for WCDMA
- Up to **319** hours for GSM

Note Battery life is subject to network and phone usage.

Warning! To reduce risk of fire or burns:

- Do not attempt to open, disassemble, or service the battery pack.
- Do not crush, puncture, short external contacts, or dispose of in fire or water.
- Do not expose to temperatures above 60°C (140°F).
- Replace only with the battery pack designated for this product.
- Recycle or dispose of used battery as stipulated by local regulations.

To install the battery

- 1 Align the battery's exposed copper contacts with the battery connectors inside the battery compartment.
- 2 Insert the contact side of the battery first then gently push the battery into place.
- 3 Replace the back cover.

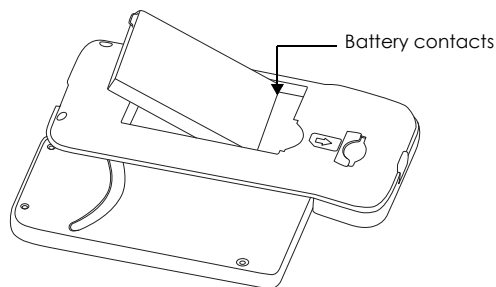

To remove the battery

- 1 Make sure the phone is turned off.
- 2 Remove the back cover.
- 3 The top side of the battery has a protruding grip. Lift the battery from the grip to remove it.

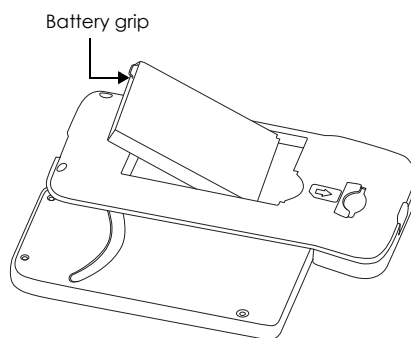

Storage card

To store your pictures, music, and applications, install the supplied microSD card into your phone.

Note You need to install the microSD card before you can use the Camera application.

To install the storage card

- 1 Make sure that your phone is turned off.
- 2 Hold the device sideways, then slide the display up to reveal the keyboard.
- 3 Push the slot cover downward through the small bump on the left edge of the slot cover to reveal the microSD card slot.

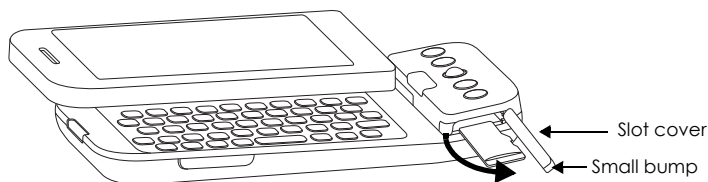

- 4 Insert the microSD card into the slot with its copper contacts facing down and its notched edge facing right.

-
- 5 Push the card gently into the slot until it clicks into place.
 - 6 Replace the slot cover.

Note Make sure that both ends of the cover are properly seated on the slot. The phone does not recognize the microSD card if the slot cover is not properly replaced.

To remove the storage card

- 1 Make sure that the device is turned off.
- 2 Slide up the keyboard, then open the storage card slot cover.
- 3 Push the microSD card inward until it clicks, then release it to eject it from the slot.
- 4 Replace the storage card slot cover.

Note If you want to remove the storage card while the device is on, see "To safely remove the storage card while the phone is on" on page 31.

1.3 Charging the Battery



New batteries are not charged when shipped. Before you start using your phone, you need to install and charge the battery. Some batteries perform best after several full charge/discharge cycles.

To charge the battery

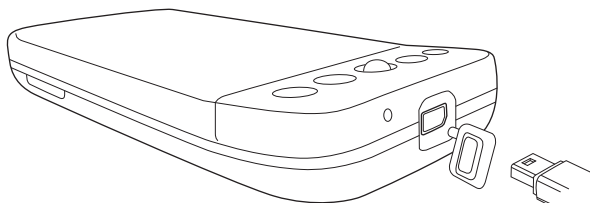
- 1 Plug the USB connector of the AC adapter to the USB connector at the bottom of your phone.
- 2 Plug in the AC adapter to an electrical outlet to start charging the battery.



Note Only the AC adapter and USB cable provided with your phone must be used to charge the battery.

Charging is indicated by a solid red light in the Notification LED. As the battery is being charged while the phone is on, the charging battery icon  is displayed in the status bar of the Home screen. After the battery has been fully charged, the Notification LED shows a solid green light and a full battery icon  displays in the status bar of the Home screen.

For more information about the Notification LED, refer to "Phone Status and Notifications" on page 26.

Warning:

- Do not remove the battery from the phone while you are charging it using the AC or car adapter.
- As a safety precaution, the battery stops charging when it overheats.

1.4 Phone Controls

Press the control buttons on the front panel of your phone to do the following:

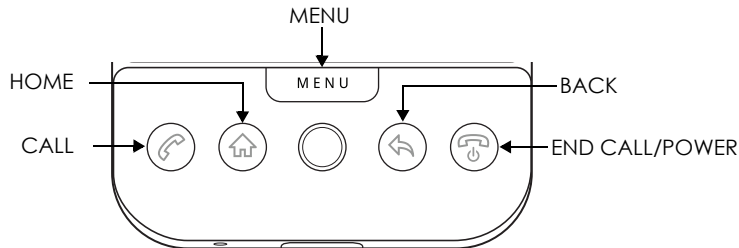

| | |
|-----------------------|---|
| MENU | <ul style="list-style-type: none">• Press to open a list of actions that you can do on the current screen or options menu. |
| HOME | <ul style="list-style-type: none">• While on any application or screen, press to return to the Home screen.• Press and hold to open the recently-used applications window. |
| CALL | <ul style="list-style-type: none">• Press to open the Call log tab.• When a contact, contact number, or phone number is highlighted on the screen, press to call the contact or phone number.• If you navigated to another application during a call, press to display the ongoing call on the screen.• Press and hold to open the Voice Dialer. |
| END CALL/POWER | <ul style="list-style-type: none">• While in a call, press to hang up.• While not on a call, press and hold to open the phone options menu that allows you to turn off the phone, put your phone in silent mode, or turn on/off Airplane mode. |
| BACK | <ul style="list-style-type: none">• Press to go back to the previous screen, or to close a dialog box, options menu, or the Notifications panel.• Press and hold to return to the main screen of the current application.• When the onscreen keyboard is open, press to close the onscreen keyboard. |

1.5 Getting Around Your Phone

There are different ways to navigate around the Home screen, menus and application screens on your phone. You can also change the screen orientation of the phone.

Touch

When you want to type using the onscreen keyboard, select items onscreen such as application and settings icons, or press onscreen buttons, simply touch them with your finger.

Touch and hold

To open the available options for an item (for example, contact or link in a webpage), simply touch and hold the item.

Swipe or slide

To swipe or slide means to quickly drag your finger vertically or horizontally across the screen.

Drag

Touch and hold your finger with some pressure before you start to drag. While dragging, do not release your finger until you have reached the target position.

Flick

Flicking the screen is similar to swiping, except that you need to swipe your finger in light, quicker strokes. This finger gesture is always in a vertical direction, such as when flicking the contacts or message list.

Rotate

You can automatically change the screen orientation from portrait to landscape by turning the phone sideways. When entering text using the onscreen keyboard, you can turn the phone sideways to bring up a bigger keyboard. Refer to "Entering Text" on page 32 for more details.

Notes

- The screen orientation is fixed to landscape when the hardware keyboard is open.
- The **Orientation** check box in **HOME > MENU > Settings > Sound & display** needs to be selected for the screen orientation to automatically change.

Use the Trackball

Roll or press the **TRACKBALL** to select or highlight items on the screen. The **TRACKBALL** also flashes when you receive an incoming call or a notification.

1.6 Getting Started

Once you've installed your SIM card, battery, and microSD card, you can turn on your phone and start using it.

Turn your phone on and off

To turn on the phone

Press the **END CALL/POWER** button.

Note When you turn on the phone for the first time, you will be prompted to sign in to your Google™ Account. For more information, refer to "Set up your phone for the first time" on page 23.

To turn off the phone

- 1 Press and hold the **END CALL/POWER** button until the options menu opens.
- 2 On the options menu, touch **Power off**.
- 3 Touch **OK** when prompted to turn off the phone.

Enter PIN

If your SIM card is preset with a PIN (personal identification number), you will be prompted to enter the PIN before you can use the phone. Enter the SIM PIN, then touch **OK**. To learn how to enable or disable the SIM PIN, refer to "Protect your SIM card with a PIN" on page 102.

Important If you entered the wrong PIN three times, the SIM card will be blocked and you will not be able to use your phone. If this happens, you can unblock it with the PUK (PIN Unblocking Key) obtained from your wireless service provider. Refer to "To restore a SIM card that has been locked out" on page 102 to learn how to unblock the SIM card.

Set up your phone for the first time

When you turn on the phone for the first time and after touching the Android™ image, you will be prompted to sign in to your Google Account.

Important You will need to know your Google password to sign in. If you have forgotten your password, refer to "Retrieve your Google™ password" in this chapter for details.

Note Make sure that your phone has an active data connection (3G/GPRS) before you sign in to your Google Account. Refer to "Phone Status and Notifications" on page 26 to know if your phone has an active data connection.

1 Touch **Skip**.

Tip Touch **Begin** to view a tutorial on how to use the onscreen keyboard.

2 Touch **Sign in**. Push the screen panel up to reveal the keyboard.

3 Enter your user name and password, then touch **Sign in**. After signing in, all emails, contacts, and calendar events on your Google Account will automatically synchronize with your phone.

Tip Touch **Create** if you do not have a Google Account yet. You need a Google Account to use Google services.

4 Read the setup information on the screen, then touch **Next**.

5 Set up the date and time and then touch **Next**.

6 Touch **Finish setup**.

Retrieve your Google™ password

1 On your computer, open your browser and go to <http://google.com>.

2 On the upper-right side of the web page, click **Sign in**.

3 On the right side of the page, click **I cannot access my account**.

4 In the **Please select your issue** section, select **I forgot my password**.

5 Click **Reset your password now**, and then follow the procedure for recovering your password.

Turn off the screen when not in use

To save battery power, the phone automatically turns off the screen when you leave it idle after a certain period of time. You will still be able to receive messages and calls while the phone's screen is off.

Tip For information on how to adjust the time before the screen turns off, refer to "To adjust the time before the screen turns off" on page 100.

You can also turn off the screen by pressing the **END CALL/POWER** button. Pressing any of the control buttons again or incoming calls will turn on your phone screen.

Note If you have set up a screen unlock pattern, you will be prompted to draw the pattern on the screen before it unlocks. For more information on how to create and enable the screen unlock pattern, refer to "Protect your phone with a screen lock" on page 102.

1.7 Home Screen

The Home screen is your starting point for using the applications on your phone. You can customize the Home screen to display application icons, shortcuts, folders, and widgets.

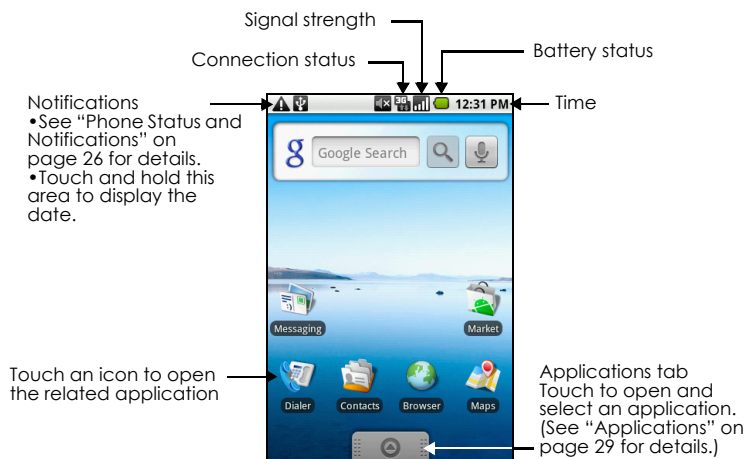

Tip While in any application, press **HOME** to go back to the Home screen.

Extended Home screen

The Home screen extends beyond the screen width to provide more space for adding icons, widgets, and more. Press **HOME**, then slide your finger horizontally across the screen to go to the left or right side of the extended Home screen.

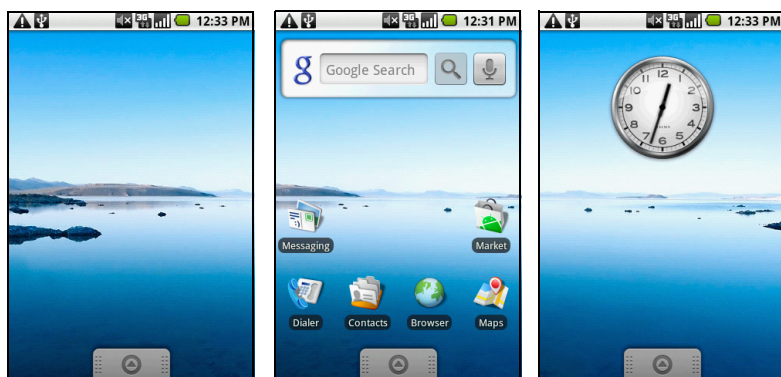

Extended Home screen left

Extended Home screen right

Tip While on an extended Home screen, you can also press **HOME** to return to the main Home screen.

Customizing the Home screen

To add a Home screen item

- 1 Press **HOME**, then touch and hold an empty area on the screen.
- 2 When the Add to Home options menu opens, select the item you want to add to the Home screen:
 - **Shortcuts.** Add shortcuts such as applications, a bookmarked web page, a favorite contact, a Google Mail label, or a music playlist.
Tip To quickly add an application shortcut that is on the Applications tab to the Home screen, touch and hold an application icon. When the phone vibrates, release the icon on an empty area on the Home screen.
 - **Widgets.** Add a clock, music player, a picture frame, the Google Search bar, or a calendar that shows upcoming appointments.
Note If you installed applications from Android Market that have widgets, those widgets will also appear here.
 - **Folders.** Add a folder where you can organize Home screen items, a shortcut to all your contacts, contacts with phone numbers, or starred contacts. Add a shortcut to all your contacts, contacts with phone numbers, or starred contacts. Contact details are automatically updated when there are changes in the source.
For more information on how to create folders, refer to "To create a folder and add items to it" on page 26.
 - **Wallpapers.** Change the Home screen wallpaper. For more information about customizing the wallpaper, refer to "To change the Home screen wallpaper" on page 25.

To reposition a Home screen item

- 1 Touch and hold the item on the screen you want to reposition to activate Move mode.
Note When Move mode is activated, the item magnifies and the phone vibrates.
- 2 Without lifting your finger, drag the icon to the desired position on the screen, then release it.
Note To move an item from the Home screen to an extended Home screen, touch and hold the item and then drag it to the left or right edge of the screen until the display shifts to the extended Home screen. Position the item on the screen, then release it.

To remove a Home screen item

- 1 Touch and hold the item on the screen you want to remove to activate Move mode.
Note When Move mode is activated, the item magnifies and the phone vibrates.
- 2 Drag the icon to the Applications tab (The Applications tab changes into )
- 3 When the icon and Application tab turn red, release it.

To change the Home screen wallpaper

- 1 While on the Home screen, press **MENU** and then touch **Wallpaper**.
- 2 Touch **Pictures** or **Wallpaper gallery**.
 - Touch **Pictures** to use a picture that you have captured using the camera or copied to your phone as a wallpaper. You can crop the picture before setting it as a wallpaper. Refer to "To crop a picture" on page 88 to learn how to crop the picture.
 - Touch **Wallpaper gallery** to use preset wallpapers that came with the phone.
- 3 Touch **Save** or **Set wallpaper**.

To create a folder and add items to it

You can create folders on the Home screen to hold application icons or shortcuts.

- 1 Press **HOME**, press **MENU**, and then touch **Add > Folders**. A new folder appears on the screen.
- 2 Touch and hold an application icon or a shortcut on the Home screen to activate Move mode, then drag it on top of the folder.

To access the items inside a folder, touch the folder to open it and then touch the icon of the application or shortcut you want to open.

Tip To delete a folder, follow the same procedure when you want to remove a Home screen item. Refer to "To remove a Home screen item" on page 25 for details.

To rename a folder

- 1 Touch the folder to open it.
- 2 Touch and hold the folder's title bar to open the Rename folder dialog box.
- 3 Enter the Folder name and then touch **OK**.

1.8 Phone Status and Notifications

Status bar

On top of the phone screen is the status bar. The left side of the status bar displays notification icons while the right side of the status bar displays the phone status.



















Tip When the status bar is full, touch  to display hidden icons/notifications.





Notification icons

These are the icons that may appear on the notifications area of the status bar:



Icons that appear in the boxed area



























| | |
|---|--|
|  New email message |  More (not displayed) notifications |
|  New SMS/MMS |  Call in progress |
|  Problem with SMS/MMS delivery |  Missed call |
|  New instant message |  Call on hold |
|  New voicemail |  Call forwarding on |
|  Upcoming event |  Compass needs orientation |
|  Song is playing |  Uploading data |
|  Problem with sign-in/sync |  Downloading data |
|  Storage card is full |  Content downloaded |

| Icons that appear in the boxed area | |
|---|---|
|  | Wi-Fi is on and wireless networks are available |
|  | Phone connected to computer via USB cable |
|  | Uploading picture to Picasa™ |
|  | Upload to Picasa finished |

Status icons

These are the icons that may appear on the status area of the status bar:



| Icons that appear in the boxed area | |
|---|---------------------------------------|
|  | GPRS connected |
|  | GPRS in use |
|  | EDGE connected |
|  | EDGE in use |
|  | 3G connected |
|  | 3G in use |
|  | Connected to a Wi-Fi network |
|  | Bluetooth is on |
|  | Connected to another Bluetooth device |
|  | Airplane mode |
|  | Alarm is set |
|  | Signal strength |
|  | Speakerphone on |
|  | Roaming |
|  | No signal |
|  | No SIM card installed |
|  | Vibrate mode |
|  | Phone speaker is mute |
|  | Phone microphone is mute |
|  | Battery is very low |
|  | Battery is low |
|  | Battery is full |
|  | Battery is charging |
|  | GPS is on |
|  | GPS is connected |
|  | Data is syncing |

Notifications panel

Notification icons report the arrival of new messages, calendar events, alarms set and ongoing settings such as when call forwarding is on or the current call status. You can open the Notifications panel to open the message, reminder, or event notification and see the wireless service provider name.

To open the Notifications panel

When a new notification icon displays in the status bar, touch and hold the status bar, then slide your finger downward to open the Notifications panel.

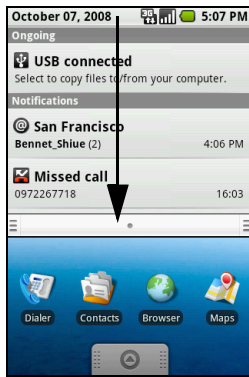

Touch a notification to open the related application

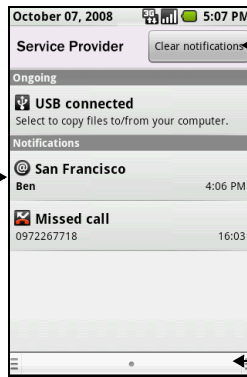

Touch to clear all notifications

Touch and hold, then slide up to close the Notifications panel

If you have several notifications, you can scroll down the screen to view more notifications.

Tip You can also open the Notifications panel on the Home screen by pressing **MENU** and then touching **Notifications**.

To close the Notifications Panel

Touch and hold the bottom bar of the Notifications panel, then slide your finger up the screen or press **BACK**.

Notification LED

The Notification LED located at the right corner of the earpiece provides information on the phone status or pending notifications.

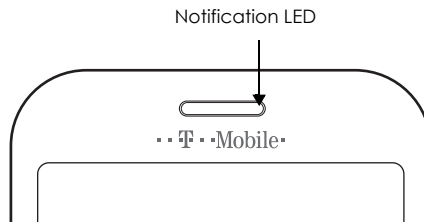

| LED Status | Indication |
|-----------------------|---|
| Solid green | Battery is fully charged (When the phone is being charged using the AC adapter or connected to the computer). |
| Solid red | Battery is charging |
| Flashing red | Battery is low |
| Flashing green | You have a pending notification |

Note The indicators are listed in order of priority. For example, if your phone is connected to a power adapter and is charging the battery, the LED will be solid red and will not switch to a flashing green light even if there is a pending notification.

1.9 Applications

The Applications tab holds all applications on your phone. All applications that you downloaded and installed from Android Market or from the web are also added to the Applications tab.

To open the Applications tab

Press **HOME**, then touch . You can also touch the Application tab and then drag it up to open it.

Tip To open applications quickly, you can add the icons of frequently-used applications to the Home screen or to folders which you have created. For details, refer to "Customizing the Home screen" on page 25.

To close the Applications tab

Touch .

Recently-used applications

To open a recently-used application

- 1 Press and hold the **HOME** button to open the recently-used applications window. The window displays the last six applications you have used.
- 2 Touch an icon in the window to open the related application.

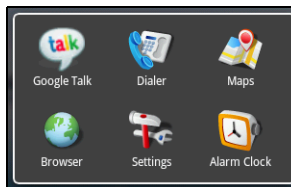

1.10 Settings

Control and customize phone settings on the Settings screen.

To open the Settings screen, do one of the following:

- Press **HOME**, then press **MENU**, and then touch **Settings**.
- Press **HOME**, then open the Applications tab, and then touch **Settings**.

| | |
|----------------------------|---|
| Wireless controls | Configure your phone's wireless connections, such as Wi-Fi and Bluetooth, enable the Airplane mode, or set the options for roaming, networks, and more. See "Getting Connected" on page 67 for details. |
| Call settings | Set up call services such as voicemail, call forwarding, call waiting, and caller ID. See "Using Phone Features and Managing Contacts" on page 36 for details. |
| Sound & display | Set the call and notification ring tones, or set the screen brightness and screen timeout. See "Managing Your Phone" on page 100 for details. |



| | |
|------------------------------------|---|
| Data synchronization | Select which Google™ Applications to synchronize. See "Synchronizing Google Applications™" on page 104 for details. |
| Security & Location | Select the GPS location source to use, set the screen unlock pattern, or enable the SIM card lock. See "Getting Around with Maps" on page 76 and "Managing Your Phone" on page 100 for details. |
| Applications | Manage applications and installation of new programs. |
| SD card & phone storage | Check the available storage card and phone memory, reset the phone to its factory default settings, or format the SD card. See "Managing Your Phone" on page 100 for details. |
| Date & time | Set the date, time, time zone, and date or time format. See "Set the date, time zone, and time" on page 100. |
| Locale & text | Set the operating system language and region. You can also set onscreen keyboard options. |
| About phone | View the phone status such as the network type, signal strength, battery power level, and network name. You can also view the legal information and software version of your phone. |

1.11 Adjusting the Volume

Adjusting the Ringer volume changes the volume level of the phone ring tone, whereas adjusting the Media volume changes the volume level of sound notifications and music or video playback. The ringer volume and media volume can be separately adjusted.

To adjust the Ringer volume

You can adjust the Ringer volume when you are on the Home screen or any application screens (except during a call or when playing music/video).

- 1 Press the **VOLUME UP** or **VOLUME DOWN** buttons on the left panel of the phone to adjust the ringer volume to your desired level. The Ringer volume window appears on the screen to display the volume levels.
- 2 While in the lowest ringer volume level, press **VOLUME DOWN** once to set your phone to Vibrate mode. The phone vibrates and the vibrate mode icon  appears on the status bar.
- 3 While in Vibrate mode, press **VOLUME DOWN** once to turn off the sound of your phone. The speaker mute icon  displays on the status bar.

Tip To quickly switch your phone to silent mode, press and hold the **END CALL/POWER** button, then touch **Silent mode** on the options menu.

You can also adjust the ringer volume on the Settings screen. To adjust, press **HOME**, then press **MENU**, and then touch **Settings > Sound & display > Ringer volume**.

To adjust the media volume

When playing music or watching video, press the **VOLUME UP** or **VOLUME DOWN** buttons on the left panel of the phone to adjust the media volume. The Music/video volume window appears on the screen to display the volume level.

You can also adjust the media volume on the Settings screen.

- 1 Press **HOME**, then press **MENU**, and then touch **Settings**.
- 2 Touch **Sound & display > Media volume**.

-
- 3 When the Media volume window appears, move the slider to the left (to lower the volume) or to the right (to increase the volume).
 - 4 Touch **OK** to close the window.

1.12 Using the Phone's Storage Card as a USB Drive

To transfer music, pictures, and other files from your computer to your phone's storage card, you need to set the phone's storage card as a USB drive.

To set the phone's storage card as a USB drive

- 1 Connect the phone to the computer using the USB cable. A notification icon appears in the status bar.
- 2 Open the Notifications Panel. Refer to "To open the Notifications panel" on page 27 to learn how to open the Notifications Panel.
- 3 In the Notifications Panel, touch **USB connected** and then touch **Mount**.

When you select **Mount**, the phone will not recognize the storage card when it is connected to a computer. You will not be able to use some of the phone's applications such as Camera. You need to turn off USB storage for the phone to recognize the storage card when the phone is connected to a computer. Refer to the next procedure to learn how to turn off USB storage.

To turn off USB storage

- 1 Open the Notifications Panel. Refer to "To open the Notifications panel" on page 27 to learn how to open the Notifications Panel.
- 2 In the Notifications Panel, touch **Turn off USB storage** and then touch **Turn Off**.

To safely remove the storage card while the phone is on

When you need to remove the storage card while the phone is on, you must unmount the storage card first to prevent corrupting or damaging the storage card.

- 1 Press **HOME**, then press **MENU**, and then touch **Settings**.
- 2 Scroll down the screen, then touch **SD card & phone storage**.
- 3 Touch **Unmount SD card**.
- 4 Remove the storage card by following the instructions in "To remove the storage card" on page 20.

To format the SD card

- 1 Press **HOME**, then press **MENU**, and then touch **Settings**.
- 2 Scroll down the screen, then touch **SD card & phone storage**.
- 3 Touch **Unmount SD card**. This enables the **Format SD card** option.
- 4 Touch **Format SD card > Format SD card**.

2 Entering Text

2.1 Using the Hardware Keyboard

When you start an application or select a field that requires text or numbers, you can open and use the QWERTY keyboard to enter information. The keyboard is similar to a standard keyboard on your computer.

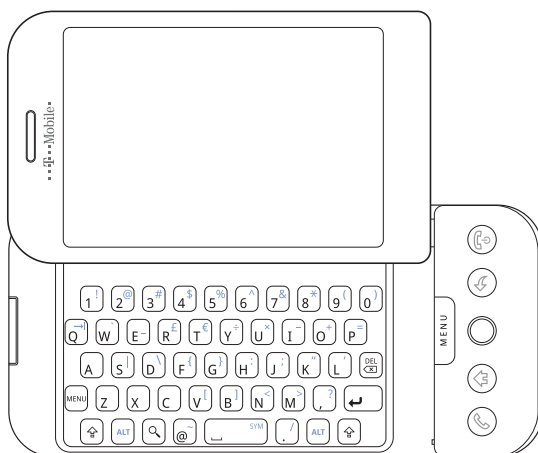

SEARCH key

There is a **SEARCH** key  (just to the left of @), which you can use when the keyboard is open. Press **SEARCH** to search information on the current screen or application. For example, while in the **Contacts** tab, press **SEARCH** to search contact-related information such as names, phone numbers, or e-mail addresses in your contacts list.

Press **SEARCH** while in the Google Maps™ mapping service to search for places of interest. Press **SEARCH** while in the Home screen or Browser to launch Google Search™ and search information on the web.

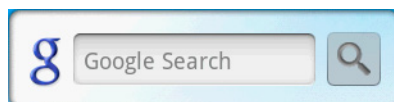

In any search bar, enter the information you want to search, then press **SEARCH** again, or touch . You can also use your voice to do a search.

MENU key

There is a **MENU** key (just to the left of **Z**), which you can use when the keyboard is open instead of pressing the **MENU** control button. This means, with the keyboard open, you can open the menu using your left hand (press the **MENU** key) and select a menu option with your right (roll and click the **TRACKBALL**).

ALT key

To type the characters shown in color on some of the keys, press the **ALT** key first, then press the key showing the special character. For example, if you need to type a double quote ("), press the **ALT** key, then press the "k" key [**ALT + k**].

- To type a series of special characters, lock the **ALT** key by pressing it twice. The cursor shape changes while the **ALT** key is locked: .
- Unlock the **ALT** key by pressing it once again.

SHIFT key

There are two **SHIFT** keys on your phone; one on the far left and the other on the far right of the lower row of keys. Press the **SHIFT** key while typing a letter to type the letter's capital. On number or symbol keys, pressing the **SHIFT** key causes the special character to appear.

- To type a series of characters in all caps, lock the **SHIFT** key by pressing it twice. The cursor shape changes while the **SHIFT** key is locked.
- Unlock the **SHIFT** key by pressing it once again.

@ key

When you type an email address, the "@" symbol separates the username from the domain; for example, username@domain.com. Use the **@** key (located in the bottom row of keys, just to the left of the **SPACEBAR**) to insert the @ symbol in an email address.

Typing and text navigation tips

Here are some typing and text navigation tips while you are entering text on a text entry field:

| | |
|--|---|
| Insert special character | ALT + SPACEBAR opens special character selector |
| Delete character to left | DEL |
| Delete the entire line | ALT + DEL |
| Persistent CAPS | Press SHIFT twice; press SHIFT again to escape |
| Jump cursor to beginning/ end of line | ALT + roll TRACKBALL left/right |
| Create tab character | ALT + q |
| Highlight text | Press and hold SHIFT while rolling the TRACKBALL |
| Deselect highlighted text | Roll TRACKBALL |
| Cut text | Highlight text, press MENU + x , or Highlight text, press and hold TRACKBALL , select Cut . |
| Copy text to the clipboard | Highlight text, press MENU + c , or Highlight text, press and hold TRACKBALL , select Copy |

| | |
|---|---|
| Paste text that you copied to clipboard | MENU + v , or Press and hold TRACKBALL , select Paste |
| Select all text in the text field | MENU + a , or Highlight text, press and hold TRACKBALL , select Select all |

Note While entering text on a text entry field, press and hold the **TRACKBALL** to open a menu where you can select to **Select All**, **Cut all**, **Copy All** text you have entered or **Paste** text that you have previously copied to the clipboard.

2.2 Using the Onscreen Keyboard

When you start a program or select a field that requires text or numbers, the onscreen keyboard becomes available.

Note You can only use the onscreen keyboard when the hardware keyboard is closed.

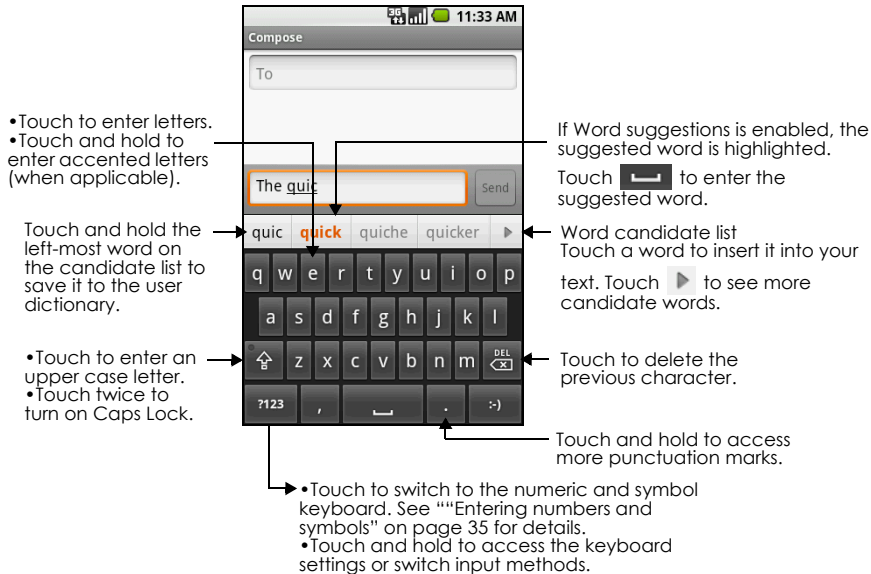

Tips

- When you do not need the keyboard, you can close it by pressing **BACK**. To show the keyboard again, touch a text box onscreen or when a text field is selected, press the **TRACKBALL**.
- If you need to insert or delete a character, use the **TRACKBALL** to position the cursor next to the character you want to edit.

Note The available keys on the keyboard will be different depending on the current text field selected. For example, in Browser, when you are in the URL field, some keys at the bottom row are replaced with alternate keys (for example, .com key) to make it faster for you to type web addresses.

Adjusting keyboard settings

Set onscreen keyboard options such as vibrate and/or emit a sound when you touch a key, auto-capitalization, auto-complete, and more.

To set onscreen keyboard options

- 1 Press **HOME**, then press **MENU**, and then touch **Settings > Locale & text > Android keyboard**.
- 2 Set the options you want to use for the onscreen keyboard.

Tip If you select the **Quick fixes**, **Show suggestions**, and **Auto-complete** options, the phone offers you smart word suggestions as you type, so you can enter text more quickly and accurately on the onscreen keyboard.

Using the landscape onscreen keyboard

When entering text, you can choose to use the landscape orientation of the onscreen keyboard, by turning the phone sideways, to use a larger keyboard that lets you type easily using two thumbs.

Note The **Orientation** check box in **HOME > MENU > Settings > Sound & display** needs to be selected for the screen orientation to automatically change.

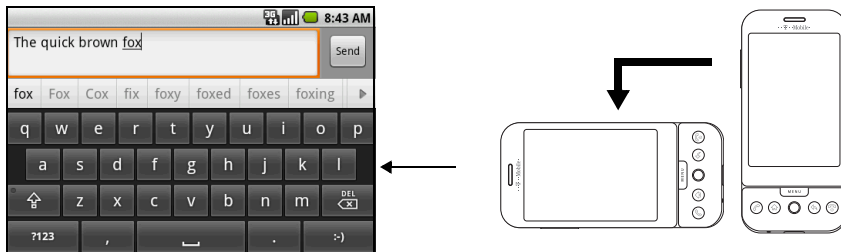

Entering numbers and symbols

Switch to the numeric and symbol onscreen keyboard to let you enter numbers and common symbols such as parentheses, braces, currency signs, punctuation marks, special characters, and more.

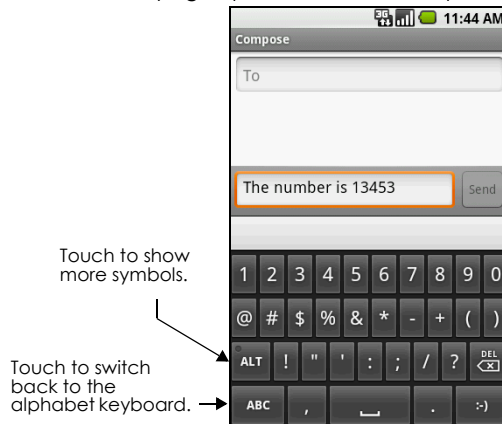

3 Using Phone Features and Managing Contacts

3.1 Making Calls

Use the Dialer to enter and call a phone number.

To open the Dialer

Do one of the following:

- On the Home screen, touch **Dialer**.
- On the Home screen, touch the Applications tab, then touch **Dialer**.
- While on any application screen, press the **CALL** button, then touch the **Dialer** tab.

To make a call on the Dialer

- 1 Touch the keys on the dialer to enter the phone number.

If you touch a wrong number, touch  to erase digits one by one. To

erase the entire number, touch and hold .

- 2 Press the **CALL** button to place the call.

Tip During a call, press the **VOLUME UP/DOWN** buttons on the left panel of the phone to adjust the in-call volume.

To make an emergency call

On the **Dialer** tab, enter the international emergency number for your locale (for example, 000), and then press the **CALL** button on your phone.

Notes

- When the screen is locked, you need to unlock it first before you can make an emergency call. If your phone is in sleep mode, press any button to wake up the phone and then press the **MENU** button to unlock the screen.
- Additional emergency numbers may be included in your SIM card. Contact your wireless service provider for details.

To make an international call

- 1 Touch and hold the number 0 key on the **Dialer** tab until the plus (+) sign appears. The plus (+) sign replaces the international prefix of the country that you are calling.
- 2 Enter the full phone number that you want to dial, and press the **CALL** button. The full phone number includes the country code, area code (without the leading zero, if any), and phone number.

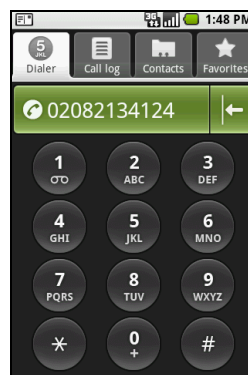

Make a call by speaking

You can make a phone call by opening the Voice Dialer and speaking.

- 1 Press and hold **CALL**, or press **HOME** and touch **Voice Dialer**.
- 2 Wait until you hear a tone and the Voice Dialer reports on the screen that it is "listening".
- 3 You can tell the **Voice Dialer** any of the following:
 - "Dial number", where number can be 3 digits (e.g., 911), 7 digits (e.g., 555-0123), or 10 digits (e.g., 205-555-0123). If you're speaking a phone number, then always say "Dial" before the number.
 - "Call name", where name is a contact stored on your phone in **Contacts**. If you're speaking a name, then always say "Call" before the name.
 - "Call voicemail" to dial your voicemail number.
 - "Redial" to dial the last outgoing call.
- 4 Regardless of what you tell the **Voice Dialer**, you will be asked to confirm your choice from a menu. If you spoke a name with more than one match in **Contacts**, or if you've stored more than one number for the contact, you'll be asked to select the number.

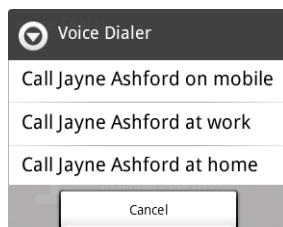

Tip You can always cancel the call at this point by selecting **Cancel** on the dialog box.

- 5 Once you select or confirm your choice, your call is placed.

Make a call from the Call log

While on any application screen, press the **CALL** button to directly access the **Call log** tab. You can then touch a missed call, dialed number, or received call that you want to call back.

For more information about the **Call log** tab, refer to "Using the Call Log" on page 41.

Add and call your contacts

Add the phone numbers of your contacts so you can call them more easily.

- 1 While on any application screen, press the **CALL** button, and then touch the **Contacts** tab. "Creating and Managing Your Contacts" on page 43 describes how to add contacts to this tab.
- 2 Do one of the following:
 - Touch a contact to access the contact details. Then touch the number you want to call.
 - Touch and hold the contact you want to call and then from the options menu, touch **Call Mobile**, **Call Work**, or **Call Home**.

Add and call favorite contacts

To quickly find and call contacts who you most frequently communicate with, you can add them in the **Favorites** tab.

- 1 While on any application screen, press the **CALL** button, and then touch the **Favorites** tab.
- 2 You need to have at least one favorite contact to make a call from this tab. See "Add favorite contacts" on page 45 for the instructions.
- 3 Do one of the following:
 - Touch a favorite contact to access the contact details. Navigate to the Dial number section, then touch a phone number that you want to call.
 - Touch and hold the favorite contact you want to call and then from the options menu, touch **Call Mobile**, **Call Work**, or **Call Home** to make the call.

Call voicemail

The voicemail icon  appears in the status bar when you have a new voicemail.

To call voicemail

- 1 Touch and hold the status bar, then slide your finger downward on the screen to open the Notifications panel.
- 2 Touch **New voicemail** to listen to your voicemail.

To use the Dialer to call voicemail

- 1 Press the **CALL** button, then touch the **Dialer** tab.
- 2 Touch and hold the number 1 key .

Note If you have not set up your voicemail number, a missing voicemail number error message appears on the screen when you touch and hold the number 1 key. For more information on how to set up your voicemail number, refer to "Adjusting Phone Settings" on page 43.

3.2 Answering or Rejecting Calls

When you receive a phone call from someone in Contacts, the Incoming call screen appears and displays the caller's caller ID icon, name, and phone number. When you receive a call from someone who is not stored in Contacts, only the default caller ID icon and phone number appear.

To answer a call

Press the **CALL** button.

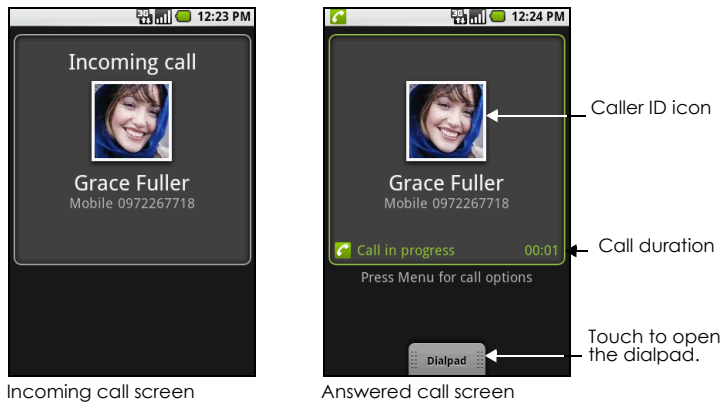

To reject a call

Press the **END CALL/POWER** button to reject a call and redirect the caller to your voicemail.

3.3 Call Options

When a call is in progress, press **MENU** to open the call options. Touch a button to put a call on hold, dial another contact for a phone conference, mute the phone microphone, and more.

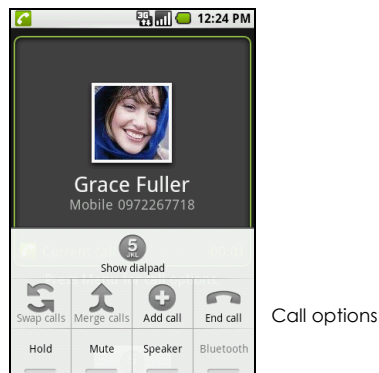

Note When the phone is dialing, only the **End call** and **Speaker** buttons are enabled.

To hold the call

Press **MENU**, then touch **Hold** to hold the call. Touch this button again to resume the call. When you hold the call, the Hold call icon  appears in the status bar.

To mute the microphone during a call

Press **MENU**, then touch **Mute** to turn the microphone on or off. When the microphone is turned off, the Mute button indicator lights up green and the mute icon  appears in the status bar.

Note If you are using the provided wired headset in a call, you can press the button on the wired headset to mute the microphone. Press the button again to unmute the microphone.

To turn the speakerphone on or off

During a call, press **MENU**, then touch **Speaker** to turn the speakerphone on or off. The Speaker button indicator lights up green and the speakerphone icon  appears in the status bar when the speakerphone is on.

Warning! To avoid damage to your hearing, do not hold your phone against your ear when the speakerphone is turned on.

To transfer the call to a Bluetooth headset

When a Bluetooth headset is paired and connected to your phone, you can receive all incoming calls on the Bluetooth headset for hands-free conversation.

Tip Press **MENU**, then touch **Bluetooth** to toggle between the phone speaker and the paired Bluetooth headset.

Note For more information on how to connect a Bluetooth headset or a Bluetooth car kit to your phone, refer to "Using Bluetooth" on page 74.

When the Bluetooth headset is disconnected from your phone, do the following to reconnect it and transfer the current call:

- 1 Make sure that Bluetooth on your phone and the Bluetooth headset are on. Refer to "Using Bluetooth" on page 74 for details.
- 2 During a call, press **HOME** > **MENU**, then touch **Settings**.
- 3 Touch **Wireless controls** > **Bluetooth settings**.
- 4 In the **Bluetooth devices** section, touch and hold the name of the Bluetooth headset that you have previously paired and connected to your phone, then touch **Connect** on the options menu. When connected, the Bluetooth connected icon  appears in the status bar. The call is automatically transferred to the Bluetooth headset.
- 5 Press the **TALK** button to display the current call screen.
- 6 To transfer the call back to your phone, on the ongoing call screen, press **MENU**, then touch **Bluetooth**.

To end a call

When a call is in progress, you can do one of the following to hang up:

- Press the **END CALL/POWER** button.
- Press **MENU**, then touch **End call**.
- If you are using the provided wired headset, press and hold the button to end the call.

Manage multiple calls

Your phone notifies you when you have another incoming call, and gives you the option of rejecting or accepting the call. If you are already on a call and accept the new call, you can choose to swap between the two callers.

- Press the **CALL** button to take the second call, and put the first call on hold. You can also press **MENU** and then touch **Hold call in progress & answer**.
- To end the second call and return to the first call, press the **END CALL/POWER** button on your phone.
- To end the first call and take the incoming call, press **MENU**, then touch **End call in progress & answer**.
- To swap between two calls, press **MENU** and then touch **Swap calls**.

Set up a conference call

You can set up a conference call with as many as six participants, including yourself.

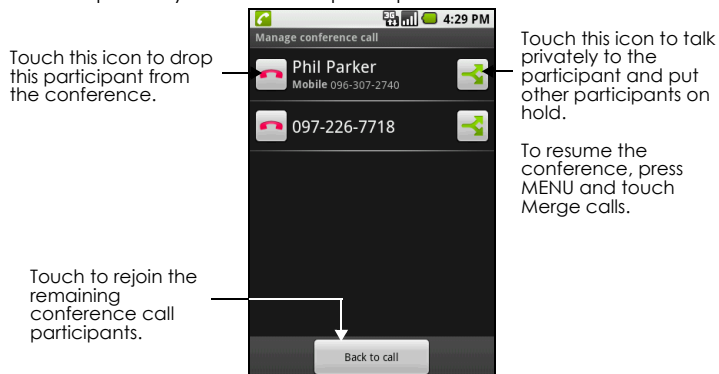

Note Not all mobile phone networks support conference calling. Contact your wireless service provider for details.

- 1 Make a call to the first conference call participant. See "Making Calls" on page 36 for details.
- 2 When connected to the first participant, press **MENU** and then touch **Add call**.
- 3 Enter the phone number of the person you want to add to the conference call and press the **CALL** button. Or touch the **Call log**, **Contacts**, or **Favorites** tab and then select the next conference call participant from the list.
The first call is automatically put on hold.
- 4 When connected to the second conference call participant, press **MENU**, then touch **Merge calls** to begin the conference call.
- 5 To add more conference call participants, repeat steps 2 and 3.
- 6 During a conference call, press **MENU** and touch **Manage conference** to drop a conference call participant or to talk privately to one of the participants.



- 7 To end the conference call and disconnect all callers, press the **END CALL/POWER** button.

3.4 Using the Call Log

The **Call log** tab lists all missed calls , dialed numbers , and received calls .

To use the Call log tab

- 1 While on any screen, press the **CALL** button, then touch the **Call log** tab.
- 2 Do one of the following:
 - Touch a name or number in the list to open a screen that gives you options on what you can do with the contact.
 - Touch and hold a name or number in the list to display the options menu where you can call the contact, view the contact information (if the number is stored in your contacts list), edit the number before you redial, and more.

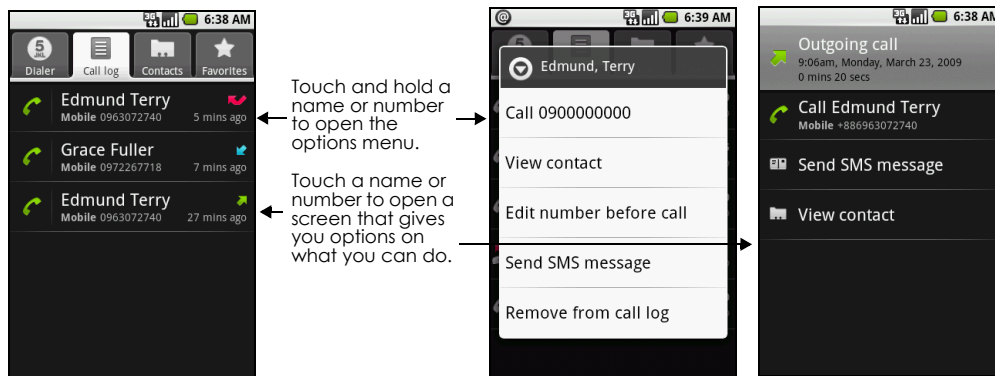

To add a new phone number to Contacts

If the phone number of a person who called is not in your contacts list, you can choose to save the number after you hang up.

- 1 While on any screen, press the **CALL** button, then touch the **Call log** tab.
- 2 Touch and hold the received call that you want to save to your contacts list. Then touch **Add to contacts**.
- 3 When the Contacts screen appears, touch **Create new contact**. The received call number is automatically added to the **Mobile** phone field in the **Phone numbers** section.
- 4 Enter other information for the contact, if desired.
- 5 Scroll down the screen, then touch **Done**.

Note For more information about creating contacts, refer to "Add a new contact" on page 44.

To check a missed call

You will see the missed call icon  in the status bar when you missed a call. To check who the caller was, press the **CALL** button, then touch the **Call log** tab.

Tip You can also touch and hold the status bar, then slide your finger downward on the screen to open the Notifications panel. The missed call number and/or contact name is displayed.

To clear the Call log

Do one of the following when viewing the **Call log**:

- To remove a name or number, touch and hold on the name or number, then touch **Remove from call log**.
- To clear the entire Call log, press **MENU** then touch **Clear call log**.

3.5 Adjusting Phone Settings

You can adjust the phone settings of your phone such as your voicemail number, or enable additional call services from your wireless service provider.

To open the **Call settings** screen, press **HOME > MENU**, then touch **Settings > Call settings**.

| Options | Description |
|---------------------------------|---|
| Fixed Dialing Numbers | Restrict outgoing calls to a fixed set of numbers. To enable this feature you must know your SIM card's PIN2 code. If this feature is supported, obtain your PIN2 code from your wireless service provider. |
| Voicemail | Specify another voicemail number aside from the voicemail number on your SIM card. |
| Call forwarding | Select how you want your phone to handle busy, unanswered, and unreachable calls. You can also set the call forwarding option for all incoming calls. |
| Additional call settings | Enable or disable caller ID and call waiting services. |
| Network operators | Scan and select a network operator manually, or set the network selection to automatic. |

3.6 Turning the Phone Function On and Off

In many countries, you are required by law to turn off the phone while on board an aircraft. A way to turn off the phone function is to switch your phone to **Airplane mode**. In Airplane mode, all wireless radios on your phone are turned off, including the phone function, Bluetooth, and Wi-Fi.

To enable or disable Airplane mode

- 1 Press **HOME**, then press **MENU**, and then touch **Settings > Wireless controls**.
- 2 Touch **Airplane mode** to enable or disable it. When enabled, the Airplane mode icon  is displayed in the status bar.

Tip When you disable Airplane Mode, the phone function is turned back on and the previous state of Bluetooth and Wi-Fi is restored.

3.7 Creating and Managing Your Contacts

Similar to an online address book, the Contacts application gives you quick and easy access to the people you want to reach. You can view and create contacts on your phone and sync these with your Google Mail contacts on the web. You can also import contacts stored on your SIM card.

To view your Contacts list

Do one of the following to display your contacts list:

- Press **HOME**, then touch **Contacts**.
- Press the **CALL** button, then touch the **Contacts** tab.

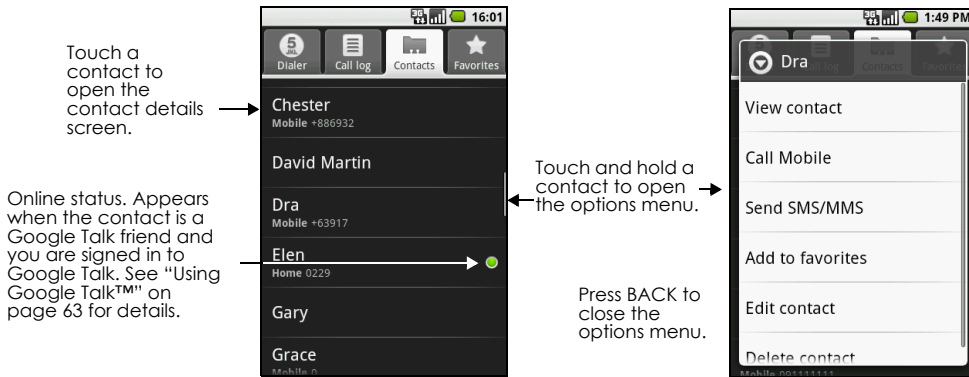

Tip When you reply to or forward an email message to an email address that is not in Contacts, the email address is automatically added to your contacts list.

Add a new contact

To add a new contact

- 1 In the contacts list, press **MENU**, then touch **New contact**.
- 2 Enter the contact's name and other contact information such as their mobile phone number, home phone number, or email address. Slide your finger up or down to see more labels.

Note To change a default information label, for example Home email to Work email, touch the information label button, then select another label on the menu. You can also touch **Custom** on the menu to create another information label that is not in the list.

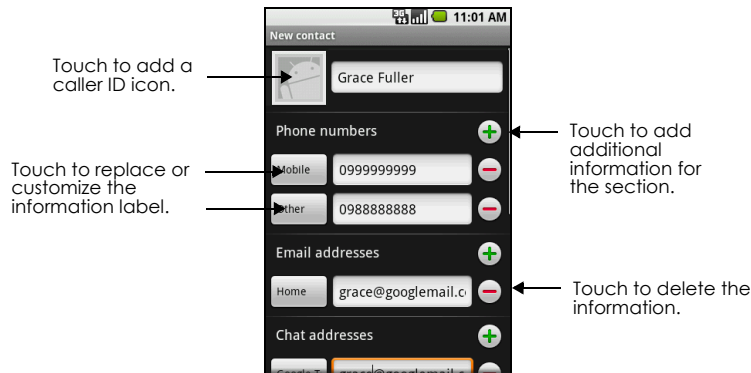

Note If you want all calls from this contact to go directly to your voicemail, select the **Incoming calls** check box.

- 3 When finished, press **MENU** and then touch **Done**.

To import contacts from the SIM card

You can add contacts saved on your SIM card to your phone's contacts list.

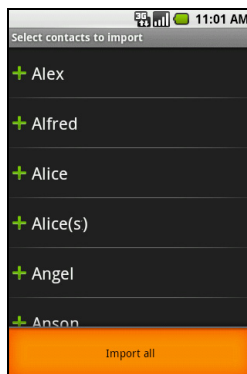

- 1 In the contacts list, press **MENU**, then touch **Import contacts**.
- 2 Do one of the following:
 - To import a single contact, touch the contact you want to import. Add or edit contact details, then touch **Done**.
 - To import all contacts, press **MENU**, then touch **Import all**.

Add favorite contacts

Use the **Favorites** tab as a way to filter your contacts list.

- 1 In the contacts list, press and hold a contact to open the options menu.
- 2 Touch **Add to favorites**.

The contact will be added to the contacts list on the **Favorites** tab. A colored star will also appear with the contact name in the contact details screen.

To view favorite contacts

Press **CALL** and then touch the **Favorites** tab. You can also see your frequently called contacts or numbers on the **Favorites** tab.

To remove a contact from the Favorites tab

On the **Favorites** tab, touch and hold the contact you want to remove and then touch **Remove from favorites** on the options menu.

Edit and customize your contacts

To edit contact information

You can always make changes to the information you have stored for a contact.

- 1 In the contacts list, touch and hold the contact whose information you want to edit, then touch **Edit contact**.
- 2 Edit the contact information, then touch **Save**. To ignore all changes you made, touch **Discard changes**.

To change the contact's default phone number

The default phone number of a contact appears below the contact's name in the contacts list. The default phone number is used when you initiate a call or send a text message from the contacts list (by touching and holding a contact). You can change the contact's default phone number.

- 1 In the contacts list, touch the contact to open the contact details screen.
- 2 Touch and hold the phone number you want to use as the contact's default phone number, then touch **Make default number**. The default phone number moves on top of the list and appears after the phone number.
- 3 Press **BACK** when you are done.

Communicate with your contacts

From the contacts list you can quickly call or send a text or multimedia message to a contact's default phone number.

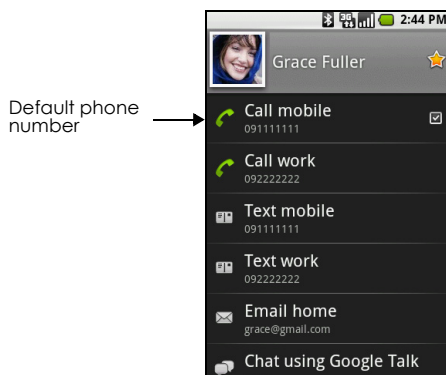

However, to view all the information you have stored for a contact, and to initiate other types of communication with that contact, open the contact details screen.

To open the contact's details screen, touch the contact name in the contacts list.

To call a contact

Do one of the following:

- In the contacts list, use the **TRACKBALL** to navigate to the contact you want to call, then press the **CALL** button. The contact's default phone number is dialed.
- To dial a different number for the contact, touch the contact's name in the contacts list to open the contact details screen, then touch a phone number.

To send a text or multimedia message to a contact

The contact must have a mobile phone number in their contact details for you to send them a text or multimedia message.

Do one of the following:

- When the contact's default number is a mobile phone number, touch and hold the contact's name in the list, then touch **Send SMS/MMS** on the options menu.
- Touch the contact in the list to open the contact details screen, then touch **Text mobile**, **Text work**, or another text option.

A compose screen opens for your message.

Note For more information about composing and sending text and multimedia messages, refer to "Exchanging Messages" on page 52.

To send an email to a contact

The contact must have an email address in their contact details for you to send them an email.

- 1 In the contacts list, touch the contact you want to send the email to.
- 2 When the contact details screen opens, touch **Email home**, **Email work**, or another email option. A compose screen opens for your new email.

Note If you have more than one email account set up on your phone, you will be prompted to select which account to use to send the message.

Note For more information about composing and sending email messages, refer to "Exchanging Messages" on page 52.

4 Managing Your Time

4.1 Using Calendar

Use Calendar to create and manage events, meetings, and appointments. Depending on your synchronization settings, the Calendar on your phone stays in sync with your Calendar on the web.

Note For more information about Calendar synchronization, refer to "Synchronizing Google Applications™" on page 104.

Open Calendar

- 1 Press **HOME**, then touch the Applications tab to open it.
- 2 Touch **Calendar**.

Create events

To create an event

- 1 On any Calendar view, press **MENU** and then touch **New event** to open the Event details screen.
- 2 Enter the event name using the keyboard.
- 3 Do one of the following:
 - If there is a time frame for the event, touch the **From** and **To** date and time to set them.
 - If it is a special occasion such as a birthday or a whole-day event, set the **From** and **To** date, then select the **All Day** check box.
- 4 Enter the event location and description.
- 5 If you have more than one calendar, select the **Calendar** where you want to save the event.

Note You can create multiple calendars, such as Personal, Business, or Family, using Calendar on the web. Depending on your synchronization settings, these calendars are added to your phone when you synchronize the Calendar. For more information on how to create calendars, go to <http://www.google.com/support/calendar>.

- 6 Set the event reminder time in **Reminders**, then select whether the event is recurring in **Repetition**.
- 7 When finished, touch **Save**.

Tip To quickly create an event in Day, Week, or Month view, touch and hold an empty time slot, then touch **New event**. A new Event details screen appears with the selected time slot and date in the **From** and **To** fields.

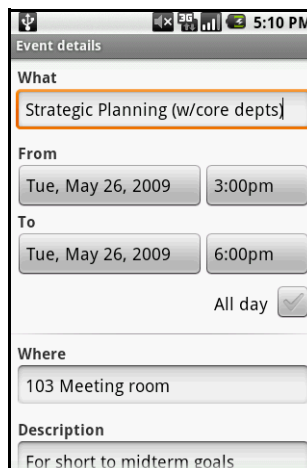

Calendar views

You can display the Calendar in daily, weekly, monthly, or agenda view. To change the Calendar view, press **MENU**, then touch **Day**, **Week**, **Month**, or **Agenda** (current view is not in the menu.)

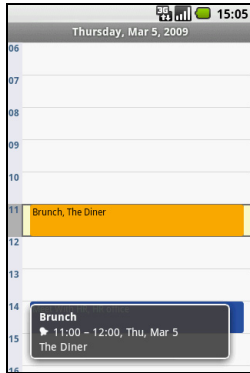

Day view

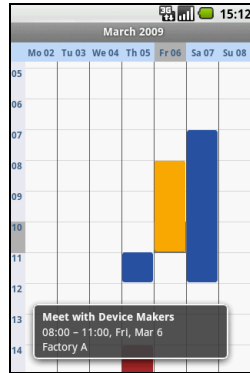

Week view

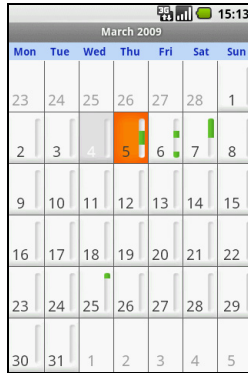

Month view

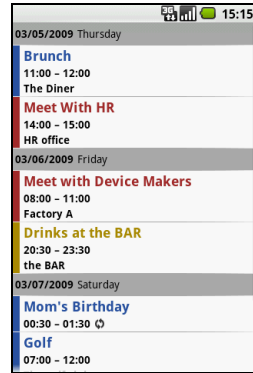

Agenda view

While in a calendar view you can:

- To quickly view an event's details while in **Day** or **Week** view, touch it or highlight it using the **TRACKBALL**. A quick view window appears on the lower part of the screen.
- Touch the quick view window to view details about the event.
- Touch and hold an event to open a window with options for viewing, editing, or deleting that event, or creating a new event.

Event reminders

If you set a reminder for an event, the upcoming event icon  appears in the notifications area of the status bar, when the reminder time arrives.

To view, dismiss, or snooze a reminder

- 1 Touch the status bar, then slide your finger down the screen to open the Notifications panel.
- 2 Touch the upcoming event name to display the event.
Note If you have other pending event reminders, these events will also appear on the screen.
- 3 Do one of the following:
 - Touch **Snooze all** to snooze all event reminders for five minutes.
 - Touch **Dismiss all** to dismiss all event reminders.
 - Press **BACK** to keep the reminders pending in the notifications area of the status bar.

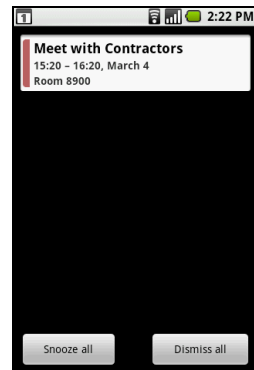

Synchronize Microsoft® Office Outlook® calendar

You can synchronize Outlook calendar on your computer with Calendar on the web. Since Calendar on your phone can automatically synchronize with Calendar, you can access your Outlook calendar appointments and events on your phone anytime.

To learn how to synchronize, go to <http://www.google.com/support/calendar>.

4.2 Using Alarm Clock

Use your phone as an alarm clock. Alarm Clock lets you set an unlimited number of alarms.

To open Alarm Clock

Press **HOME**, then touch the Applications tab and then touch **Alarm Clock**.

When you open Alarm Clock for the first time, three alarms are set up by default, ready for you to customize. All three alarms are turned off by default.

Set an alarm

- 1 Touch one of the available alarms.
- 2 Touch **Time** to set the alarm time. Adjust the time by touching **+** or **-**. Touch **AM** to change to **PM** or vice versa, then touch **Set** when finished.

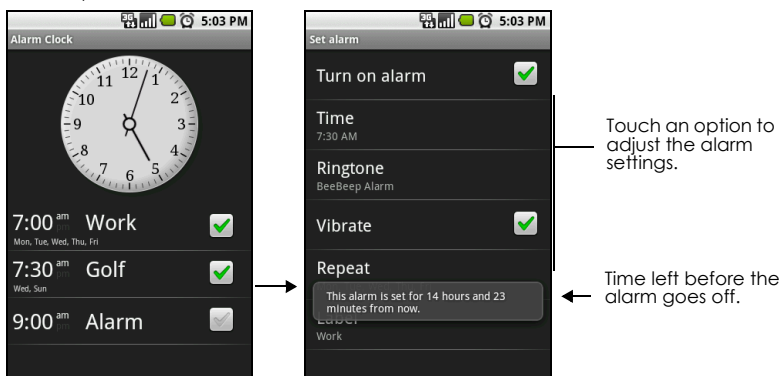

- 3 Touch **Ringtone**, then select the alarm ring tone. The ring tone plays when selected.
Note Touch **Vibrate** if you want the phone to also vibrate when the alarm goes off.
- 4 Touch **Repeat** to select the days you want the alarm to sound, then touch **OK**.
Note If you do not select any days for the alarm, the word **Never** will show which means that your alarm will only go off once.
- 5 Touch **Label** to set a name for the alarm.
- 6 Press **BACK** to return to the Alarm Clock screen.

Note If you need to set more than 3 alarms, you can add more alarms while on the Alarm Clock screen by pressing **MENU** and then touching **Add alarm**.

You can temporarily disable an alarm by clearing the check box (by touching it) of the alarm on the Alarm Clock screen.

Customize Alarm Clock

You can change the appearance of the clock displayed on the Alarm Clock screen.

- 1 On the Alarm Clock screen, touch the clock with your finger to open the clock selection screen. Available clock displays appear at the bottom of the screen.
- 2 Slide your finger left or right on top of the clock displays to view them.
- 3 Touch the clock display you want.
Note To hide the clock display, on the Alarm Clock screen, press **MENU**, then touch **Hide clock**.

Note To change the date and time format displayed in your alarms, refer to "Set the date, time zone, and time" on page 100.

Delete an alarm

- 1 On the Alarm Clock screen, Touch the alarm you want to delete.
- 2 On the Set alarm screen, press **MENU** and then touch **Delete alarm**.

Silence all alarms

You can set whether alarms sound even when your phone is in Silent mode.

- 1 On the Alarm Clock screen, press **MENU** and then touch **Settings**.
- 2 Touch **Alarm in silent mode** to set whether alarms play when the phone is otherwise in silent mode.
- 3 When you are done, press **BACK**.

5 Exchanging Messages

5.1 Sending Text and Multimedia Messages

Messaging lets you compose and send text (SMS) and multimedia messages (MMS) to other mobile phones.

If the list of messages does not fit on the screen, you can scroll up the screen to view more messages, or roll the TRACKBALL down.

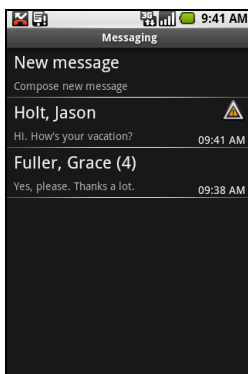

← Touch to create a new text or multimedia message.

← Message delivery status.

← Touch to open the message or message thread and read the text or view the multimedia message.

Open Messaging

Press **HOME**, then touch the Applications tab, and then touch **Messaging**. The message list appears.

Create and send SMS and MMS messages

You can compose text (SMS) messages of up to 160 characters. If you continue to type after the limit is reached, your message will be delivered as one, but count as more than one message. These are called concatenated messages.

Multimedia messages, also known as MMS, can contain text and a picture, a recorded voice, an audio file, or a picture slideshow.

Note Messaging automatically converts a text message into a multimedia message when you entered an email address in the **To** field, added a message subject, or attached an item.

To create and send a text message

- 1 On the Messaging screen, touch **New message**. The Compose screen opens.
- 2 Enter the mobile phone number of the message recipient in the **To** field. As you enter the phone number, matching contacts will appear on the screen. Touch a recipient or continue entering the recipient's phone number.

Enter a name to look up a contact or touch **7123** to enter a phone number.

Touch to automatically enter the mobile phone number of the matched contact. Note: The phone number only appears if the number was filed under Mobile in Contacts.

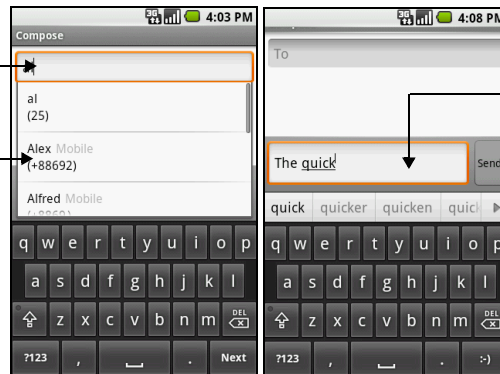

Enter your text message here.

Touch to send the message.



Touch to insert a smiley face. Touch and hold to open a menu where you can choose a different smiley to insert into the message.

- 3 Touch the text box that contains the text **"Type to compose"**, then start composing your message.
Note As you near the 160-character limit, a counter will appear in the top right corner of the text box to tell you how much characters are left. Once you go over that limit, a new message is created but automatically joined into one when received.
- 4 When done, touch **Send** to send the text message. The send progress is displayed at the right side of the message in the message thread or in the message list.

Note To receive delivery reports and know when a text message is received, in the message list, press **MENU** and then touch **Settings**. In the SMS settings section, select the **Delivery reports** check box.

To create and send a multimedia (MMS) message

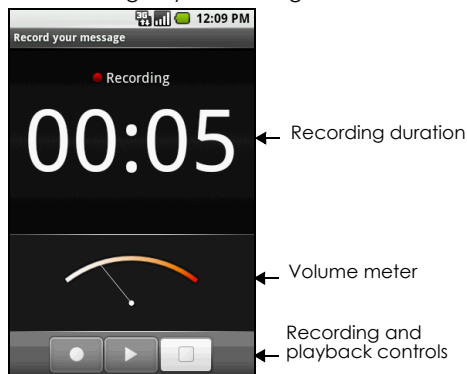

- 1 On the Messaging screen, touch **New message**. The Compose screen opens.
- 2 Enter the mobile phone number or email address of your message recipients in the **To** field. As you enter the phone number or email address, matching contacts will appear on the screen. Touch a recipient or continue entering the recipient's phone number or email address.
Tip You can add a subject line by pressing **MENU** and then touching **Add subject**.
- 3 Touch the text box that contains the text **"Type to compose"**, then start composing your message.
Note As you near the 160-character limit, a counter will appear in the top right corner of the text box to let you know how many characters you can still enter before you reach the limit for one message.
- 4 Press **MENU** and then touch **Attach**.
- 5 On the Attach window, select from the following file attachments:
 - **Pictures**. Opens the Gallery application. Touch a picture on the screen to attach it to your message.
 - **Capture picture**. Opens the Camera application. Take a picture of your subject, then touch **Attach** to attach it to your message. For more information about the Camera application, refer to "Using Camera and Camcorder" on page 84.
 - **Videos**. Opens the Gallery application. Touch a video on the screen to attach it to your message.
 - **Capture video**. Opens the Camcorder application. Take a video, then touch **Attach** to attach it to your message. For more information about the Video application, refer to "Using Camera and Camcorder" on page 84.
 - **Audio**. Opens the Select audio menu. Touch an audio file to select, then touch **OK** to attach the file into your message.

- **Record audio.** Touch to open the message recorder. Touch  to start recording your message, then touch  to stop. To listen to your recording, touch . Touch **Use this recording** to attach the recording to your message.

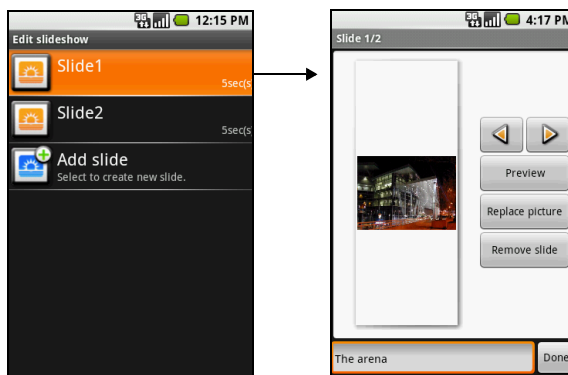

- **Slideshow.** Touch to open the Edit slideshow screen. Touch **Add slide** to create a new slide. Touch the created slide (for example, Slide 1), touch **Add picture**, then select the picture you want to add to the slide. You can also navigate to the text box and enter a caption for the picture. Press **MENU** to preview the slide, remove the picture, add a music, add another slide, or change the slide duration or layout. When finished, touch **Done** to attach the slideshow to your message.



Tip You can create a slideshow of up to ten slides. When editing multiple slides, touch  to edit the next slide or touch  to return to the previous slide.

Notes

- To view the slideshow, touch the **Preview** button while editing the slideshow, or touch the **Play** button on the Compose screen.
- To remove or replace a picture or an audio attachment, on the Compose screen, touch the **Remove** button beside the attachment. To remove a slideshow attachment, on the Compose screen, touch **Edit**, press **MENU**, then touch **Discard slideshow**.

6 When you are finished composing the multimedia message, touch Send. The send progress is displayed at the right side of the message in the message thread or in the message list.

Note To receive delivery reports and know when a picture message is received, in the message list, press **MENU**, then touch **Settings**. Select the **Delivery reports** check box below the MMS settings section.

To save a message as a draft

While composing a text or multimedia message, press **BACK** to automatically save your message as a draft. To resume composing the message, touch the message in the message list. Continue editing the message, then touch **Send** to send it.

Receive text and multimedia messages

Depending on your notification settings, the phone will play a ring tone, vibrate, or display the message briefly in the status bar when you receive a new text or multimedia message. To change the notification for new text and multimedia messages, refer to "Adjust text and multimedia message settings" on page 57.

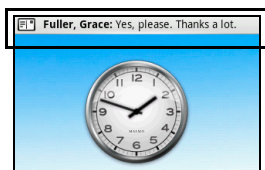

A new message icon  also appears in the notifications area of the status bar to notify you of a new text or multimedia message. To open the message, refer to the next section.

Manage messages and message threads

Text and multimedia messages that are sent to and received from a contact (or a number) are grouped into conversations or message threads. Threaded text or multimedia messages let you see exchanged messages (similar to a chat program) with a contact on the screen. Message threads are listed in order of when you received them, with the latest message on top of the thread.

To open and read a text message

Do one of the following:

- Press **HOME**, then touch and hold the status bar, and then slide it down to open the Notifications panel. Touch the new message to open and read it.
- On the message list, touch the text message or message thread to open and read it.

To return to the message list from a text message thread, press **MENU** and then touch **All threads**.

Notes

- To view the details of a particular message, in the message thread, touch and hold the message to open the options menu, then touch **View message details**.
- If a message contains a link to a web page, touch the link to open Browser and view the web page.
- If a message contains a phone number, touch the message to open Dialer so you can call the number.

To open and view a multimedia message

- 1 In the message list, touch a multimedia message or message thread to open it.
- 2 Touch the **Play** button at the right side of a multimedia message to view it.

Tip You can save the file attachment on the multimedia message to the SD card. To save, touch and hold the file and then touch **Copy attached to SD card** on the options menu.

Notes

- When **Auto-retrieve** in MMS settings is disabled, only the message header is downloaded. To download the entire message, touch the **Download** button at the right side of the message. Once the message has downloaded, touch the **Play** button to view the message. For details, refer to "Adjust text and multimedia message settings" on page 57.
- If you are concerned about the size of your data downloads, check the multimedia message size before you download it.

To reply to a text or multimedia message

- 1 In the message list, touch a text or multimedia message thread to open it.
- 2 Use the **TRACKBALL** to navigate to the text box at bottom of the screen, enter your reply message, and then touch **Send**.

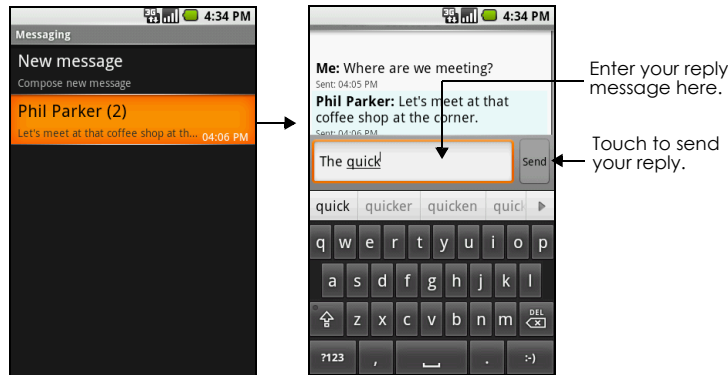

Tip To reply a text message with a multimedia message, open the text message, press **MENU** and then touch **Add subject**, or **Attach**. The text message is automatically converted into a multimedia message.

To delete a message or a message thread

- 1 In the message list, touch the message thread that you want to delete.
- 2 Do one of the following:
 - To delete the entire thread, press **MENU** and then touch **Delete thread**. When prompted to confirm, touch **OK**.
 - To delete a message in a thread, touch and hold the message that you want to delete, then touch **Delete message** on the options menu. When prompted to confirm, touch **OK**.

Note To delete all messages on the message list, press **MENU** on the message list and then touch **Delete threads**.

Adjust text and multimedia message settings

In the message list, press **MENU** and then touch **Settings** to adjust the text or multimedia message settings. You can set the following options:

SMS settings

Delivery reports Select this option to receive a report on the delivery status of your message.

Manager SIM card messages Touch to view text messages stored on your SIM card. You can also delete or copy these messages to your phone's memory.

MMS settings

Delivery reports Select this option to receive a report on the delivery status of your message.

Read reports Select this option if you want to receive a report whether each recipient has read or has deleted the message without reading it.

Auto-retrieve Select this option to automatically retrieve all your MMS messages completely. When selected, the MMS message header plus the message body and attachments will automatically download to your phone. If you clear this check box, only the MMS message header will be retrieved and shown in your message list.

Roaming auto-retrieve Clear this option if you only want the MMS message headers to download while roaming. Select this option to automatically download your complete multimedia messages even while roaming.

Notification settings

Notifications Select this option if you want to receive a notification in the status bar when a new text or multimedia message arrives.

Select ringtone If you want the phone to ring when a new message arrives, touch this option, then select a ring tone that is specific to new text and multimedia messages. Note that the ring tone briefly plays when selected.

Vibrate Select this option if you want the phone to vibrate when a new text or multimedia message arrives.

5.2 Using Google Mail™

Google Mail is Google's web-based email service. Google Mail is configured when you first set up your phone. Depending on your synchronization settings, Google Mail on your phone is automatically synchronized with your Google Mail account on the web. For more information about synchronization, see "Synchronizing Google Applications™" on page 104.

To open Google Mail

Press **HOME**, then touch the Applications tab, and then touch **Gmail**.

Folder (or Label) and number of unread email messages.

Checked email. Select one or more emails to apply an action. Note: Batch operations needs to be enabled.

To scroll through the message list: Slide your finger up/down on the screen. Roll the TRACKBALL up/down.

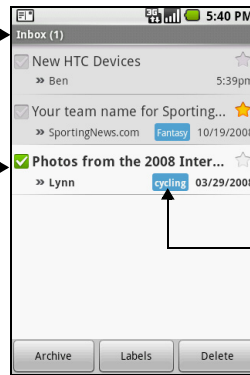

Starred email. Touch and hold a message to open a menu where you can add or remove the star.

Unread messages are displayed in bold.

Message label

Actions for checked email(s). This will not show if there is no item selected in the inbox.

The Inbox conversations list (hereinafter referred to as Inbox) is your default Google Mail view. All your received emails are delivered to your Inbox.

Tip If you rarely perform actions on batches of conversations (that is, multiple conversations that you check in the left column), you can hide checkmarks in conversation lists by pressing **MENU**, touching **Settings**, and unselecting **Batch operations**.

To refresh Google Mail

Press **MENU** and then touch **Refresh** to send or receive new emails and to synchronize your emails with your Google Mail account on the web.

Create and send emails

To create and send an email

- 1 In the Inbox, press **MENU** and then touch **Compose**.
- 2 Enter the message recipient's email address in the **To** field. If you are sending the email to several recipients, separate the email addresses with a comma. You can add as many message recipients as you want.

Note If you want to send a carbon copy (Cc) or a blind carbon copy (Bcc) of the email to other recipients, press **MENU** and then touch **Add Cc/Bcc**.

- 3 Enter the email subject, then compose your email.

Tip If you want to add a picture attachment, press **MENU**, touch **Attach**, and then touch the picture you want to attach.

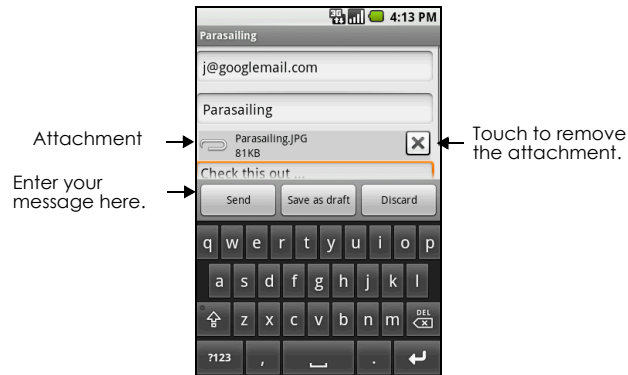

4 After composing your email, touch **Send**.

Note While composing the message, touch **Save as draft** to save it as a draft. To view your draft email messages, in the Inbox, press **MENU** and then touch **View labels > Drafts**.

To add a signature to emails

You can add a signature to email messages that you send.

1 In the Inbox, press **MENU** and then touch **Settings > Signature**.

2 Enter your signature in the text box, then touch **OK**.

Tip You can create a signature consisting of multiple lines of text. At the end of each line of text,

touch  on the onscreen keyboard to create another line.

To view your sent messages

In the Inbox, press **MENU** and then touch **View labels > Sent**.

Receive and read emails

Depending on your notification settings, the phone plays a ring tone, vibrates, or displays the email message briefly in the status bar when you receive a new email. A new email message  icon also appears on the notifications area of the status bar to notify you of a new email.

Note For more information on email notification settings, refer to "Set Google Mail settings" on page 61.

Google Mail groups messages with their responses. This conversation list continues to grow as new replies arrive, so you can always see your messages in context. Conversations are also referred to as message threads. A new message or a change to the subject of a current message will begin a new thread.

To view emails

Do one of the following:

- Press **HOME**, then touch and hold the status bar, and then slide down your finger on the screen to open the Notifications panel. Touch the new email to view it.
- While in the Inbox, touch the unread email or the conversation with the unread email to view it.

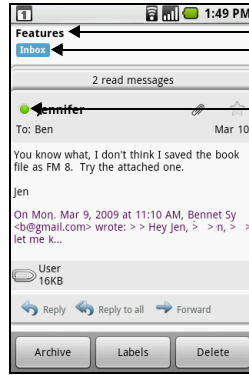

Message subject
Message label

Online status.
Appears when the contact is a Google Talk friend and you are signed in to Google Talk.

To scroll through the message:
1. Slide your finger up/down on the screen.
2. Roll the TRACKBALL up/down.

If the sender of a message is a friend who uses Google Talk, the friend's status (available, busy, and so on) is indicated by the colored icon to the left of the friend's name.

To search for email messages

You can search for a specific email message by sender, by subject, by label, and by using the advanced search options described on the Google Mail web site. Your searches cover all the email in your Google Mail account on the web, not just the email you have downloaded to your phone.

- 1 In the Inbox, press **MENU** and then touch **Search**.
- 2 Enter the search keyword in the box, then touch **Search**.

Reply to or forward emails

- 1 In the message thread, scroll down to the end of the conversation.
- 2 Touch **Reply**, **Reply to all**, or **Forward**.
- 3 Do one of the following:
 - If you selected **Reply** or **Reply all**, enter your reply message.
 - If you selected **Forward**, specify the message recipients.
- 4 Touch **Send**.

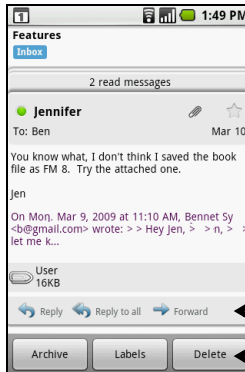

Message options

Thread options

Manage conversations and emails

Conversations

In the Inbox, touch and hold the conversation, then touch:

- **Read** to return to the message.
- **Archive** to archive the email message.
Tip To display your archived messages, in the Inbox, press **MENU**, then touch **View labels > All Mail**.
- **Mute** to mute the entire conversation.
Tip If you're part of a long message conversation that isn't relevant, you can 'mute' the conversation to keep all future additions out of your inbox.
- **Mark read** or **Mark unread** as desired. Unread messages or threads with unread messages display in bold in the Inbox.
- **Delete** to delete the email message.
- **Add star** or **Remove star** to assign a star or remove the star on the conversation.
- **Change labels** to add or change the label of the conversation.
Note You cannot use the phone to create labels; do that on the Google Mail web site.
- **Report spam** to report the conversation as spam.

Email messages

In the message thread, navigate to the email header or message using the **TRACKBALL**, press **MENU** and then touch:

- **Archive** to archive the email message.
Tip To display your archived messages, in the Inbox, press **MENU**, then touch **View labels > All Mail**.
- **Add star** or **Remove star** to assign a star or remove the star on the conversation.
- **Mark read** or **Mark unread** as desired. Unread messages or threads with unread messages display in bold in the Inbox.
- **Change labels** to add or change the label of the conversation.
Note You cannot use the phone to create labels.
- **Delete** to delete the email message.
- **More >**
 - **Back to Inbox** to return to your inbox.
 - **Mute** to mute the entire conversation. When you mute a message, new emails added to the conversation will not go to your inbox anymore. The conversation remains archived.
 - **Report spam** to report the email message as spam.

Set Google Mail settings

1 In the Inbox, press **MENU** and then touch **Settings**.

2 Set the following options:

- **Signature** Touch to enter a signature that is appended at the end of your emails.
- **Confirm delete** Select the check box to show a confirmation box when you delete a conversation.
- **Batch operations** Select the check box to show the batch operations feature. The Batch operations feature lets you archive, delete, or apply a label to multiple emails at once.
- **Labels** Touch to select which Google Mail labels to synchronize.
- **Email notifications** Select the check box to show a notification icon on the status bar when you receive a new email.

-
- Touch **Select ringtone** if you want your phone to ring when a new email message arrives. On the ring tone menu, select a ring tone specific to new email messages. The ring tone plays briefly when selected. If you don't want a ring tone to play when you receive a new email message, touch **Silent**. Then touch **OK** to confirm your ringtone selection.
 - Select **Vibrate** if you want your phone to vibrate when you receive a new email message.

5.3 Using Email

The Email application comes with an email wizard that lets you add external POP3 or IMAP email accounts from popular web-based email service providers such as Yahoo!® Mail Plus, AOL, and more, on your phone.

To open Email

Press **HOME**, then touch the Applications tab, and then touch **Email**.

Add an email account

- 1 Press **HOME**, then touch the Applications tab, and then touch **Email**.
- 2 In the Your accounts screen, touch **Next**.
- 3 Enter the email address and password of the email account you want to set up and then touch **Next**.

Notes

- If the email account you want to set up is not in the phone's email database, you will be prompted to manually enter the email account settings, such as the email server, protocol and more after touching **Next**.
 - Touch **Manual setup** instead of **Next** to directly enter the incoming and outgoing settings for the email account you are setting up.
- 4 Enter the name for the account and the name you want displayed in outgoing emails and then touch **Done**.

After creating one email account, you need to press **MENU**, then touch **Add account** to create another email account.

Compose and send emails

- 1 Press **HOME**, then touch the Applications tab, and then touch **Email**.
- 2 In the Your accounts screen, touch the email account you want to use.
- 3 In an email account inbox, press **MENU**, then touch **Compose**.
- 4 Enter the message recipient's email address in the **To** field. As you enter information, matching contacts will appear on the screen. Touch the recipient or continue entering the email address. If you are sending the email to several recipients, separate the email addresses with a comma. You can add as many message recipients as you want.
- 5 Enter the subject, then compose your message.
- 6 Touch **Send**.

Note Touch **Save as draft** or press the **BACK** button to save the message as a draft.

Manage emails on your external email account

To delete a message

- 1 On the email account inbox, touch and hold the email you want to delete.
- 2 On the options menu, touch **Delete**.

Edit or delete an external email account

You can edit or delete an external email account on your phone.

- 1 Press **HOME**, touch the Applications tab, then select **Email**.
- 2 Do one of the following:
 - To delete, touch and hold the account you want to remove, then touch **Remove account** on the options menu. When prompted to confirm deletion, touch **OK**.
 - To edit, touch and hold the account you want to edit, then touch **Account settings** on the options menu.

Add more email accounts

On the Your accounts screen, press **MENU** and then touch **Add account**.

5.4 Using Google Talk™

Google Talk is Google's instant messaging program. It lets you communicate with other people that also use Google Talk on a phone or on the web.

Note The Google Talk account that is set up is based on the Google Account that you used when you set up the phone.

Sign in and chat online

To sign in to Google Talk

Press **HOME**, touch the Applications tab, and then touch **Google Talk**.

Touch to change your online status message.

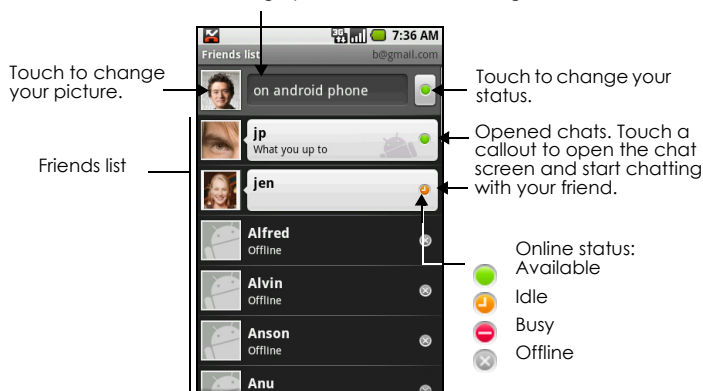

To add a new friend

You can only add people who have a Google Account.



- 1 In the Friends list, press **MENU** and then touch **Add friend**.
- 2 Enter the Google Talk instant messaging ID or Google email address of the friend you want to add.
Note When you add a friend with an instant messaging ID and has been saved in your contacts list, matching contacts will display on the screen as you enter information. You can touch the contact or continue entering the IM information.
- 3 Touch **Send invitation**.

To view and accept an invitation

- 1 In the Friends list, press **MENU** and then touch **Invites**. All chat invitations you have sent or received are listed on the pending invitations screen.
- 2 Touch a pending invitation, then touch **Accept** or **Decline**.

Note When someone you invite to chat accepts your invitation, the pending invitation disappears from the list.

To change your online status and message

- 1 Touch the online status icon  beside your name, then select the status you want on the menu.
- 2 Touch the text box on the left of your online status icon and then enter your status message.
- 3 Press  if you are using the hardware keyboard or touch **Done** on the onscreen keyboard.

Tip The status you set in Google Talk, here or on the web, can be displayed to your friends in other applications, including Google Mail, Google Maps (with Google Latitude™), IM, and Email.

To start a chat

- 1 Do one of the following:
 - Touch the name of a friend in the Friends list.
 - Navigate to a friend using the **TRACKBALL**, then press the **TRACKBALL**.

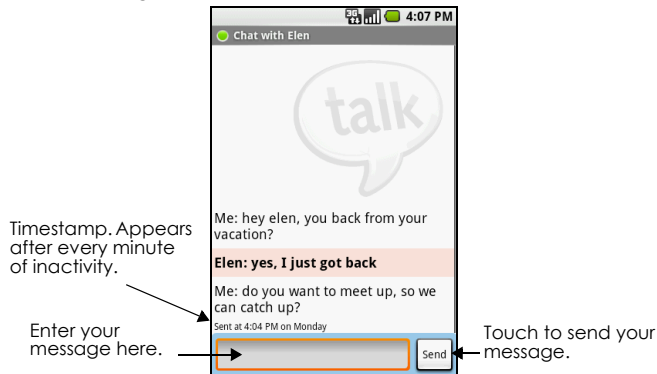

- 2 Chat with your friend by entering text.

Note To insert a smiley using the onscreen keyboard, touch and hold the smiley key to bring up the smiley menu. Touch a smiley to insert it into your message.

- 3 After entering your message, touch **Send**.

To switch between active chats

You can switch between chats if you have more than one chat going.

- 1 While on a chat screen or in the friends list, press **MENU** and then touch **Switch chats**.
- 2 On the panel that opens, touch the friend you want to chat with.

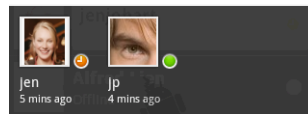

To close a chat

Do one of the following:

- In your Friends list, touch and hold a friend with an active chat and then touch **End chat** on the menu.
- While on a chat screen, press **MENU** and then touch **End chat**.

Manage your friends

Friends in your friends list is sorted by their online status — active chats, online, busy, and offline. Within the status groupings, friends are listed alphabetically.

By default, only the friends that you frequently communicate with — the most popular — are in the Friends list. If you want to display all your friends, press **MENU** and then touch **All friends**.

Tip To switch back to displaying only your most popular friends, press **MENU** and then touch **Most popular**.

To find a friend

In the Friends list, start entering the name of your friend to filter your list to show only friends with names that match what you have entered.

To block a friend

You can block a friend from sending you messages. When blocked, your friend is also removed from your Friends list.

- 1 In the Friends list, locate the friend you want to block.
Note If you cannot see the friend, Press **MENU** and then touch **All friends**.
- 2 Touch and hold the friend's name, then touch **Block friend**. Your friend is removed from your friends list and is added to the blocked friends list.

Note To unblock a friend, in the Friends list, press **MENU** and then touch **Blocked**. In the Blocked friends list, touch the name of the friend you want to unblock, then touch **OK** when prompted.

To pin a friend

You can pin a friend to make sure that friend always appears in your **Most popular** friends list.

- 1 In the Friends list, Touch and hold the friend's name to open the options menu.
Note If you cannot see the friend, Press **MENU** and then touch **All friends**.
- 2 Touch **Pin friend**.

Note To unpin a friend, in the Friends list, touch and hold the friend you want to unpin and then touch **Unpin friend** on the options menu.

To show a friend in the Most popular list

- 1 In the Friends list, touch and hold the friend's name to open the options menu.
Note If you cannot see the friend, Press **MENU** and then touch **All friends**.
- 2 Touch **Show friend**.

Note To keep a friend from appearing in the most popular list, touch and hold the friend's name, then touch **Hide friend** on the menu. If you pinned the friend, the pin will be removed when you hide the friend.

Mobile indicators

You can check what type of device your friend is using to chat in Google Talk. In the friends list, check the image that appears to the right of your friend's name.



When you do not see an image, it indicates that your friend signed in last from a computer.

You can also choose to show a mobile indicator. To show:

- 1 In the Friends list, press **MENU** and then touch **More > Settings**.
- 2 Select the **Mobile indicator** check box and then press **BACK**. The mobile indicator icon will display along with your name in other people's Friends list and will let your friends know what type of mobile device you are using.

Adjust instant messaging settings

To set notifications for new instant messages

You can set the phone to play a sound, vibrate, or display a notification icon in the status bar each time you receive a new instant message.

- 1 In the Friends list, press **MENU** and then touch **More > Settings**.
- 2 Do one or all of the following:
 - Select the **IM notifications** check box to receive a notification (🗨️) in the status bar when a new instant message arrives.
 - Touch **Select ringtone** to select the ring tone to use when a new instant message arrives. The ring tone briefly plays when selected. If you don't want a ring tone to play when you receive a new instant message, select **Silent**.
 - Select the **Vibrate** check box to vibrate your phone when you receive a new instant message.

To sign in automatically

You can sign in to your Google Talk account automatically every time you turn on your phone.

- 1 In the Friends list, press **MENU** and touch **More > Settings**.
- 2 Select the **Automatically sign in** check box.
- 3 Press **BACK** to save your setting.

Sign out

In the friends list, press **MENU** and touch **More > Sign out** when you want to sign out from Google Talk.

6 Getting Connected

6.1 Connecting to the Internet

Your phone's networking capabilities allow you to access the Internet through GPRS/3G/EDGE or Wi-Fi.

GPRS/3G/EDGE

Your phone will be automatically configured to use your wireless service provider's GPRS/3G/EDGE service when you turn on your phone (if the SIM card is inserted) for the first time.

To check the network connection you are using

- 1 Press **HOME > MENU**, and then touch **Settings**.
- 2 Touch **Wireless Controls > Mobile networks > Network operators** or **Access Point Names**.

To create a new access point

When you need to add another GPRS/3G/EDGE connection on your phone, obtain the access point name and settings (including username and password if required) from your wireless service provider.

- 1 Press **HOME > MENU**, and then touch **Settings**.
- 2 Touch **Wireless Controls > Mobile networks > Access Point Names**.
- 3 On the APNs screen, press **MENU** and then touch **New APN**.
- 4 In the Edit access point screen, enter the APN settings. Touch the APN setting item to edit it.
- 5 Press **MENU** and then touch **Save** when you finish setting up the new APN.

Wi-Fi

Wi-Fi provides wireless Internet access over distances of up to 300 feet (100 meters). To use Wi-Fi on your phone, you need access to a wireless access point or "hotspot".

Note The availability and range of the Wi-Fi signal depends on the number, infrastructure, and other objects through which the signal passes.

To turn Wi-Fi on and connect to a wireless network

- 1 Press **HOME > MENU**, and then touch **Settings > Wireless controls**.
- 2 Select the **Wi-Fi** check box to turn Wi-Fi on. The phone will scan for available wireless networks.
- 3 Touch **Wi-Fi settings**. The network names and security settings (Open network or Secured with WEP) of detected Wi-Fi networks are displayed in the Wi-Fi networks section.
- 4 Touch a Wi-Fi network to connect. When you selected an open network, you will be automatically connected to the network. If you selected a network that is secured with WEP, enter the WEP (security) key and then touch **Connect**.

Notes

- The next time your phone connects to a previously accessed secured wireless network, you will not be prompted to enter the WEP key again, unless you reset your phone to its factory default settings.
- Wi-Fi networks are self-discoverable, which means no additional steps are required for your phone to connect to a Wi-Fi network. It may be necessary to provide a username and password for certain closed wireless networks.

To check the wireless network status

You can check the current wireless connection status from the following:

- Status bar

When your phone is connected to a wireless network, the Wi-Fi icon  appears in the status bar and tells you the approximate signal strength (number of bands that light up). If **Network**

notification in Wi-Fi settings is enabled, this icon  appears in the status bar whenever the phone detects an available wireless network within range.

- Wi-Fi networks

On the Wireless controls screen, touch **Wi-Fi** settings, then touch the wireless network that the phone is currently connected to. The Wi-Fi network name, status, speed, signal strength, security information, and IP address are displayed.



Note If you want to remove the wireless network settings on your phone, touch **Forget** on this window. You will need to enter the settings again if you want to connect to this wireless network.

To connect to another Wi-Fi network

- 1 On the Wireless controls screen, touch **Wi-Fi settings**. Detected Wi-Fi networks are displayed in the Wi-Fi networks section.

Tip To manually scan for available Wi-Fi networks, on the Wi-Fi settings screen, press **MENU** and then touch **Scan**.

- 2 Touch another Wi-Fi network to connect to it.

Note If the wireless network you want to connect to is not in the list of detected networks, scroll down the screen, then touch **Add Wi-Fi network**. Enter the wireless network settings, then touch **Save**.

6.2 Using Browser

Open Browser to start surfing the web. Browser is fully optimized and comes with advanced functionalities that let you enjoy Internet browsing on your phone.

Note You must have an active data (3G, GPRS), or Wi-Fi connection to access the Internet.

To open Browser

Do one of the following:

- Press **HOME**, then touch **Browser**.
- Press **HOME**, touch the Applications tab, and then touch **Browser**.

Note Browser automatically opens when you touch a web link in an email or text message.

To go to a web page

- 1 On the Browser screen, press **MENU** and then touch **Go**.
- 2 Enter the web page address using the keyboard. As you enter the address, matching web page addresses will appear on the screen. Touch an address to go directly to that web page or continue entering the web page address.
- 3 Touch **Go**.



To set your home page

- 1 Press **MENU** and then touch **More > Settings > Set home page**.
- 2 Enter the URL of the web site you want to use as your home page and then touch **OK**.

View web pages

Browser offers a host of features that let you view web pages just like on a desktop computer.

To change the screen orientation to landscape view

Turn your phone sideways to view the web page in landscape mode. The screen orientation automatically adjusts to how you hold the phone.

Note The **Orientation** check box in **HOME > MENU > Settings > Sound & display** needs to be selected for the screen orientation to automatically change.

To navigate on a web page

You can roll the **TRACKBALL** or slide your finger on the screen in any direction to navigate and view other areas of the web page.

You can also use scale and scroll to magnify an area of the web page for easy viewing. To use scale and scroll:

- 1 On a web page, press the **TRACKBALL** twice. The web page zooms out to fit the height of the screen and the magnifying window appears.
- 2 Touch and hold the magnifying window, then drag it to the area of the page that you want to view more closely. You can also roll the **TRACKBALL** to move the magnifying window on any area of the screen.

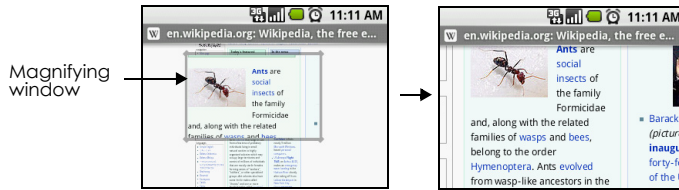

Magnifying window

- 3 Release your finger or press the **TRACKBALL** to magnify the view. The view is magnified using the zoom ratio used when you activated scale and scroll.

To zoom in or out on a web page

Slide your finger to one direction on the screen to activate the zoom controls.



To open a new browser window

Open multiple browser windows to make it easier for you to switch from one web site to another. You can open up to 8 browser windows.

To open a new window, press **MENU** and then touch **New window** while browsing a web page. A new browser window opens and goes to the home page that is set.

Note If you have two or more browser windows opened, press **MENU** and then touch **Windows** to let you add more browser windows.

To switch between browser windows

- 1 On a browser window, press **MENU** and then touch **Windows**.

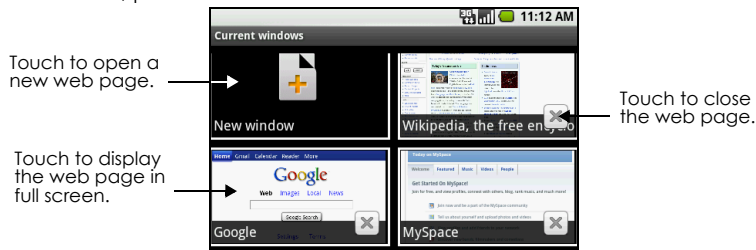

- 2 On the Current windows screen, touch the browser window you want to view.

To close a browser window, touch **x** on the browser window you want to close.

To find text within a web page

- 1 While viewing a web page, press **MENU** and then touch **More > Find on page**.
- 2 Enter the search item. As you enter characters, matching characters will be highlighted in green. Touch the left or right arrow to go to the previous or next matching item.

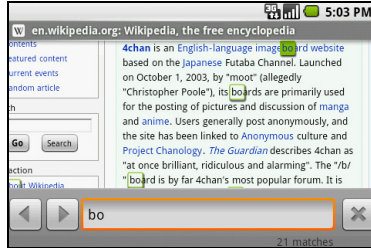

Tip Touch  to close the search bar.

To copy text on a web page

Copy text from web pages and then paste them on emails or your SMS/MMS messages.

- 1 Open the web page where you want to copy text.
- 2 Locate the text you want to copy and then press **MENU** and then touch **More > Select text**.
Tip Zoom out of the page before you select text.
- 3 Position your finger at the start of the text you want to copy and then drag to the end of the text you want to copy. Copied text are highlighted in pink.
- 4 Release your finger from the screen.

To paste text on a email or SMS/MMS message, touch and hold the text box on a message or email and then touch **Paste** on the options menu.

Manage links, history, and downloads

To select links in web pages

Navigate to links on a web page using the **TRACKBALL**. Links are enclosed in a box when selected.

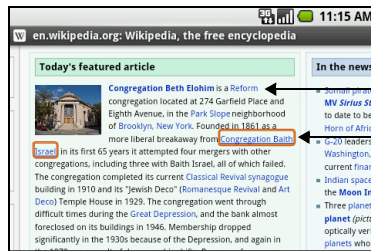

| Link | What to do |
|-------------------------------|--|
| Web page address (URL) | <ul style="list-style-type: none">• Touch the link to open the web page.• Touch and hold the link to open a menu that allows you to open, bookmark, copy to the clipboard, or share the link via email. |

| Link | What to do |
|----------------------|--|
| Email address | <ul style="list-style-type: none"> • Touch to send an email message to the email address. • Touch and hold, then touch Copy on the menu to copy the email address to the clipboard. You can paste the email address later when creating a new contact or sending a new email message. |

Browser also recognizes some phone numbers and addresses that allow you to call the phone number or locate the address in Google Maps™. Recognized phone numbers and addresses are highlighted in green when navigated to.

| Link | What to do |
|-------------------------|---|
| Location address | Touch the address to open Google Maps and locate the address. |
| Phone number | Touch to open the Phone screen to call the phone number. |

Tip When links are too small for touching directly on the screen, highlight it with the **TRACKBALL**, then either press the **TRACKBALL** to open the link, or press and hold the **TRACKBALL** to select an option from the menu.

To check Browser history

On the Browser screen, press **MENU** and then touch **Bookmarks > History** tab. Touch an item to open the web page.

Tip You can also check your most visited web pages by pressing **MENU** and then touching **Bookmarks > Most visited** tab.

To allow download of web applications

Before you can download web applications, you must first enable downloading from the phone settings.

- 1 Press **HOME > MENU**, and then touch **Settings > Applications**.
- 2 Select the **Unknown sources** check box.
- 3 When the Attention dialog box opens, touch **OK**.

Note All downloaded applications are saved to the storage card. Before you download an application from the web, make sure that you have installed a storage card on your phone. For information on how to install a storage card, refer to "To install the storage card" on page 19.

Warning! Applications downloaded from the web can be from unknown sources. To protect your phone and personal data, download applications only from trusted sources such as Android Market. Refer to "Installing an application" on page 96 for details.

To view your downloads

On a browser screen, press **MENU** and then touch **More > Downloads**.

Manage bookmarks

You can store as many bookmarks as you want on your phone.

To bookmark a web page

- 1 On a browser screen, go to the web page you want to book mark.
- 2 Press **MENU** and then touch **Bookmarks**. The bookmarks screen opens.
- 3 On the **Bookmarks** tab, touch **Add bookmark**.
- 4 Edit the bookmark **Name** if needed and then touch **OK**.

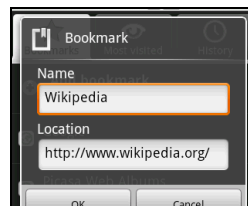

To open a bookmark

- 1 On the Browser screen, press **MENU** and then touch **Bookmarks**.
- 2 On the **Bookmarks** tab, do one of the following:
 - Touch the bookmark you want to open.
 - Touch and hold the bookmark you want to open, then touch **Open** or **Open in new window** on the options menu.

To edit a bookmark

- 1 On the Browser screen, press **MENU** and then touch **Bookmarks**.
- 2 On the **Bookmarks** tab, touch and hold the bookmark you want to edit.
- 3 Touch **Edit bookmark** on the options menu. The edit bookmark dialog box appears.
- 4 Enter your changes and touch **OK**.

Adjust Browser settings

On the Browser screen, press **MENU** and then touch **More > Settings** to set the Browser settings and options.

6.3 Using Bluetooth

Bluetooth is a short-range wireless communications technology that allows Bluetooth devices to exchange information over a distance of about eight meters without requiring a physical connection.

Bluetooth on your phone operates in three different modes:

- **On.** Bluetooth is turned on. Your phone can detect other Bluetooth-enabled devices, but not vice versa.
- **Discoverable.** Bluetooth is turned on, and all other Bluetooth-enabled devices can detect your phone.
- **Off.** Bluetooth is turned off. In this mode, you can neither send nor receive information using Bluetooth.

Notes

- By default, Bluetooth is turned off. If you turn it on, then turn off your phone, Bluetooth also turns off. When you turn on your phone again, Bluetooth automatically turns on.
- Turn off Bluetooth when not in use to conserve battery power, or in places where using a wireless device is prohibited, such as on board an aircraft and in hospitals.

To turn on Bluetooth and make the phone discoverable

- 1 Press **HOME > MENU**, and then touch **Settings**.
- 2 Touch **Wireless controls**, then select the **Bluetooth** check box to turn on Bluetooth. When on, the Bluetooth icon  appears in the status bar.
- 3 Touch **Bluetooth settings**, then select the **Discoverable** check box to make the phone discoverable to other Bluetooth devices that are within range.

Important Your phone will be discoverable for up to two minutes.

To change the phone name

The phone name identifies your phone in a Bluetooth network.

- 1 Make sure that you have turned Bluetooth on.
- 2 On the Wireless controls screen, touch **Bluetooth settings > Device name**.
- 3 Enter the name for your phone in the dialog box, then touch **OK**.

To pair and connect a Bluetooth stereo/hands-free headset or car kit phone

You can connect your phone to a Bluetooth stereo or headset or a Bluetooth car kit phone and use those devices to listen to music, and send and/or receive calls. Before you can use a Bluetooth stereo/hands-free headset or car kit phone, you must pair it first with your phone.

Important The phone supports the following Bluetooth profiles: Headset, Handsfree, A2DP, and AVRCP.

- 1 Press **HOME**, then press **MENU**, and then touch **Settings**.
- 2 Touch **Wireless controls > Bluetooth settings** and then select the **Bluetooth** check box. Your phone will start to scan for Bluetooth devices within range and will display all detected devices below the Bluetooth devices section.

Tips

- If you do not find the device in the list, touch **Scan for devices** to scan again.
 - Make sure that the Bluetooth device that you want to pair with is set to discoverable mode. Consult the Bluetooth device's documentation to learn how to set it to discoverable mode.
- 3 Touch the hands-free headset or car kit phone in the list to start pairing.

Note For some Bluetooth devices, you need to enter a passcode to pair with the Bluetooth device. You can try "0000" as the passcode. If that does not work, consult the Bluetooth device's documentation.

- 4 The pairing and connection status will appear below the hands-free headset or car kit phone name in the Bluetooth devices list. When the other Bluetooth stereo/hands-free headset or car kit phone is connected to your phone, the Bluetooth connected icon  will appear in the status bar. You can now start using the Bluetooth stereo/hands-free headset or car kit phone to make and/or receive phone calls.

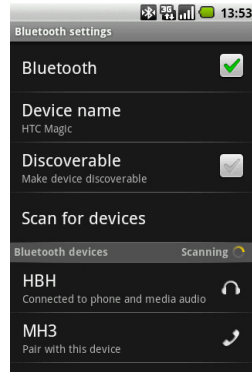

The  icon represents that the device is a stereo Bluetooth headset (A2DP Bluetooth profile). You need to use a stereo Bluetooth headset (A2DP Bluetooth profile) if you want to listen to music through a Bluetooth headset.

The  icon represents that the device is a mono Bluetooth headset (Headset and Handsfree Bluetooth profiles).

Notes

- Pairing between two Bluetooth devices is a one-time process. Once pairing is created, the devices can recognize the partnership and exchange information without entering a passcode again.
- If you pair with a second headset while connected to the first, the first headset will be disconnected. To switch connection back to the first headset, you must manually select that headset again in the Bluetooth devices list

To disconnect a Bluetooth stereo/hands-free headset or car kit phone

- 1 Press **HOME** > **MENU**, and then touch **Settings**.
- 2 Touch **Wireless controls** > **Bluetooth settings**.
- 3 Navigate to the Bluetooth devices section, then touch and hold the connected hands-free headset or car kit phone.
- 4 Touch **Disconnect**.

Touch **Unpair** if you want the phone to erase all pairing information with the hands-free stereo/headset or car kit phone. You will be prompted to enter the passcode again when you connect to that Bluetooth device.

7 Getting Around with Maps

7.1 Using Maps

Maps lets you track your current location, view real-time traffic situations, and receive detailed directions to your destination. It also provides a search tool where you can locate places of interest or an address on a vector or aerial map, or view locations in street level.

Notes

- You need an active data (3G/GPRS) or Wi-Fi connection to use Maps.
- The Maps application does not cover every country or city.

Enable Location source

Before you open Maps and find your location or search for places of interest, you must enable **Location source**.

- 1 Press **HOME**, press **MENU** and then touch **Settings**.
- 2 Touch **Security & location**.
- 3 Navigate to the My Location sources section, then select **Use wireless networks, Enable GPS satellites**, or both.

Note Selecting **Enable GPS satellites** lets you locate places of interest in street-level. However, this requires a clear view of the sky and more battery power.

Open Maps

Do one of the following:

- Press **HOME**, then touch **Maps**.
- Press **HOME**, touch the Applications tab and then touch **Maps**.

Find your location on the map

On the Maps screen, press **MENU** and then touch **My Location**. Your location is shown on the map as a blinking blue dot.

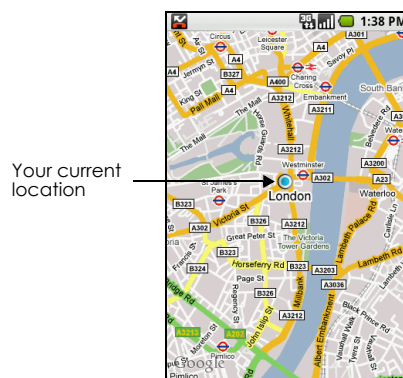

7.2 Searching for Places of Interest

To search for a place of interest

- 1 On the Maps screen, press **MENU** and then touch **Search**.
- 2 Enter the place you want to search in the search box. You can enter an address, a city, or type of business or establishment (for example, museums in london).

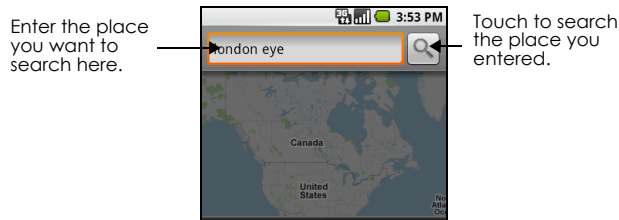

Tip As you enter information, a list of all the places which you have searched or visited before appears on the screen. You can also touch an address on the menu to show its location on the map.

- 3 Touch **Search**.
- 4 Touch a place in the list to show its location on the map.

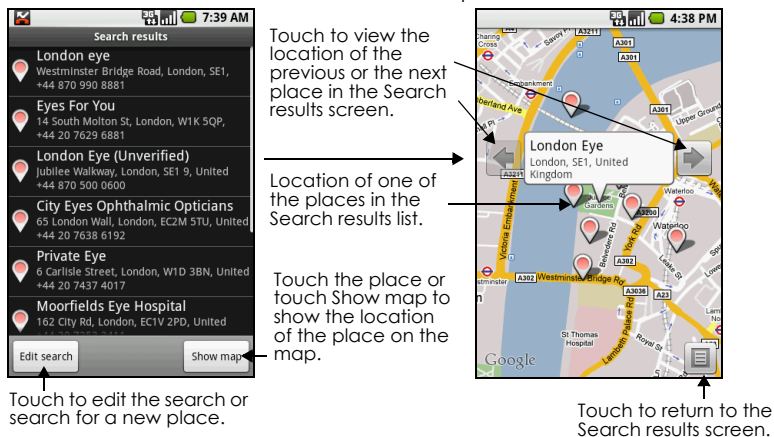

Tip On the map, roll the **TRACKBALL** left or right to view the location of the previous or the next place in the Search results list.

- 5 Touch the call-out on the map to open the location details and options.

7.3 Viewing Maps

While viewing a map, take advantage of the following zoom and navigation techniques.

Zoom in or out on a map

Touch the screen to show the zoom controls.

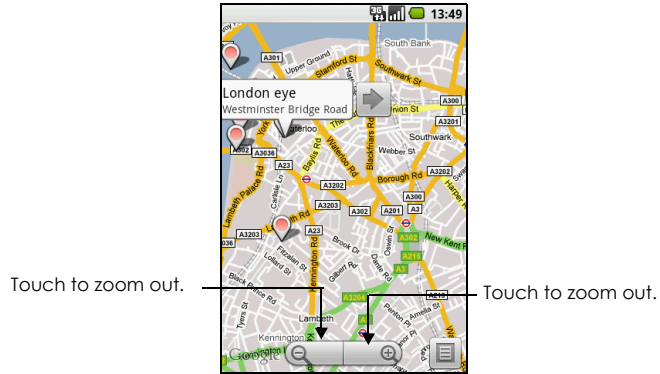

Navigate on a map

Roll the **TRACKBALL** or slide your finger on the screen in any direction to view other areas of the map.

To change a map mode

When viewing a map, you can switch to another map mode. Press **MENU** and then touch **Map mode**. Select from **Map**, **Satellite**, **Traffic**, or **Street View**.



Map mode

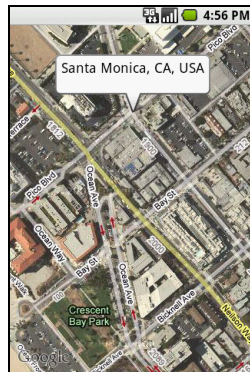

Satellite mode

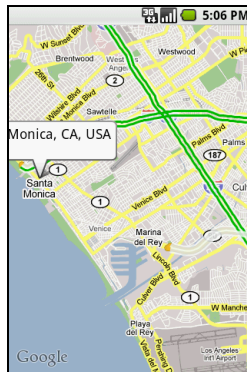

Traffic mode

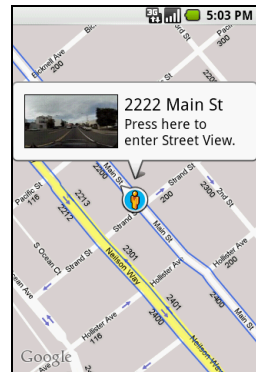

Street view mode

| | |
|--|---|
| Map mode | This is the default view and displays a map, complete with names of streets, rivers, lakes, mountains, parks, and boundaries. |
| Satellite mode | Maps uses the same satellite data as Google Earth™ mapping service. Satellite images are not real-time. Google Earth acquires the best imagery available, most of which is approximately one to three years old. |
| Traffic mode (available only in selected areas) | Real-time traffic conditions are displayed over roads as color-coded lines. Each color represents how fast the traffic is moving. |
| Street View mode (available only in selected areas) | Provides a street-level view of the location. Blue outlined roads indicate that street view is available on those locations. While viewing a Street View of a location, press MENU and then touch Compass mode to turn Compass mode on. Tilt, pan, or turn your phone to view the area around the selected location. |

7.4 Getting Directions

Use Maps to get detailed directions to your destination.

To get directions

- 1 While viewing a map in any mode (except in Street View), press **MENU** and then touch **Directions**.
- 2 Enter the starting point in the first text box, then enter your destination in the second text box.

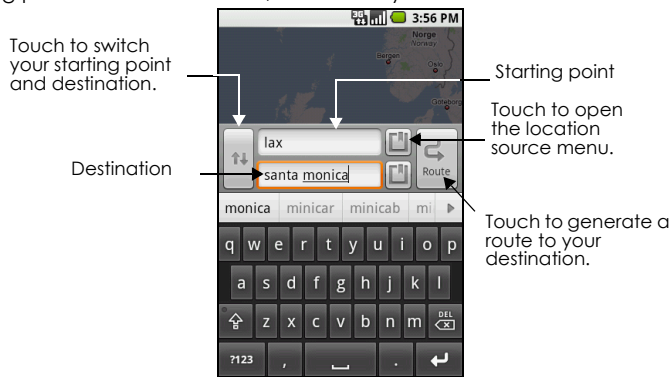

You can also touch  to open the location source menu and select a starting point and destination address.

3 Touch **Route**. The directions to your destination appears in a list.

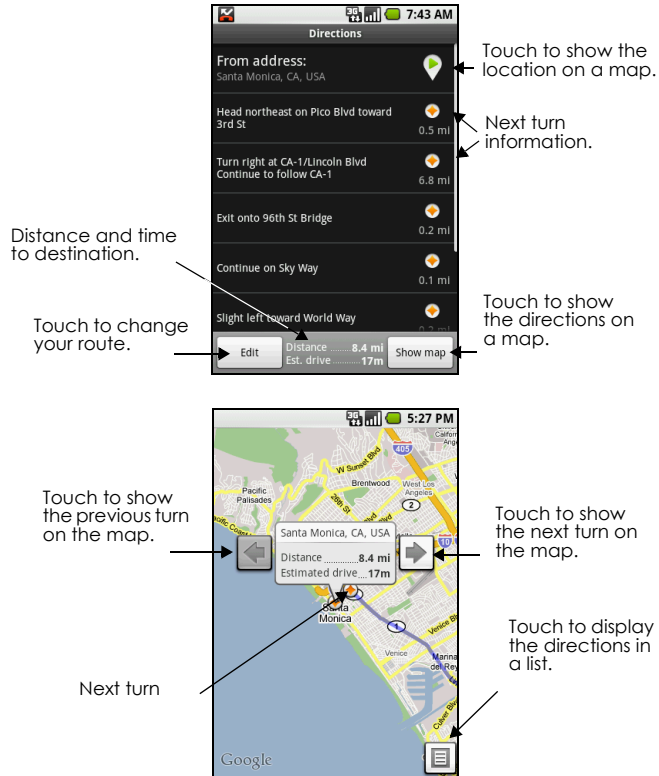

When you are finished viewing or following the directions, press **MENU**, then **More**, then touch **Clear map** to reset the map. Your destination is automatically saved in the Maps history.

7.5 Finding your friends with Google Latitude™

Google Latitude user location service lets you and your friends share locations and status messages with each other. It also lets you send instant messages and emails, make phone calls, and get directions to your friends' locations.

Your location is not shared automatically. You must join Latitude, and then invite your friends to view your location or accept their invitations.

Open Latitude

To join Latitude

- 1 While viewing a map in any mode (except in Street View), press **MENU** and then touch **Join Latitude**.
- 2 Read the privacy policy. If you agree with it, touch **Agree & share**.

To open Latitude after joining

While viewing a map in any mode (except in Street View), press **MENU** and then touch **Latitude**.

Share your locations

After you join Latitude, you can start sharing your locations with your friends. Only friends that you have explicitly invited or accepted can see your location.

Invite friends

To share your location with friends and request to see their locations

- 1 In Latitude, press **MENU** and then touch **Add friends**.
- 2 Choose how to add friends:
 - **Select from Contacts**. Select any number of friends from your Contacts. Friends who already use Latitude have a  icon next to their names.
 - **Add via email address**. Enter an email address.
- 3 Touch **Add friends**.
- 4 Touch **OK**.

If your friends already use Latitude, they receive an email request and a notification on Latitude. If they have not yet joined Latitude, they receive an email request that tells them to sign in to Latitude with their Google Account.

Accept an invitation

When you get a sharing request from a friend, you can:

- **Accept and share back**. You can see your friend's location, and your friend can see yours.
- **Accept, but hide my location**. You can see your friend's location, but they can't see yours.
- **Don't accept**. No location information is shared between you and your friend.

You can change how your location is shared with each friend at any time. Refer to "To share your location with friends and request to see their locations" on page 81 for more details.

Show your friends

You can show your friends using the map view or the list view.

Map view

When you open Google Maps, it shows your friends' locations. Each friend is represented by a photo icon with an arrow pointing at his or her approximate location. If a friend has opted to enable city-level sharing, his or her icon will not have an arrow and it appears in the middle of the city. Refer to "To share your location with friends and request to see their locations" on page 81 for more details.

If your friends use Google Talk, those friends' online status (available, busy, and so on) is indicated by a circular icon below those friends' pictures. For more information, see "Using Google Talk™" on page 63.

To see your friend's profile and connect with him or her, touch the photo. This will display your friend's name, then touch the balloon right above his or her icon.

To see other friends, touch either one of the arrow buttons next to the balloon.

List view

To show a list of your friends, in Maps, press **MENU** and then touch **Latitude**.

To see a friend's profile and connect with him or her, select your friend's name from the list.

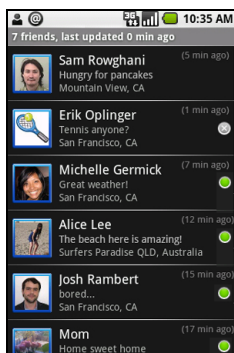
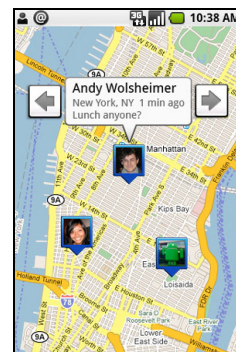

Connect with your friends

Touch a friend's contact details balloon in map view or touch a friend in list view to open the friend's profile. In the profile screen, you can communicate with your friend and set privacy options.

| | |
|-------------------------------|--|
| Show on map | Find a friend's location on the map. |
| Chat using Google Talk | Send an instant message. Google Talk opens a chat window with that friend. |
| Send email | Send an email. Google Mail opens an email addressed to that friend. |
| Directions | Get directions to the friend's location. |

| | |
|---------------------------------------|--|
| Hide from this friend | Stop sharing your location with this friend. Your friend cannot see your photo icon on the map. To share your location with this friend again, touch Unhide from this friend . |
| Share only city level location | Share only the city you are in, not the street-level location. Your friend can see your photo icon in the middle of the city you are in. To share more precise location again, touch Best available location . |
| Remove | Remove the friend from your list and stop sharing locations with him or her altogether. |

Control what you share

You have control over how and when you can be found by your friends. Only the last location sent to Latitude is stored with your Google Account. If you turn off Latitude or are hiding, no location is stored.

To change your public profile

- 1 in Maps, press **MENU**, touch **Latitude**, and then touch your contact details balloon.
- 2 Set the following options to your preferences.

| | |
|-----------------------------|---|
| Show on map | See your location on a map. |
| Change your status | Change the status message, which is shared across other Google products and features, such as Google Talk and Google Mail. After you touch Change your status , type your new status in the dialog box, and then touch OK . |
| Change your photo | Change the picture, which is also shared across other Google products and features. After you touch Change your photo , you can either take a picture of yourself with the phone or select a picture from Gallery. Refer to "Using Camera and Camcorder" on page 84 and "Using Gallery" on page 86 for more details. |
| Edit privacy setting | Manage how your location is shared with all your friends. Select one of the following options: <ul style="list-style-type: none"> • Detect your location. Let Latitude automatically detect and update your location as you move around. The update frequency is determined by several factors, such as your phone's battery charge level and how recently your location has changed. Note: You must have My location sources enabled. To learn how to enable My location sources, refer to "Using Maps" on page 76. • Set your location. Manually select a location on the map. • Hide your location. Hide your location from all your friends. They will not be able to see your location on their maps. You can also hide your location only to certain individuals. Refer to the next section for more details. • Turn off Latitude. Disable Latitude and stop sharing. Your friends cannot see your location. You can always join Latitude again. |

8 Camera and Multimedia

8.1 Using Camera and Camcorder

Use Camera or Camcorder to take and share pictures and videos. Your phone comes with a 3.2 megapixel camera with auto-focus feature that lets you capture sharp pictures and videos.

Before you proceed

- You must install a storage card before you use the Camera or Camcorder. All pictures or videos that you capture on your phone are stored on the storage card. For more information on how to install a storage card on your phone, refer to "To install the storage card" on page 19.
- The camera lens at the back of the phone is covered by a protective film during shipment. Make sure that you peel this film off before using the camera.

To open the Camera or Camcorder

- Press **HOME**, touch the Applications tab and then touch **Camera** if you want to capture photos or **Camcorder** if you want to shoot videos. The screen automatically switches to landscape orientation when you open Camera or Camcorder.
- Press the **CAPTURE** button as a shortcut.

Tip You can easily switch to the other capture mode while you are in Camera or Camcorder. Refer to "Capture modes" in this chapter for details.

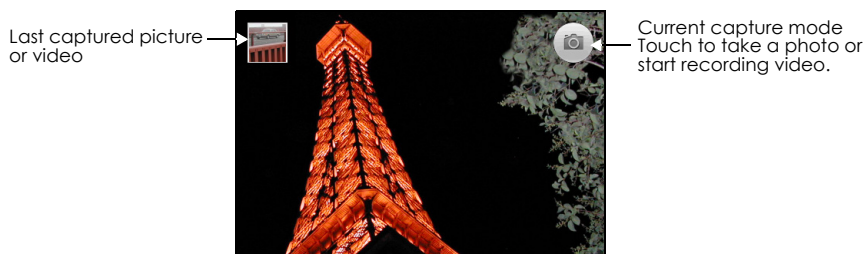

To close the Camera or Camcorder

On the Camera screen, press **HOME** or **BACK**.

Capture modes

The phone offers two capture modes: Camera and Video.

To change the capture mode



On the Camera screen, press **MENU** and then touch **Switch to video** or **Switch to camera**.

Take pictures

- 1 Press **HOME**, touch the Applications tab and then touch **Camera** or if you are in Camcorder, press **MENU** and then touch **Switch to camera**.
- 2 Frame your subject on the screen.
- 3 Touch  onscreen to take the picture or press the **CAPTURE** button.

Shoot videos

- 1 Press **HOME**, touch the Applications tab and then touch **Camcorder** or if you are in Camera, press **MENU** and then touch **Switch to video**.
Tip You can change the capture video quality by pressing **MENU** and then touching **Settings > Select video quality**.
- 2 Frame your subject on the screen.

- 3 Touch  onscreen to start capturing video. Touch  onscreen to stop capturing video.

Tip You can press the **CAPTURE** button to toggle between starting and stopping the video capture.

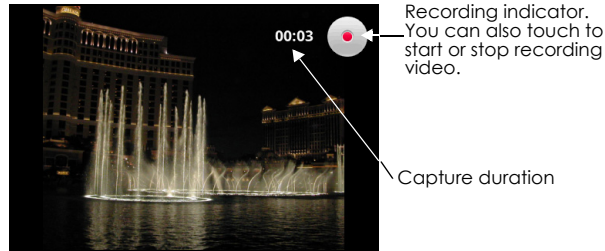

Important You can capture a maximum of 10 minutes of video using the phone. When the last minute is reached, the duration display will change to red and start a countdown.

Post capture

After capturing, a thumbnail of the photo or video you have just captured appears at the upper-left corner of the screen. Touch the thumbnail to open the post capture icons. The post capture icons let you view the file in Gallery, set a photo as a contact icon or wallpaper, play back the video file, and share the file with friends.

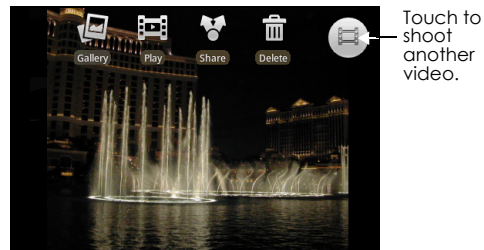
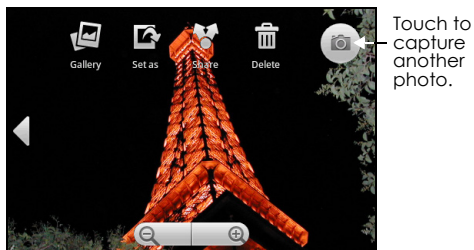

Copying photos and video to storage

To copy pictures and videos into the storage card

- 1 Set the phone's storage card as a USB drive. Refer to "Using the Phone's Storage Card as a USB Drive" on page 31 for details.
- 2 On the computer, navigate to the USB drive and open it.
- 3 Create a folder on the root folder of the storage card.
Tip You can also create and use folders to organize your pictures or videos into albums inside the folder you have created.
- 4 Copy the files into the folder you have created.
- 5 After copying the files, unmount or eject the drive as required by your computer's operating system to safely remove the phone.
- 6 Disconnect the phone from the computer.

8.2 Using Gallery

Gallery lets you view photos and play back videos. For photos, you can also do basic editing tasks, set them as your wallpaper or contact picture, and share to your friends.

To open Gallery

- Press **HOME**, touch the Applications tab and then touch **Gallery**.
- While on the Camera screen, press **MENU** and then touch **Gallery**.

If you stored your files in folders (directories) on the storage card, Gallery will display these folders as separate albums. The top left album contains all the pictures in the storage card.

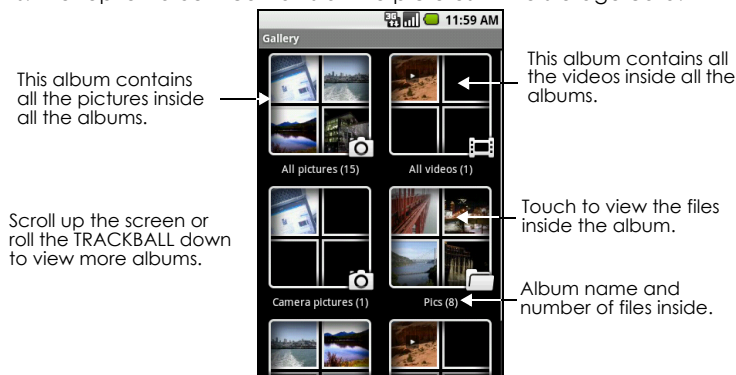

Note Depending on the number of pictures stored on the storage card, it may take a while to load all your photos on the screen.

To close Gallery

While in the Gallery screen, press **HOME** or **BACK** to close the application.

Note If you opened Gallery from the Camera application, the screen returns to the Camera screen when you press **BACK**.

Work with pictures

Once you have taken a picture, you can view it or share it with friends.

To view pictures

1 On the Gallery screen, touch an album to view the pictures inside the album

Note If there are no picture albums, slide your finger upward or downward the screen, or roll the **TRACKBALL** up or down to browse through individual pictures.

2 Touch a thumbnail to view it in full screen. You can also touch and hold the thumbnail, then touch **View** on the options menu to open it.

Tip You can choose to display small or large thumbnails or sort your album and display the latest pictures first or last. On the Gallery screen, press **MENU** and then touch **Settings**. Navigate to the General settings section, touch **Display size** or **Sort order**, then adjust the settings accordingly.

To browse through pictures

When viewing pictures in full screen, do one of the following:

- Touch the left area of the screen to view the previous picture, or touch the right area of the screen to view the next picture.
- Touch the screen to display the scroll arrows. Touch the left arrow to view the previous picture, or touch the right arrow to view the next picture.
- Roll the **TRACKBALL** left to view the previous picture, or roll it right to view the next picture in the album or in the pictures list.

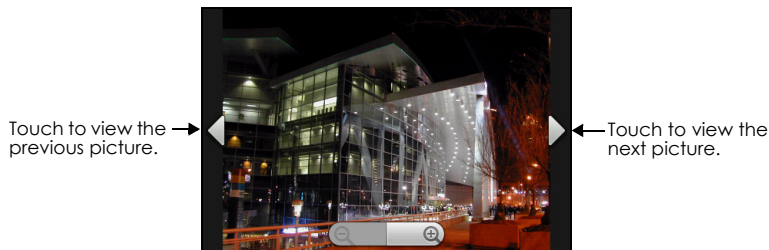

To zoom in or out on a picture

Touch the screen to activate the zoom control.

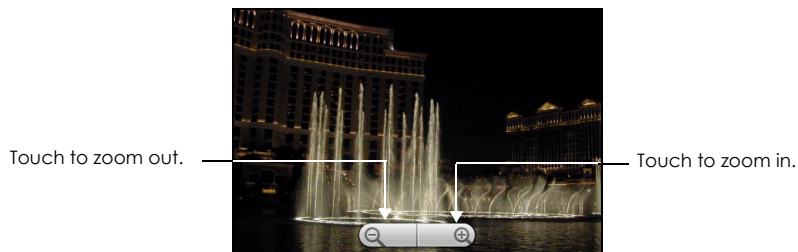

To view a picture in landscape orientation

Turn your phone sideways to view the picture in landscape mode. The picture orientation automatically adjusts to how you hold the phone.

Notes

- The **Orientation** check box in **Home > MENU > Settings > Sound & display** needs to be selected for the screen orientation to automatically change.
- If you want to rotate the picture and save the rotated state, see "To rotate and save the rotated state" below.

To rotate and save the rotated state

- 1 In the Gallery screen, touch and hold the picture you want to rotate or if you are viewing the picture in full screen, press **MENU**.
- 2 In the options menu, touch **Rotate** and then select either **Rotate left** or **Rotate right**.

Note The Picture rotates 90 degrees counter-clockwise (Rotate left) or 90 degrees clockwise (Rotate right) each time you touch one of the Rotate options.

To crop a picture

- 1 While viewing a picture in full screen, press **MENU** and then touch **Crop**. The cropper tool appears.
- 2 Do one of the following:
 - To adjust the cropper size, touch and hold the edge of the cropper tool. When the cropper arrows appear, drag your finger inward to or outward from the center of the cropper to resize it.
 - To keep the aspect ratio of the cropper while resizing, touch and hold one of the 4 corners.
 - To move the cropper to another area on the picture, touch and hold inside the cropper, then drag it with your finger to the desired position.

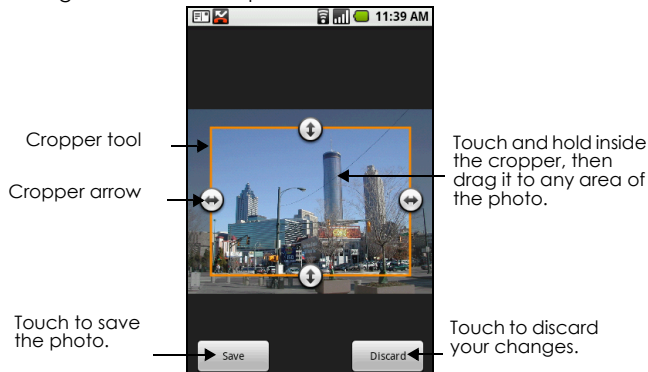

- 3 Touch **Save** to apply the changes to the picture.

Note The cropped picture is saved in the storage card as a copy. The original picture remains unedited.

To send a picture using Email

- 1 While viewing a picture in full screen, press **MENU**, then touch **Share**.
- 2 When prompted, touch **Email** or **Google Mail**.
- 3 The picture is automatically attached to your email. Compose your message, then touch **Send**. For more information on how to create and send emails, refer to "Using Google Mail™" on page 58.

To send a picture using Messaging

- 1 While viewing a picture in full screen, press **MENU**, then touch **Share**.
- 2 When prompted, touch **Messaging**.

-
- 3 The picture is automatically attached to your message. Compose your message, then touch **Send**. For more information on how to create and send messages, refer to "Sending Text and Multimedia Messages" on page 52.

To upload a picture to Picasa

You need to be signed in to a Google Account to be able to upload pictures to the Picasa photo organizing service.

- 1 While viewing a picture in full screen, press **MENU** and then touch **Share**.
- 2 When prompted, touch **Picasa**.
- 3 Enter a **Caption** for the picture and select the **Album** where you want to upload the picture.

Tip Touch **+** to create a new album where you can upload the picture.

- 4 Touch **Upload**. You can view the photos online at <http://picasaweb.google.com>.

Tip You can view the upload progress by opening the Notifications panel and then touching **Picasa**. Refer to "To open the Notifications panel" on page 27 to learn how to open the Notifications Panel.

Work with videos

Once you have taken a video, you can view it or share it with friends.

To watch videos

On the main Gallery screen, touch a video album and then touch the video you want to watch to start playing back the video.

Touch the screen to show the playback controls.

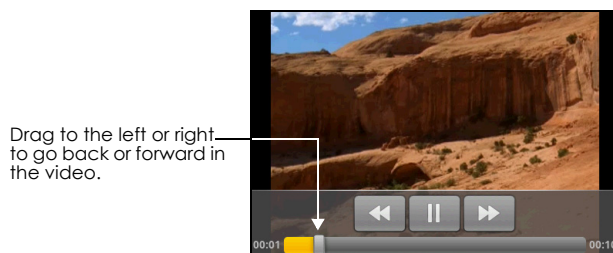

To send a video using Email

There is a 3MB limitation on the size of a video file that can be shared. If you want to share a video that you captured using the phone, this is approximately 1 minute of high quality or 2 minutes of low quality.

- 1 While viewing videos in a list, touch and hold the video, and then touch **Share** on the options menu.
- 2 When prompted, touch **Email** or **Google Mail**.
- 3 The video is automatically attached to your email. Compose your message, then touch **Send**. For more information on how to create and send emails, refer to "Using Google Mail™" on page 58.

To send a video using Messaging

There is a 3MB limitation on the size of a video file that can be shared. If you want to share a video that you captured using the phone, this is approximately 1 minute of high quality or 2 minutes of low quality.

- 1 While viewing videos in a list, touch and hold the video, and then touch **Share** on the options menu.
- 2 When prompted, touch **Messaging**.

-
- 3 The picture is automatically attached to your message. Compose your message, then touch **Send**. For more information on how to create and send messages, refer to "Sending Text and Multimedia Messages" on page 52.

To share videos on YouTube™

You can share your videos by uploading them to the YouTube user-generated content website. Before you do this, you must create a YouTube account and sign in to that account on your phone. There is a 3MB limitation on the size of a video file that can be shared. If you want to share a video that you captured using the phone, this is approximately 1 minute of high quality or 2 minutes of low quality.

- 1 While viewing videos in a list, touch and hold the video, and then touch **Share** on the options menu.
- 2 When prompted, touch **YouTube**.
- 3 Enter a **Title**, **Description**, and **Tags** for your video. Select the **Public** check box if you want to share the video with everyone.

- 4 Touch **Upload**.

Tip You can view the upload progress by opening the Notifications panel and then touching **YouTube**. Refer to "To open the Notifications panel" on page 27 to learn how to open the Notifications Panel.

8.3 Viewing Videos on YouTube™

YouTube is an online video streaming service that allows you to view, search, and upload videos.

Note You must have an active data (3G/GPRS/EDGE) or Wi-Fi connection to access YouTube.

To open YouTube

Press **HOME**, touch the Applications tab and then touch **YouTube**.

The YouTube screen appears with the videos grouped into categories, such as **Featured**, **Most popular**, **Most viewed**, **Top rated**, and more.

To close YouTube

While on the YouTube screen, press **HOME** or **BACK** to close YouTube.

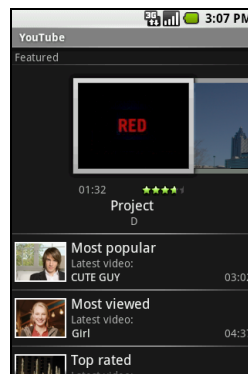

Watch YouTube videos

- 1 On the YouTube screen, select a video to watch from the available categories. Touch a category to see the available videos for that category.
- 2 Touch a video to play it.

Note The screen automatically switches to landscape orientation when you play a video.

-
- 3 Touch the screen to display the playback controls.

Drag to the left or right to go back or forward in the video.

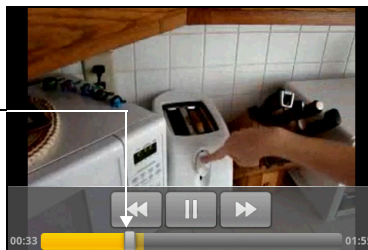

4. Press **BACK** to stop playback and return to the videos list.

Search for videos

- 1 On the YouTube screen, press **MENU** and then touch **Search**.
- 2 Enter a search keyword, then touch .
- 3 The number of search results appears below the status bar. Scroll through the results and touch a video to watch it.

To clear the search history

- 1 Press **MENU** and then touch **Settings**.
- 2 Touch **Clear search history** and then touch **OK** when prompted.

8.4 Using Music

Music plays digital audio files from the phone's storage card. Music supports the following music file formats: MP3, M4A (iTunes application AAC, DRM-free), AMR, WMA (8), MIDI, WAV, OGG Vorbis.

Since Music only plays audio files saved on the storage card of your phone, you must copy your audio files to the storage card before you open Music.

To copy music into the storage card

- 1 Set the phone's storage card as a USB drive. Refer to "Using the Phone's Storage Card as a USB Drive" on page 31 for details.
- 2 On the computer, navigate to the USB drive and open it.
- 3 Create a folder on the root folder of the storage card (for example, Music).
Tip You can also create and use folders to organize your music inside the Music folder you have created.
- 4 Copy the music into the folder you have created.
- 5 After copying music, unmount or eject the drive as required by your computer's operating system to safely remove the phone.
- 6 Disconnect the phone from the computer.

To open Music

Press **HOME**, touch the Applications tab, and then touch **Music**. The Music library screen displays.

Music library

Your music is organized into four categories: **Artists**, **Albums**, **Songs**, and **Playlists**. Touch a category to view the list within each.

When inside a category, keep touching the screen until you reach the music you want to play. For example, if you touch **Artists**, you will see a list of artists in alphabetical order. If you touch an artist, the list opens to display the available albums or music. Select an album and the album's song list displays.

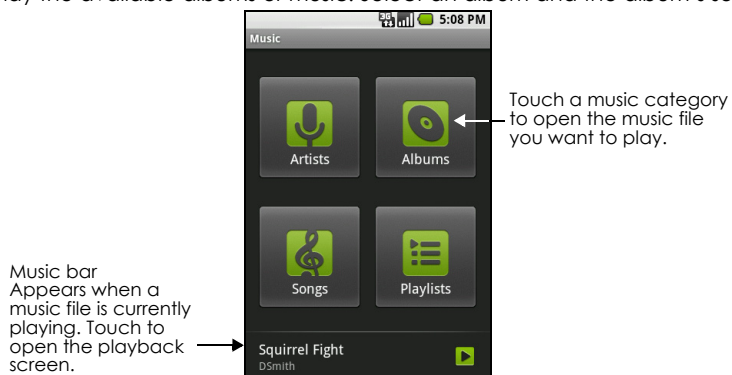

Play music

Touch a song to play it back.

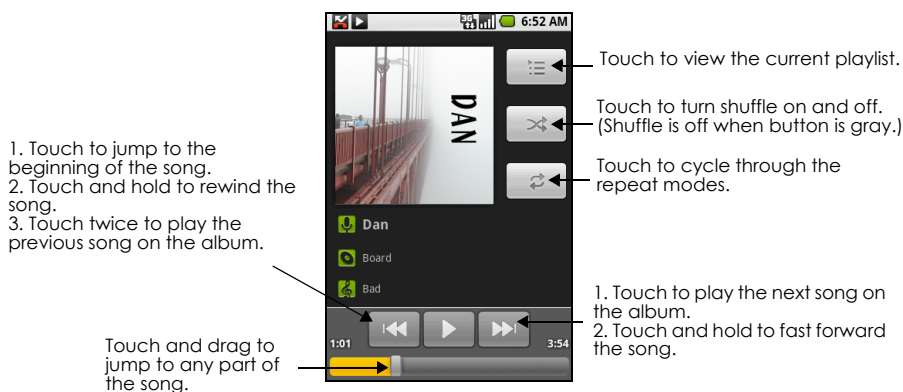

Notes

- Press the **VOLUME UP** or **VOLUME DOWN** button to adjust the playback volume.
- If you are using the provided wired headset to listen to music, press the button to toggle between playing and pausing playback. Press and hold the button to go to the next track on the playlist.

Tip While on the Music library or playback screen, you can play all songs in your library in random order. Press **MENU**, then touch **Party shuffle**. The first randomly selected song will play. To turn off Party shuffle, press **MENU**, then touch **Party shuffle off**.

Use playlists

Use playlists to organize your music files. You can create as many playlists as you want on your phone.

To create a playlist

- 1 Touch a category on the Music library screen.
- 2 In the list that appears, use the **TRACKBALL** to navigate to the artist, album, or song that you want to add in the playlist.
- 3 Touch and hold the artist, album, or song, then touch **Add to playlist** on the options menu.
- 4 In the Add to playlist window, touch **New**.
Tip If you want to add the artist, album, or song to an existing playlist, touch the playlist's name in the Add to playlist options menu.
- 5 Enter the name for your new playlist and then touch **Save**.

To manage your playlists

- 1 Go to the Music library screen and then touch **Playlists**.
- 2 Do one of the following:
 - To play the songs in a playlist, touch the playlist name.
 - To delete a playlist, touch and hold the playlist, then touch **Delete**.
 - To rearrange the songs or remove a song in a playlist, touch and hold the playlist, then touch **Edit** on the options menu. Touch and hold  before the song you want to move, drag it to its new position, then release.
 - To delete a song in a playlist, touch and hold the song, then touch **Remove from playlist**.
 - To rename a playlist, touch and hold the playlist, then touch **Rename** on the options menu. Enter the new playlist name, then touch **Save**.

Note The **Recently added** playlist is a system playlist and cannot be deleted or renamed.

To import a playlist

You can create playlists on your computer, then save these on your storage card. Music can access the following playlist formats: M3U, WPL, and PLS.

- 1 On your computer, open a text file for editing.
- 2 On separate lines, enter all the music file names you want to include in your playlist.

Notes

- The names you list in the file should be the names that appear when you view the contents of your storage card through your computer's file system, not the names that appear in the list of songs on your phone.
 - Your phone will simplify the names and will not include track numbers or file extensions (for example, .mp3).
- 3 Save the playlist file using .m3u as the file name extension (for example, MyMusic.m3u).
 - 4 Copy the playlist file to the Music folder on the storage card. Follow the instructions in "To copy music into the storage card" section earlier in this chapter.
Tip It is recommended that you create a **Playlist** folder inside your **Music** folder in the storage card to hold all your playlist files.

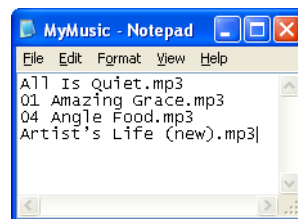

Set a song as ring tone

You can use songs as your phone ring tone.

- 1 From the Music library, navigate to the song that you want to use as ring tone.
- 2 Touch and hold the song, then touch **Use as phone ringtone** on the menu. The song is set as your default incoming call ring tone.

To check if the song was added as a ring tone

- 1 Press **HOME**, press **MENU**, and then touch **Settings**.
- 2 On the Settings screen, touch **Sound & display** > **Phone ringtone**. The song should be listed as an option.

Delete music on the storage card

You can delete music files on the storage card.

- 1 On the Music Library screen, touch **Artists**, **Album**, or **Songs**.
- 2 Touch and hold the artist, album, or song you want to delete, then touch **Delete** on the options menu.
- 3 When prompted, touch **OK**.

9 Using Android Market™

9.1 Using Android Market

Android Market provides direct access to useful applications and fun games which you can download and install on your phone. Android Market also allows you to send feedback and comments about an application, or flag an application that you find objectionable or incompatible with your phone.

To open Android Market

- 1 Press **HOME**, touch the Applications tab, and then touch **Market**.

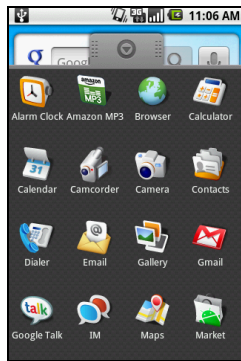

Touch the Market icon to find cool applications to download and install.

- 2 When you open Android Market for the first time, the Terms of Service window will appear. Touch **Accept** to continue.



9.2 Getting help

If you ever need help or have questions about Android Market, press **MENU** and touch **Help**. The Browser will take you to the Android Market Help webpage.

9.3 Finding applications

The Android Market home page provides several ways to find applications. It showcases featured applications and includes a list of item applications by category, a list of games, a link to search, and a link to My downloads.

Scroll horizontally through the featured items or select a category to browse its contents, then select a subcategory. Within each subcategory you can select to view items sorted **By popularity** or **By date**.



Note All items in a subcategory are listed in each tab; those in the **By popularity** tab are sorted from most popular to least popular, and those in the **By date** tab are sorted from newest to oldest

9.4 Installing an application

To install and open an application

- 1 Navigate to the item you want to download, and select it.
- 2 In the item details screen, read more about the application, including its cost, overall rating, and comments by users. If you scroll down to the **About the developer** section, you can view more applications by this developer, visit the developer's website, and send the developer an email message.

Important Press **MENU** and select Security permissions to view the functions and data this item can access on your phone.

Scroll down to view more of this developer's applications or to email the developer.

Touch and hold a comment to let you report a comment as spam.

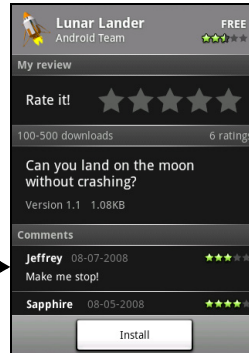

More info about item

User comments about item

- To install the item, select either **Install** (if item is free) or **Buy**, whichever appears. For instructions on how to purchase an application, refer to "Purchasing an application" on page 97.
Important If the application requires either access to any of your data or control of any functions on your phone, Market tells you what the application can access.
Read it carefully! Be especially cautious with applications that have access to many functions or a significant amount of your data. Once you select **OK** on this screen, you are responsible for the results of using this item on your phone. Touch **OK** if you agree to the conditions of the application.
- To check the progress of the download, open the notifications window. Most applications are installed within seconds. If you want to stop downloading the item, touch **Cancel download**.

Download progress appears in the Ongoing section of the notifications window.

Once downloaded and installed, a notification appears.

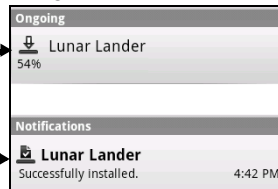

- After the item is downloaded and installed on your phone, the content download icon  appears in the notification area of the status bar.
 - On the Android Market screen, touch **My downloads**.
 - Touch the installed application in the list, then touch **Open**.
- Tip** You can also find the icon of the installed application on the Applications tab.

9.5 Purchasing an application

If an application has a price associated with it, you have to buy it before you can download it. You can try it out for 24 hours. Your credit card will be charged unless you ask for a refund within 24 hours of purchase.

You pay for an application only once. You can uninstall it and download it again later without having to pay for it again. In addition, if you have multiple Android phones that use the same Google Account, you can download the purchased application to all of them at no additional cost.

-
- 1 Touch the application you want to buy.
 - 2 At the bottom of the screen, touch **Buy**.
 - 3 If you are making a purchase for the first time, log in to Google Checkout™ payment and billing service.
If you do not have a Google Checkout account, fill out the form. Google Checkout is a fast, secure, and convenient way to purchase items from your phone. To learn more about Google Checkout, see <https://checkout.google.com>.
Important! Your phone remembers your Google Checkout password, so set up a screen lock to secure your phone. Refer to "Protect your phone with a screen lock" on page 102 for more details.
 - 4 If your Google Checkout account has multiple credit card accounts, select the account that you want to use.
 - 5 Select the **Terms of Service** link and read the document. When you are done, press **BACK**.
 - 6 If you agree with the terms of service for Google Checkout, select the check box.
 - 7 Touch **Buy now** at the bottom of the screen.
Android downloads the application and takes you back you to the Android Market Home. When the download and installation are complete, your status bar displays .

Request a refund

If you are not satisfied with the application, you can ask for a refund within 24 hours of the purchase. Your credit card will not be charged and the application will be removed. If you change your mind, you can install the application again, but you will not be able to request a refund.

To get a refund and remove an application

- 1 In Android Market Home, touch **My downloads**.
- 2 Touch the application that you want to uninstall.
- 3 In the **Uninstall & refund** dialog box, touch **OK**. If the dialog box does not appear, your trial period has expired.
- 4 In the survey form, select the answer that best matches your reason, and touch **OK**.

9.6 Managing your applications

From the Android Market Home, touch **My downloads** to view your downloaded items. From any of the Android Market screens, press **MENU** and touch **My downloads** to go to the screen.

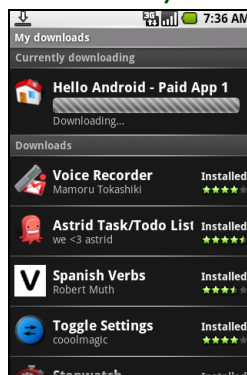

9.7 Uninstalling an application

To uninstall an application

You can uninstall any application that you have downloaded and installed from Android Market.

- 1 On the My downloads screen, touch the application you want to uninstall, then touch **Uninstall**.
- 2 When prompted, touch **OK** to remove the application on your phone.
- 3 Choose the reason for removing the application, then touch **OK**.

10 Managing Your Phone

10.1 Changing Basic Settings

Set the date, time zone, and time

By default, your phone automatically uses the network-provided date, time zone, and time.

To manually adjust the date, time zone, and time

- 1 Press **HOME > MENU**, and then touch **Settings**.
- 2 Scroll down the screen, then touch **Date & time**.
- 3 Clear the **Automatic** check box.
- 4 Touch **Set date**. On the Change date window, touch **+** or **-** to adjust the date, month, and year, then touch **Set** when finished.
- 5 Touch **Set time zone**, then select the time zone in the list. Scroll down the list to view more time zones.
- 6 Touch **Set time**. On the time window, touch **+** or **-** to adjust the hour and minute, then touch **AM** to change to **PM** or vice versa. Touch **Set** when finished.
- 7 Select the **Use 24-hour format** check box to toggle between using a 12-hour or a 24-hour format.
- 8 Touch **Select date format** then select how you want dates to display on your phone. The selected date format also applies to the date displayed in the Alarm Clock.

Note For details on how to set an alarm, refer to "Using Alarm Clock" on page 50.

Display settings

To adjust the screen brightness

- 1 Press **HOME > MENU**, and then touch **Settings**.
- 2 Touch **Sound & display**, scroll down the screen, then touch **Brightness**.
- 3 Drag the brightness slider to the left to decrease or to the right to increase the screen brightness.
- 4 Touch **OK**.

To adjust the time before the screen turns off

After a period of inactivity, the phone screen turns off to conserve battery power. You can set the idle time before the screen turns off.

- 1 Press **HOME > MENU**, and then touch **Settings**.
- 2 Touch **Sound & display**.
- 3 Scroll down the screen, then touch **Screen timeout**.
- 4 Touch the time before the screen turns off.

Tip To turn off the screen quickly, press the **END CALL/POWER** button.

To prevent the screen orientation from automatically changing

By default, the screen orientation automatically adjusts depending on how you hold the phone.

- 1 Press **HOME > MENU**, and then touch **Settings**.
- 2 Touch **Sound & display**.
- 3 Scroll down the screen, then clear the **Orientation** check box.

To keep the screen on while charging the phone

You can keep the phone from turning off the screen while you are charging the phone.

- 1 Press **HOME > MENU**, and then touch **Settings**.
- 2 Touch **Applications > Development** and then select the **Stay awake** check box.

Ringer settings

To change the ring tone

- 1 Press **HOME > MENU**, and then touch **Settings**.
- 2 Touch **Sound & display > Phone ringtone**.
- 3 Touch the ring tone you want to use, then touch **OK**. The ring tone briefly plays when selected.

Tip You can use *.wav, *.mid, *.mp3, *.wma, or other types of sound files that you downloaded from the Internet or copied from your computer as ring tones. For a complete list of supported audio file formats for ring tones, refer to "Specifications" in the Appendix.

To enable touch tones

You can set the phone to play a sound when you are using Dialer phone pad and/or touching the screen.

- 1 Press **HOME > MENU**, and then touch **Settings**.
- 2 Touch **Sound & display**, then scroll down the screen.
- 3 Select the **Audible touch tones** and/or **Audible selection** options.

To choose the notification ring tone

You can select the ring tone to play when your phone receives new notifications.

- 1 Press **HOME > MENU**, and then touch **Settings**.
- 2 Touch **Sound & display > Notification ringtone**.
- 3 Select your preferred notification ring tone in the list and then touch **OK**.

Phone services

Your phone can directly link to the mobile phone network, and enable you to access and change the settings of various phone services for your phone. Phone services may include Call Forwarding, Call Waiting, Voicemail, and more. Contact your wireless service provider to find out about the availability of phone services for your phone.

To access and change the phone services settings

- 1 Press **HOME > MENU**, and then touch **Settings**.
- 2 Touch **Call settings**.

Note For more information about the phone services on your phone, refer to "Adjusting Phone Settings" on page 43.

To enable data roaming

Data roaming lets you connect to your wireless service provider's partner networks and access data services when you are out of your wireless service provider coverage area.

-
- 1 Press **HOME > MENU**, and then touch **Settings**.
 - 2 Touch **Wireless controls > Mobile networks**.
 - 3 Select the **Data roaming** option.

Important Accessing data services while roaming may incur significant charges. Inquire the data roaming tariffs with your wireless service provider before enabling data roaming.

Language settings

You can change the operating system language of the phone.

To change the language of the operating system

- 1 Press **HOME > MENU**, and then touch **Settings**.
- 2 Touch **Locale & text > Select locale** and then select the language you want to use.

10.2 Protecting Your Phone

Protect your SIM card with a PIN

You can protect your SIM card from unauthorized use by assigning a PIN (personal identification number).

To enable the SIM card PIN

- 1 Press **HOME > MENU**, and then touch **Settings**.
- 2 Touch **Security & location**, scroll down the screen, then touch **Set up SIM card lock**.
- 3 Select the **Lock SIM card** option.
- 4 Enter the default SIM card PIN using the keyboard, then touch **OK**.
- 5 To change the SIM card PIN at any time, touch **Change PIN code**.

Tip Emergency calls can be placed at any time, without requiring a PIN.

To restore a SIM card that has been locked out

If you enter the wrong PIN more times than the maximum number of attempts allowed, your SIM card will become "PUK-locked." You need a new PUK code to restore access to the device. This code may have been provided by your operator when you received your SIM card.

Touch **Emergency Dial** and enter the following sequence on the keypad:

****05*[PUK code]*[new PIN]*[new PIN]#**

For example, if your PUK code is 888888 and you would like to reset the PIN on your SIM card to 7777, enter the following into Emergency Dial: ****05*888888*7777*7777#**

Protect your phone with a screen lock

You can further secure your data by locking the screen and/or requiring a screen unlock pattern every time your phone is turned on or every time it wakes up from sleep mode (screen is off).

To lock the screen

Press the **END CALL/POWER** button. Locking the screen prevents accidental screen touches when the phone is in your bag, purse, or pocket.

Note To unlock the screen, press one of the buttons in front of the phone, and then press **MENU** and enter your screen unlock pattern.

To create and enable the screen unlock pattern

You can increase the security of your phone by creating a screen unlock pattern. When enabled, you have to draw the correct unlock pattern on the screen to unlock the phone's control buttons and touch screen.

- 1 Press **HOME > MENU**, and then touch **Settings**.
 - 2 Touch **Security & location > Set unlock pattern**.
 - 3 Read the information on the screen, then touch **Next**.
 - 4 Study the example pattern on the screen, then touch **Next**.
 - 5 Draw the screen unlock pattern by connecting at least four dots in a vertical, horizontal and/or diagonal direction. Lift your finger from the screen when finished.
- Note** You must slide your finger on the screen to create the pattern and not touch individual dots.
- 6 The phone records the pattern. Touch **Continue**.
 - 7 When prompted, draw the screen unlock pattern again, then touch **Confirm**.

Tip Clear the **Use visible pattern** check box if you do not want the unlock pattern to display on the screen when you unlock it.

Note To change your unlock screen pattern, press **HOME**, then press **MENU**, and then touch **Settings > Security & location > Change unlock pattern**.

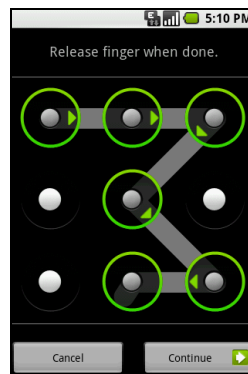

When you fail to draw the correct unlock pattern on the screen after five attempts, you will be prompted to wait for 30 seconds before you can try again. If you forgot your screen unlock pattern, touch **Forgot pattern**. You will be prompted to sign in using your Google Account name and password, and create a new screen unlock pattern before the Home screen displays.

10.3 Managing Memory

To see how much phone memory is available for use

- 1 Press **HOME > MENU**, and then touch **Settings**.
- 2 Scroll down the screen, then touch **SD card & phone storage**. The available phone memory is displayed in the Internal phone storage section.

To see the available storage card space

- 1 Press **HOME > MENU**, and then touch **Settings**.
- 2 Scroll down the screen, then touch **SD card & phone storage**. The total and available storage card space display in the **SD card** section.

To clear application cache and data

- 1 Press **HOME > MENU**, and then touch **Settings > Applications > Manage applications**.
- 2 In the Manage applications list, touch the application whose cache and/or data you want to delete.

Tip Press **MENU** to bring up sort and filter options.

- 3 In the Application info screen, touch **Clear data** and/or **Clear cache**.

To uninstall applications not from Android Market

You cannot uninstall applications that are preinstalled on the phone.

- 1 Press **HOME > MENU**, and then touch **Settings > Applications > Manage applications**.
- 2 On the Manage applications screen, touch the application you want to uninstall.
- 3 On the Application info screen, touch **Uninstall**.

To free up more phone memory or storage card space

If your phone is running low on memory, you can try the following:

- In Browser, clear all temporary Internet files and Browser history information. Refer to "Using Browser" on page 69 for more details.
- Uninstall programs you downloaded from Android Market that you no longer use. Refer to "To uninstall an application" on page 99 for more details.

10.4 Software Updates

Google might send new or updated versions of your phone's operating system via over-the-air (OTA) updates. When your phone receives an OTA update, it will automatically connect to the Internet using your data connection (3G, GPRS, EDGE, or Wi-Fi) and will download the software update.

Note If you are roaming or if you clear the **Background data** check box (described in the next section), you will not receive updates.

10.5 Synchronizing Google Applications™

Google Applications on your phone, such as Google Mail, Calendar, and Contacts, give you access to the same personal information (emails, events, and contacts) that you add, view, and edit on your computer using Google Mail or Calendar. Synchronize the Google application information you want to keep up-to-date.

To select which application to synchronize

- 1 Press **HOME > MENU**, and then touch **Settings > Data synchronization**.
- 2 Select the **Background data** and **Auto-sync** check boxes and then select the Google Applications check boxes you want to be automatically synchronized.
Tip Clear the **Background data** check box to help save battery power and to lower data connection usage.

Note If the **Auto-sync** check box is not selected, you need to touch the Google application in the list to synchronize it.

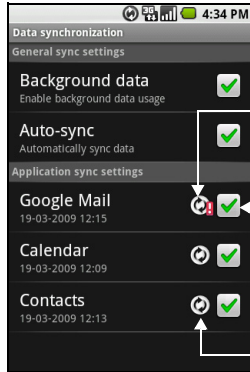

Indicates that there is a problem with data synchronization. Check your data connection and try again.

Touch to include or exclude the application from automatic synchronization.

The arrows move clockwise when data is being synchronized.

To stop synchronization

During synchronization, press **MENU**, then touch **Cancel sync** to stop synchronization.

10.6 Resetting the Phone

Resetting the phone deletes all data, including downloaded applications, and resets the phone back to its initial state—the state before you turned on the phone for the first time.

Important Make sure to back up important data you have on the phone before you perform a factory data reset.

Note For Android Market applications that you purchased, you can download and install them again on the phone. Refer to "Purchasing an application" on page 97 for more details.

To reset the phone

- 1 Press **HOME** > **MENU**, and then touch **Settings**.
- 2 Scroll down the screen, then touch **SD card & phone storage**.
- 3 Navigate to the Internal phone storage section, then touch **Factory data reset**.
- 4 On the Factory data reset screen, touch **Reset phone**. If prompted, enter your screen unlock pattern, then touch **Erase everything**.

Tip If your phone hangs or freezes, remove the battery, then wait for a few seconds, and then re-install it. After re-installing the battery, turn on the phone.

11 Appendix

11.1 A.1 Specifications

| | |
|---------------------------|--|
| Processor | Qualcomm® MSM7201A™ 528 MHz |
| Platform | Android™ |
| Memory | ROM: 256 MB RAM: 192 MB |
| Dimensions (LxWxT) | 11 7.7 mm x 55.7 mm x 17.1 mm (4.60 in x 2.16 in x 0.62 in) |
| Weight | 158 g (5.60 ounces) with battery |
| Display | 3.17-inch TFT-LCD flat touch-sensitive screen with 320 x 480 HVGA resolution |
| Networks | HSPA/WCDMA: 2100 MHz Up to 7.2 Mbps down-link (HSDPA) and 2 Mbps up-link (HSUPA) speeds Quad-band GSM/GPRS/EDGE: 850/900/1800/1900 MHz (Band frequency, HSPA availability, and data speed are operator dependent) |
| Device control | Trackball with Enter button |
| Keyboard | Slide-out 5-row QWERTY keyboard |
| GPS | GPS navigation capability with Google Maps™ |
| Connectivity | Bluetooth® 2.0 with Enhanced Data Rate and A2DP for wireless stereo headsets Wi-Fi®: IEEE 802.11b/g HTC ExtUSB™ (11-pin mini-USB 2.0 and audio jack in one) |
| Camera | 3.2 megapixel color camera with auto focus |
| Audio | Built-in microphone and speaker Ring tone formats AAC, AAC+, AMR-NB, MIDI, MP3, WMA, WAV 40 polyphonic and standard MIDI format 0 and 1 (SMF) / SP MIDI |

| | |
|-------------------------|---|
| Battery | Rechargeable Lithium-ion battery Capacity: 1150 mAh Talk time: Up to 350 minutes for WCDMA Up to 406 minutes for GSM Standby time: Up to 402 hours for WCDMA Up to 319 hours for GSM (Approximations based on the phone manufacturer's lab tests.) |
| Expansion slot | microSD memory card (SD 2.0 compatible) |
| AC adapter | Voltage range/frequency: 100 - 240V AC, 50/60 Hz DC output: 5V and 1A |
| Special features | Digital Compass, Motion Sensor |

Note Specifications are subject to change without prior notice.

11.2 A.2 Regulatory Notices

Regulatory Agency Identifications

For regulatory identification purposes, this product is assigned a model number of **DREA110**.

To ensure continued reliable and safe operation of this product, use only the accessories listed below with your **DREA110**.

The Battery Pack has been assigned a model number of **DREA160**.

Note This product is intended for use with a certified Class 2 Limited Power Source, rated 5 Volts DC, maximum 1 Amp power supply unit.

Federal Communications Commission Notice

This device complies with part 15 of the FCC Rules. Operation is subject to the following two conditions: (1) This device may not cause harmful interference, and (2) this device must accept any interference received, including interference that may cause undesired operation.

This equipment has been tested and found to comply with the limits for a Class B digital device, pursuant to Part 15 of the FCC Rules. These limits are designed to provide reasonable protection against harmful interference in a residential installation. This equipment generates, uses, and can radiate radio frequency energy and, if not installed and used in accordance with the instructions, may cause harmful interference to radio communications. However, there is no guarantee that interference will not occur in a particular installation. If this equipment does cause harmful interference to radio or TV reception, which can be determined by turning the equipment on and off, the user is encouraged to try to correct the interference by one or more of the following measures:

- Reorient or relocate the receiving antenna.
- Increase the separation between the equipment and receiver.
- Connect the equipment into an outlet on a circuit different from that to which the receiver is connected.
- Consult the dealer or an experienced radio or television technician for help.

Modifications

The FCC requires the user to be notified that any changes or modifications made to the device that are not expressly approved by High Tech Computer Corporation may void the user's authority to operate the equipment.

Body-worn operation

This device was tested for typical body-worn operations with the back of the phone kept **1.5 cm** from the body. To maintain compliance with FCC RF exposure requirements, use only belt-clips, holsters or similar accessories that maintain a **1.5 cm** separation distance between the user's body and the back of the phone, including the antenna. The use of belt-clips, holsters and similar accessories should not contain metallic components in its assembly. The use of accessories that do not satisfy these requirements may not comply with FCC RF exposure requirements, and should be avoided.

Safety Precautions for Radio Frequency Exposure

- Use only original manufacturer-approved accessories, or accessories that do not contain any metal.
- Use of non-original manufacturer-approved accessories may violate your local Radio Frequency exposure guidelines and should be avoided.

FCC RF Radiation Exposure Statement

- This Transmitter has been demonstrated co-location compliance requirements with Bluetooth and WLAN.
This transmitter must not be co-located or operating in conjunction with any other antenna or transmitter.
- This equipment complies with FCC RF radiation exposure limits set forth for an uncontrolled environment.

Exposure to Radio Frequency (RF) Signals

Your phone contains a radio transmitter and receiver. The radiated output power is far below the international radio frequency exposure limits. These limits are part of comprehensive guidelines and establish permitted levels of Radio Frequency energy for the general population. The guidelines are based on the safety standards previously set by international standards bodies:

- American National Standards Institute (ANSI) IEEE. C95.1-1992
- National Council on Radiation Protection and Measurement (NCRP). Report 86. 1986
- International Commission on Non-Ionising Radiation Protection (ICNIRP) 1996
- Ministry of Health (Canada), Safety Code 6. The standards include a substantial safety margin designed to assure the safety of all persons, regardless of age and health.

The exposure standard for wireless mobile phones employs a unit of measurement known as the Specific Absorption Rate, or SAR. The standard incorporates a substantial margin of safety to give additional protection for the public and to account for any variations in usage.

As with other mobile radio transmitting equipment, users are advised that for satisfactory operation of the equipment and for the safety of personnel, it is recommended that no part of the human body be allowed to come too close to the antenna during operation of the equipment.

Your phone has an internal antenna. Use only the supplied integral antenna. Use of unauthorized or modified antennas may impair call quality and damage your phone, causing loss of performance and SAR levels exceeding the recommended limits as well as result in non-compliance with local regulatory requirements in your country.

To assure optimal phone performance and ensure human exposure to Radio Frequency energy is within the guidelines set forth in the relevant standards; always use your phone only in its normal-use position. Do not touch or hold the antenna area unnecessarily when placing or receiving a phone call. Contact with the antenna area may impair call quality and cause your phone to operate at a higher power level than needed. Avoiding contact with the antenna area when your phone is IN USE optimizes the antenna performance and the battery life.

Tests for SAR are conducted using standard operating positions specified by the FCC with the phone transmitting at its highest certified power level in all tested frequency bands. Although the SAR is determined at the highest certified power level, the actual SAR level of the phone while operation can be well below the maximum value. This is because the phone is designed to operate at multiple power levels so as to use only the power required to reach the network. In general, the closer you are to a wireless base station antenna, the lower the power output. Before a phone model is available for sale to the public, it must be tested and certified to the FCC that it does not exceed the limit established by the government-adopted requirement for safe exposure. The tests are performed in positions and locations (for example, at the ear and worn on the body) as required by the FCC for each model. (Bodyworn measurements may differ among phone models, depending upon available accessories and FCC requirements). For body worn operation, to maintain compliance with FCC RF exposure guidelines, use only original manufacturer approved accessories.

SAR Information

0.619W/Kg@10g (Head)

1.91W/Kg@10g (Body)

Telecommunications & Internet Association (TIA) Safety Information

Pacemakers

The Health Industry Manufacturers Association recommends that a minimum separation of six inches be maintained between a handheld wireless phone and a pacemaker to avoid potential interference with the pacemaker. These recommendations are consistent with the independent research by and recommendations of Wireless Technology Research. Persons with pacemakers:

- Should ALWAYS keep your phone more than six inches from their pacemaker when your phone is turned on.
- Should not carry your phone in a breast pocket.
- Should use the ear opposite the pacemaker to minimize the potential for interference. If you have any reason to suspect that interference is taking place, turn your phone off immediately.

Hearing Aids

Some digital wireless phones may interfere with some hearing aids. In the event of such interference, you may want to consult your wireless service provider, or call the customer service line to discuss alternatives.

Other Medical Devices

If you use any other personal medical device, consult the manufacturer of your phone to determine if they are adequately shielded from external Radio Frequency energy. Your physician may be able to assist you in obtaining this information.

Turn the phone off in health care facilities when any regulations posted in these areas instruct you to do so. Hospitals or health care facilities may be using equipment that could be sensitive to external Radio Frequency energy.

WEEE Notice

The Directive on Waste Electrical and Electronic Equipment (WEEE), which entered into force as European law on 13th February 2003, resulted in a major change in the treatment of electrical equipment at end-of-life.

The purpose of this Directive is, as a first priority, the prevention of WEEE, and in addition, to promote the reuse, recycling and other forms of recovery of such wastes so as to reduce disposal.



The WEEE logo (shown at the left) on the product or on its box indicates that this product must not be disposed of or dumped with your other household waste. You are liable to dispose of all your electronic or electrical waste equipment by relocating over to the specified collection point for recycling of such hazardous waste. Isolated collection and proper recovery of your electronic and electrical waste equipment at the time of disposal will allow us to help conserving natural resources. Moreover, proper recycling of the electronic and electrical waste equipment will ensure safety of human health and environment. For more information about electronic and electrical waste equipment disposal, recovery, and collection points, please contact your local city center, household waste disposal service, shop from where you purchased the equipment, or manufacturer of the equipment.

RoHS Compliance

This product is in compliance with Directive 2002/95/EC of the European Parliament and of the Council of 27 January 2003, on the restriction of the use of certain hazardous substances in electrical and electronic equipment (RoHS) and its amendments.

Index

Numerics

3G 67

A

Adjusting keyboard settings 35

Airplane Mode 43

Alarm

- set an alarm 50

Alarm Clock 50

Android Market 95

- finding applications 96
- getting help 96
- installing an application 96
- installing items 96
- managing your applications 98
- open 95
- purchasing an application 97
- request a refund 98
- uninstalling an application 99

Applications

- on your phone 29
- tab 29

B

Back cover

- remove 17

Backlight

- adjust brightness 100

Basic settings 100

Battery 17, 18

- charge battery 20
- install 19
- remove 19

Bluetooth

- about 74
- disconnect 75
- modes 74

Bookmarks 73

- a web page 73
- edit 73
- open 73

Browser 69

- change the settings 73
- open 69
- to copy text 71
- to find text 71
- to switch browser windows 70

C

Calendar 48

- create events 48
- open 48

Calendar views 49

Call Log

- clear 42

- using 41

Call settings

- adjust the call settings 43

Calling

- from the Call log tab 37
- from the Contacts tab 37
- from the Favorites tab 38

Camcorder 84

Camera

- about 84
- capture modes 84
- Copying to storage 86
- Post capture 85
- shoot videos 85

Chat

- close 65
- sign out 66
- switch chats 65

Conference call 41

Connect phone to Internet

- ways of connecting 67

Contact

- send an email 47

Contacts

- about 43
- add new 44
- call 46
- contacts list 43
- edit 45, 46
- send a text or picture message 46

D

Data roaming 101

Date 100

Display settings 100

Downloads 71

E

EDGE 67

Email 62

- create and send 58
- open 60
- receive and read 59
- search 60
- set notifications 61

Emergency call 36

Events

- create 48

Extended Home screens 24

External email accounts

- add 62
- compose and send emails 62
- delete a message 63
- delete an account 63

F

- Folders 25
- Format the SD card 31
- Friends list 65
 - find 65
 - pin 65

G

- Gallery
 - about 86
 - browse through pictures 87
 - crop 88
 - open 86
 - rotate 87
 - zoom in or out on a picture 87
- Getting around your phone 21
- Google Mail 58
 - create and send emails 58
 - open 58
- Google password 23
- Google Talk 63
 - add a friend 64
 - change the settings 66
 - change your status 64
 - friends list 65
 - sign in automatically 66
 - sign out 66
 - view and accept invitations 64
- GPRS 67
- GPS satellites 76

H

- Home page 69
- Home screen
 - about 24
 - customize 25
 - extended Home screens 24

I

- illustrations
 - Home screen 95
- Inside the box 16
- install
 - item from Android Market 96
- International call 36
- Internet 67

K

- Keyboard
 - hardware 15, 32
 - onscreen 34
- Keyboard buttons
 - ALT key 33
 - menu 33
 - search 32
 - shift key 33

L

- Language settings 102
- Links 71

- Location source 76

M

- Making Calls 36
- Map mode 78
 - Map mode 79
 - Satellite mode 79
 - Street View 79
 - Traffic mode 79
- Maps
 - about 76
 - location source 76
 - navigate 78
 - open 76
 - search 77, 78
 - view 78
 - zoom in or out 78
- Memory 103, 104
- Memory card
 - install 19
 - remove 20
 - remove while the phone is on 31
- Message draft 55
- Message signature 59
- Message threads 55
 - delete 56
 - open 55
- Messaging 52
 - open 52
- Missed call 42
- MMS settings 57
- Mobile indicators 66
- Multiple calls 41
- Music
 - delete music on memory card 94
 - Music Library 91
 - open 91
 - play music 92
 - playlists 92
 - set as ring tone 93
 - supported file formats 91
- Music Library 91
- Mute the microphone 40

N

- Notification LED 28
- Notification ring tone 101
- Notifications Panel 27

O

- Onscreen keyboard 34

P

- Phone controls 21
- Phone services 101
- Phone views
 - back panel 15
 - front panel 14
 - left and right panels 16
- Picture message 52
 - reply 56

- settings 57
- view 56

PIN 102

Playlists

- about 92
- create 93
- manage 93

R

Regulatory notices 107

Resetting the Phone 105

Ring tone 93

- change 101

Ringer settings 101

Roaming 101

S

Safety information 3

Screen lock 102

Screen unlock pattern 103

Settings 29

Shortcuts 25

SIM card 17

- install 17
- PIN 102
- remove 18

SMS settings 57

Speakerphone 40

Specifications 106

Status icons 26

Synchronizing Google Applications 104

T

Take pictures 85

Text message 52

- create and send 52
- reply 56
- settings 57

Time 100

Time zone 100

To prevent the screen orientation from automatically changing 101

To remove a Home screen item 25

To reposition a Home screen item 25

Touch tones 101

Trackball 22

Turn off the display 23

Turn phone function on and off 43

Turn power on and off 22

U

USB drive 31

V

Videos 90

Voice call

- answer call 39

Voice Dialer 37

Voicemail 38

Volume

- adjust 30
- media volume 30
- ringer volume 30

W

Wallpaper 25

Wallpapers 25

Web applications 72

Web history 71

Web page

- go to a web page 69
- navigate 69
- set your home page 69
- view multiple pages 70
- zoom in or out 70

Web pages

- view 69

Widgets 25

Wi-Fi 67

Y

YouTube

- about 90
- open 90
- watch videos 90

YouTube - search videos 91

YouTube - upload videos 91