

SAR REDUCTION PADS

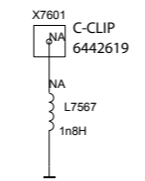

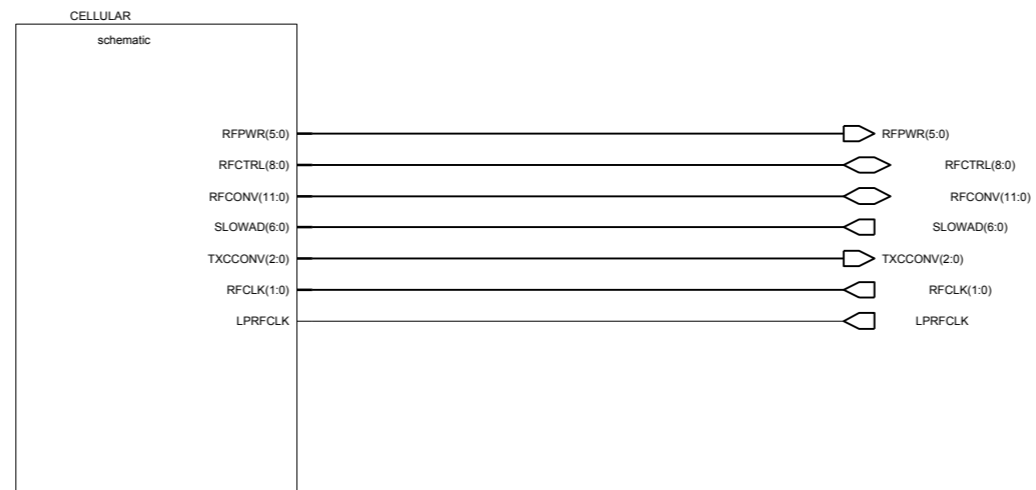



BLUETOOTH

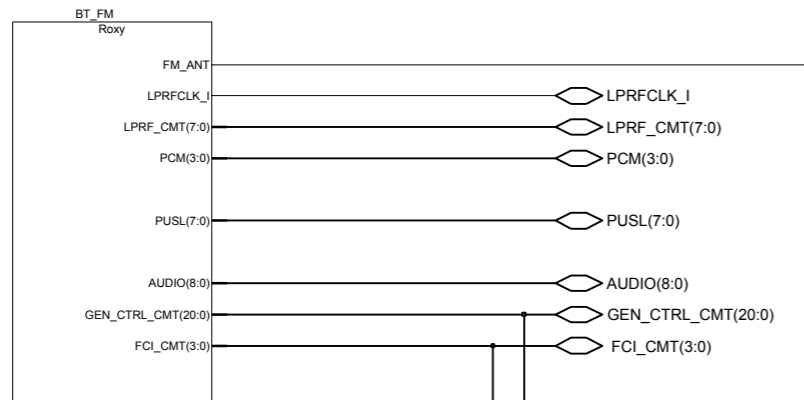

- GPS\_CMT(2:0)
- IRDA\_CMT(2:0)
- USB\_AC(7:0)
- HS\_USB(12:0)
- WLAN\_CMT(4:0)
- RFID\_CMT(1:0)
- MMC(14:0)

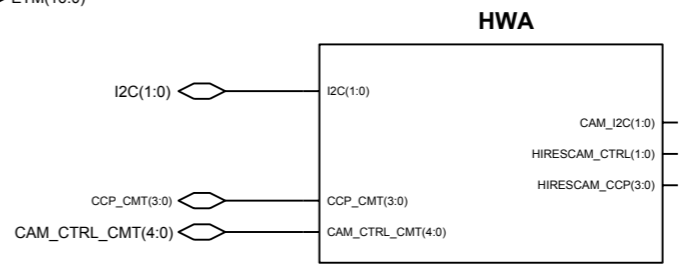
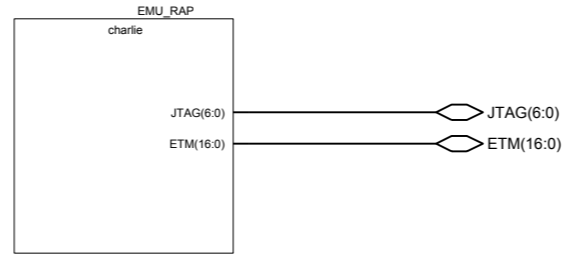
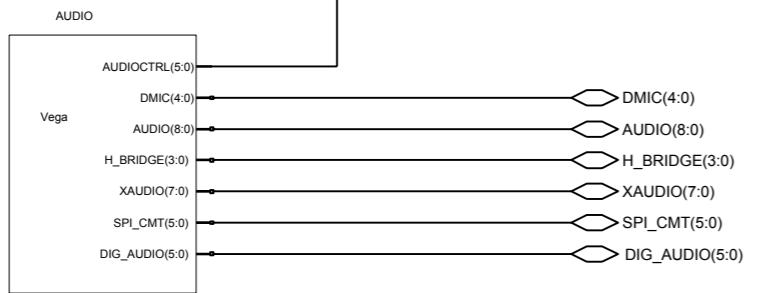
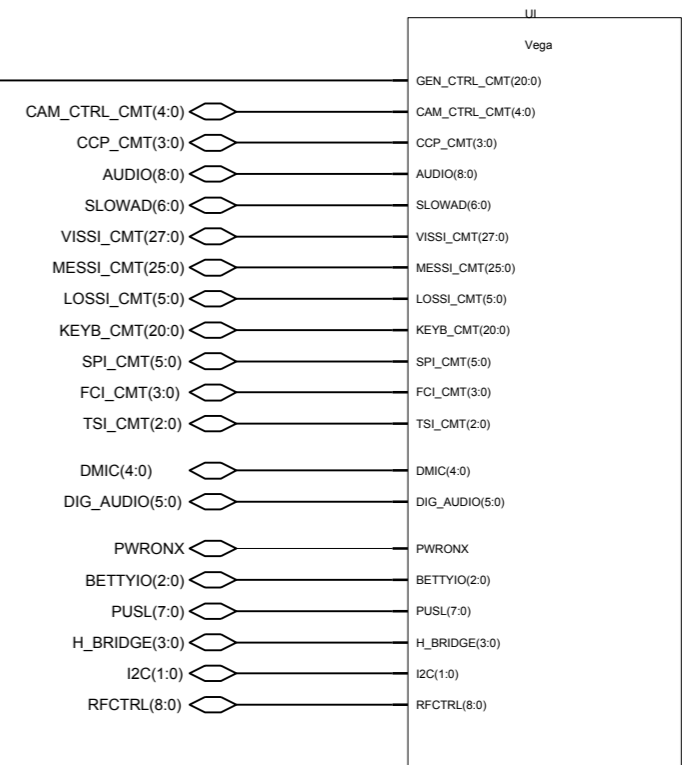
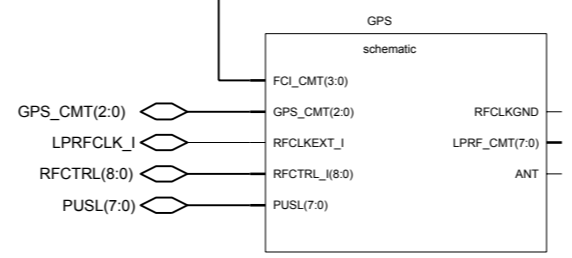
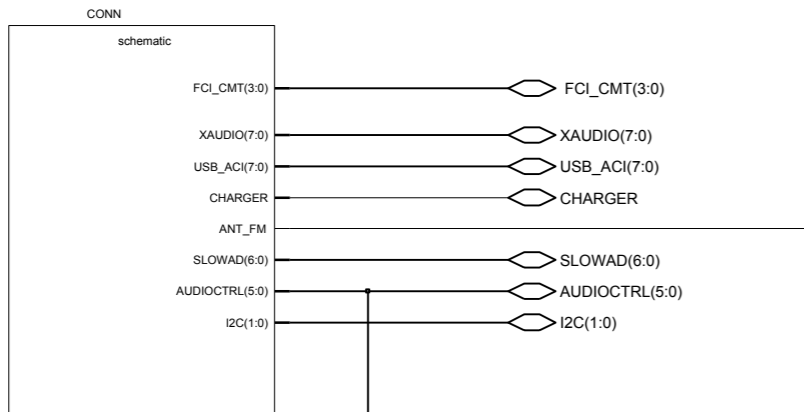

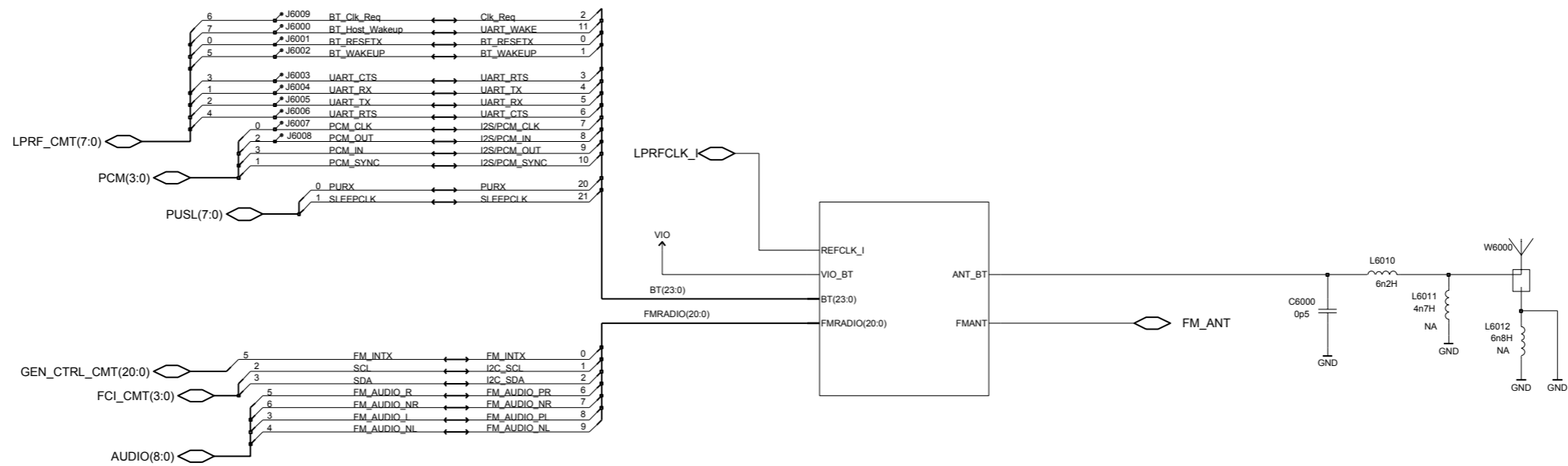

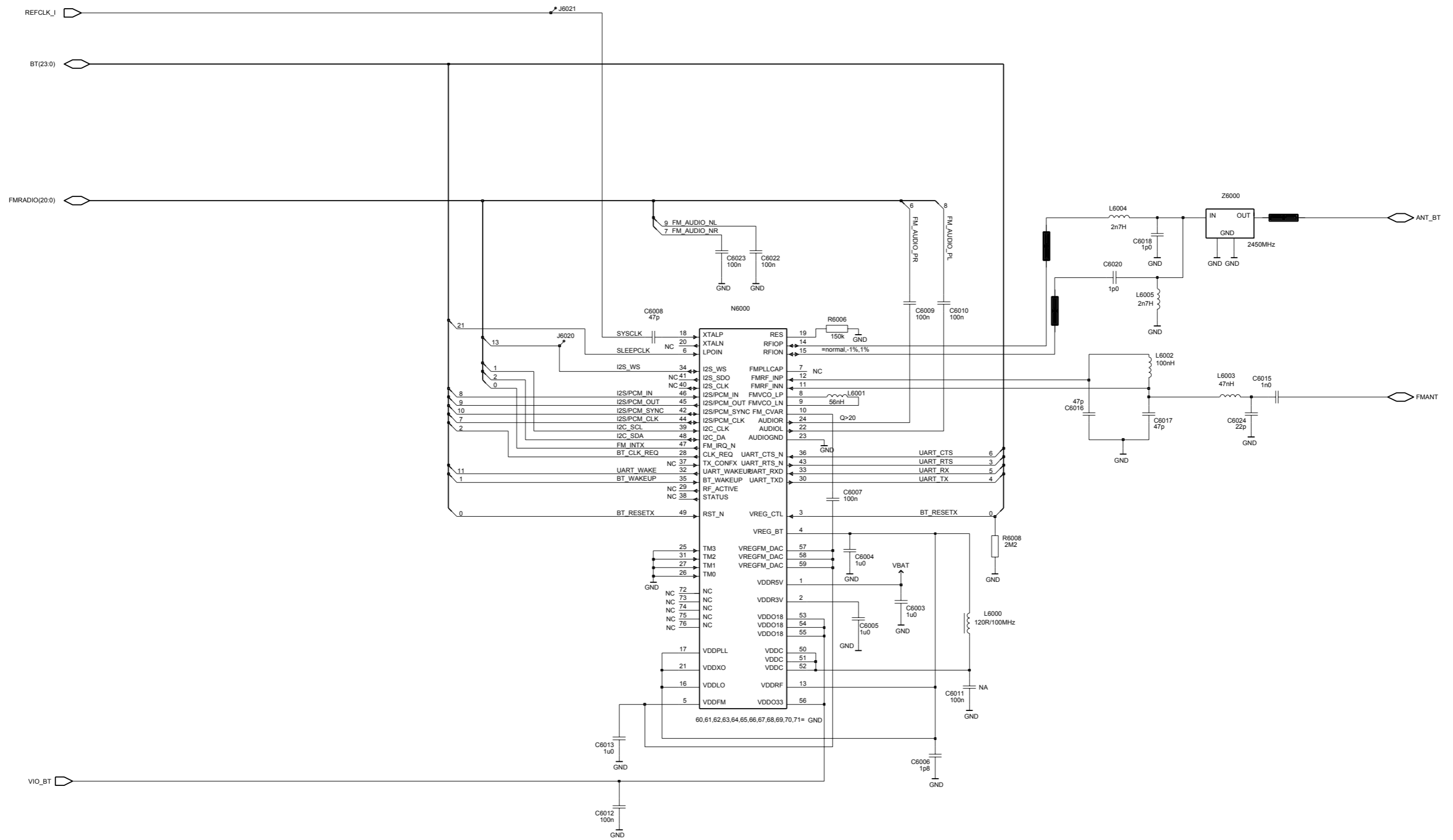

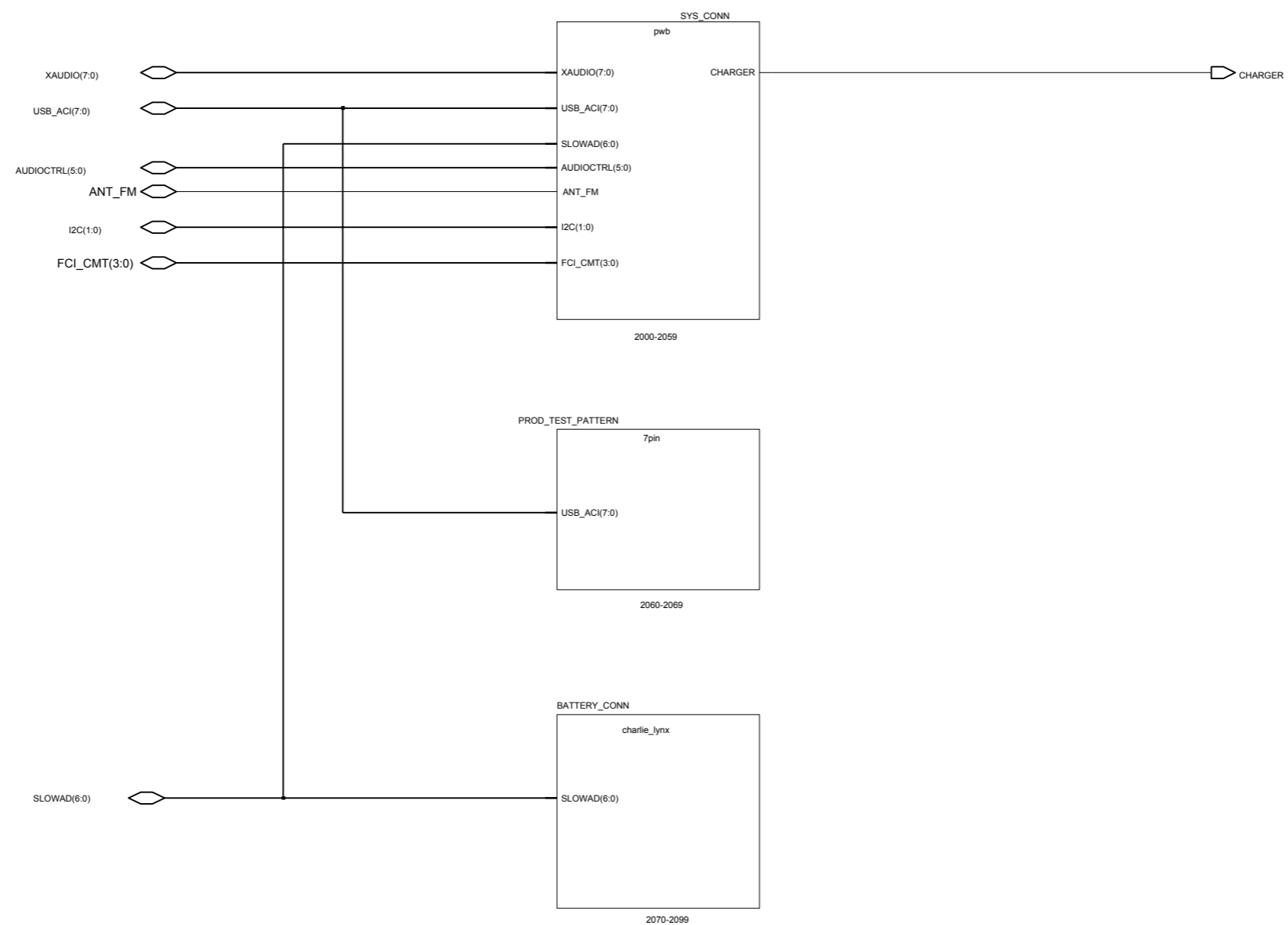

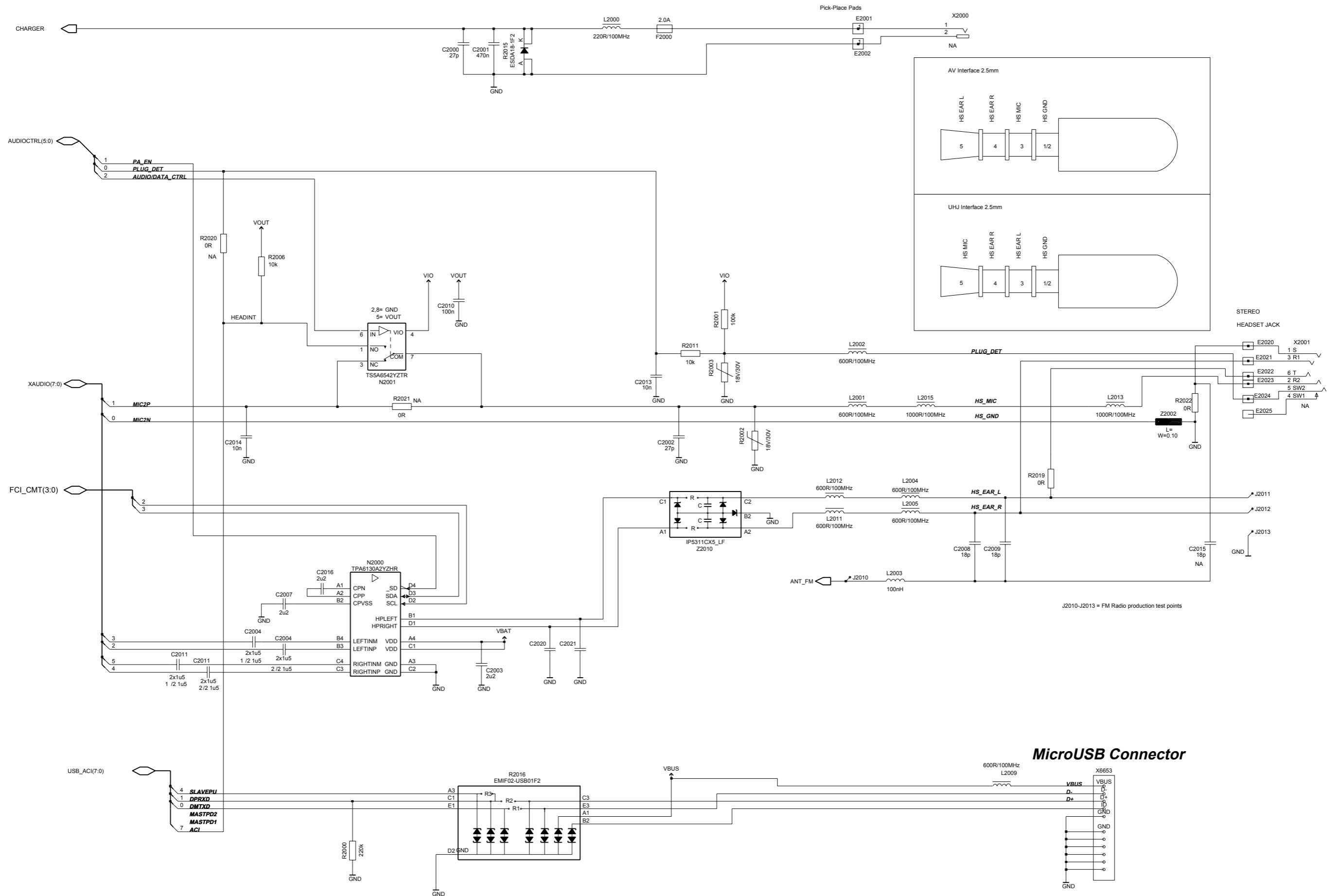

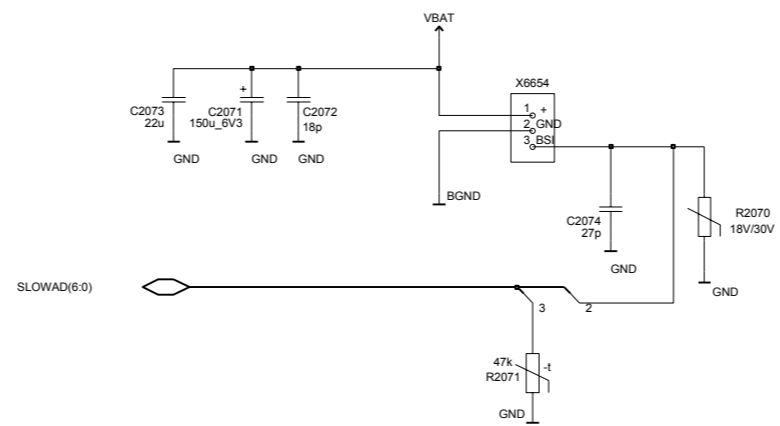

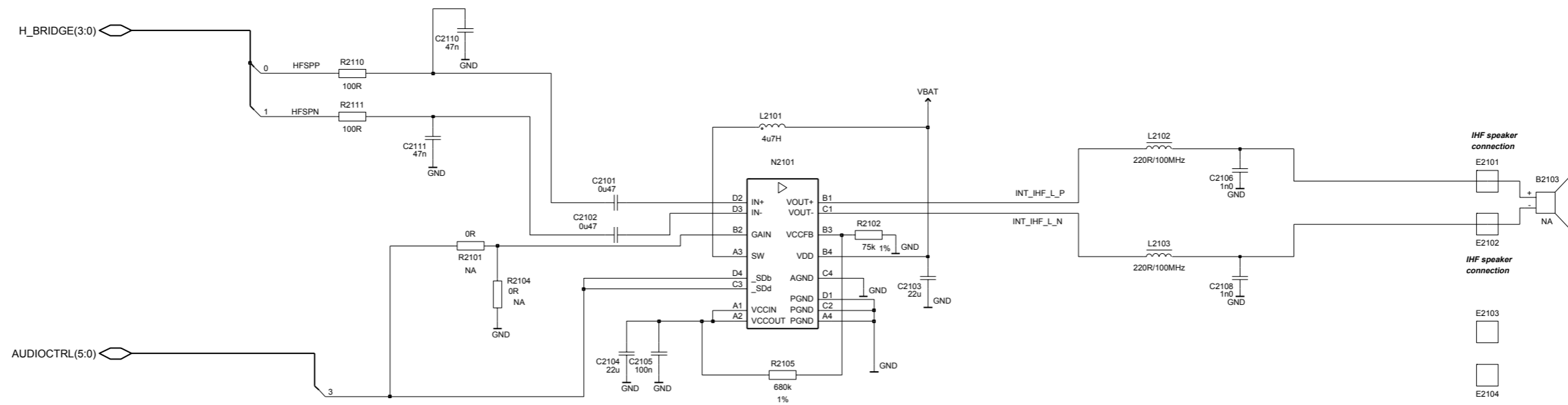

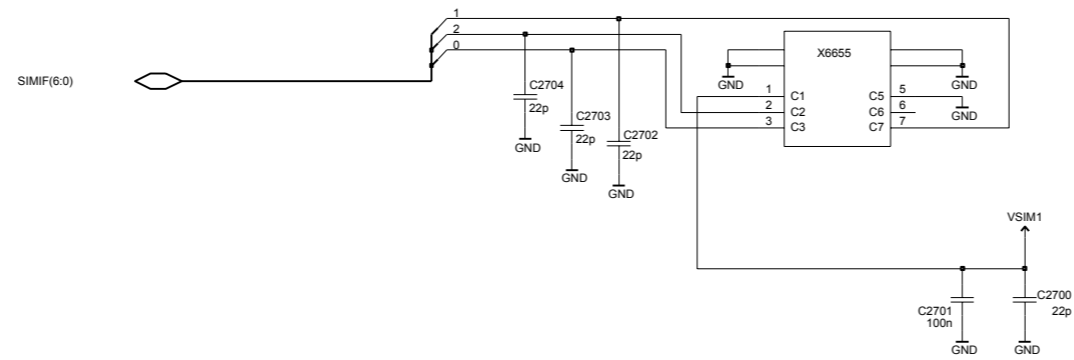

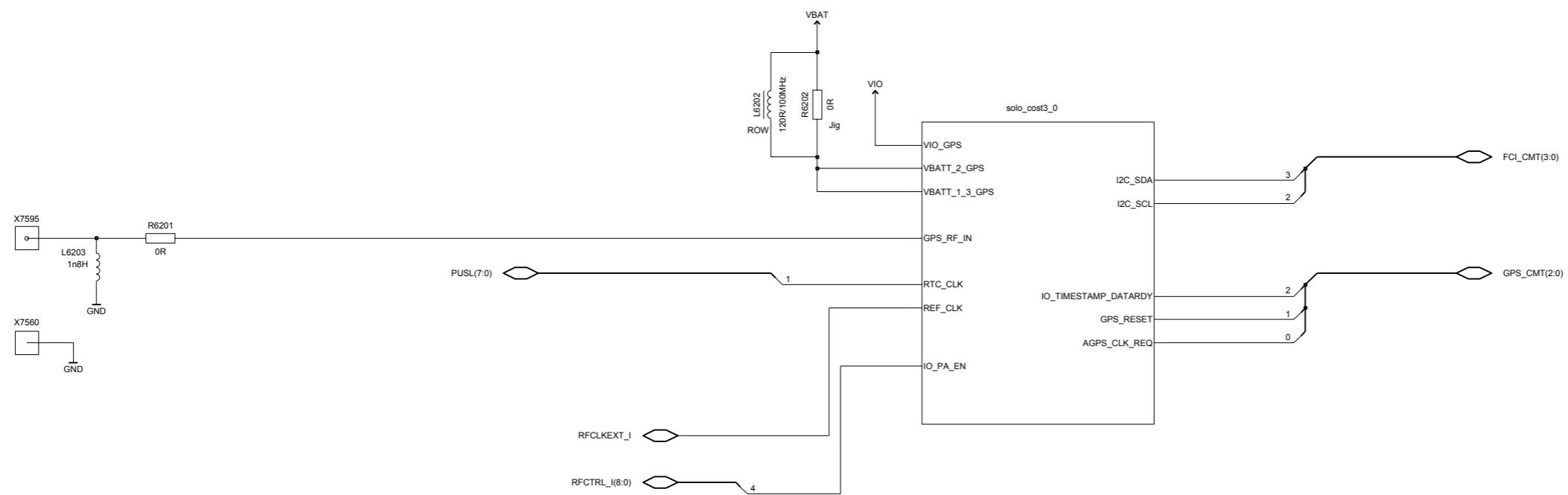

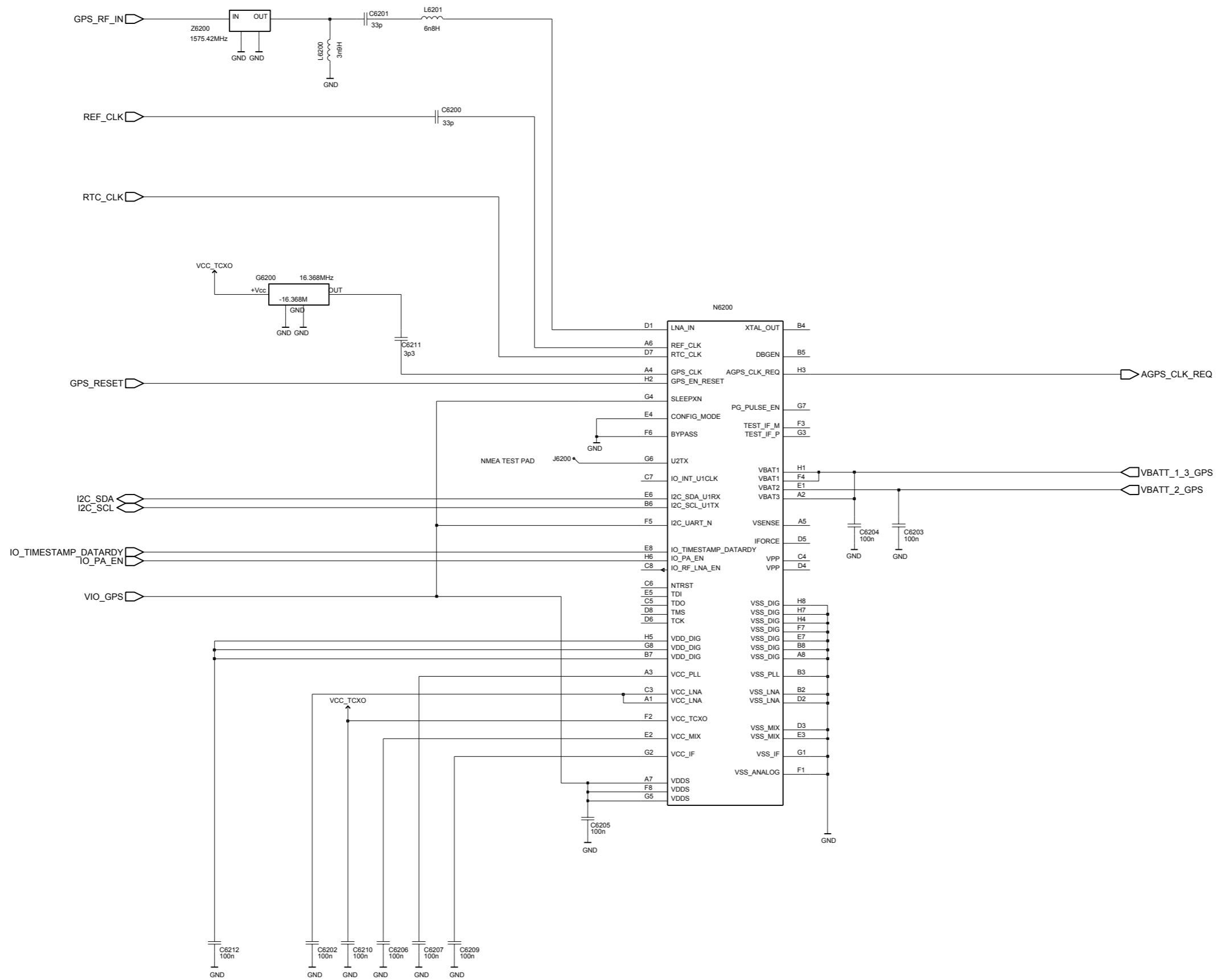



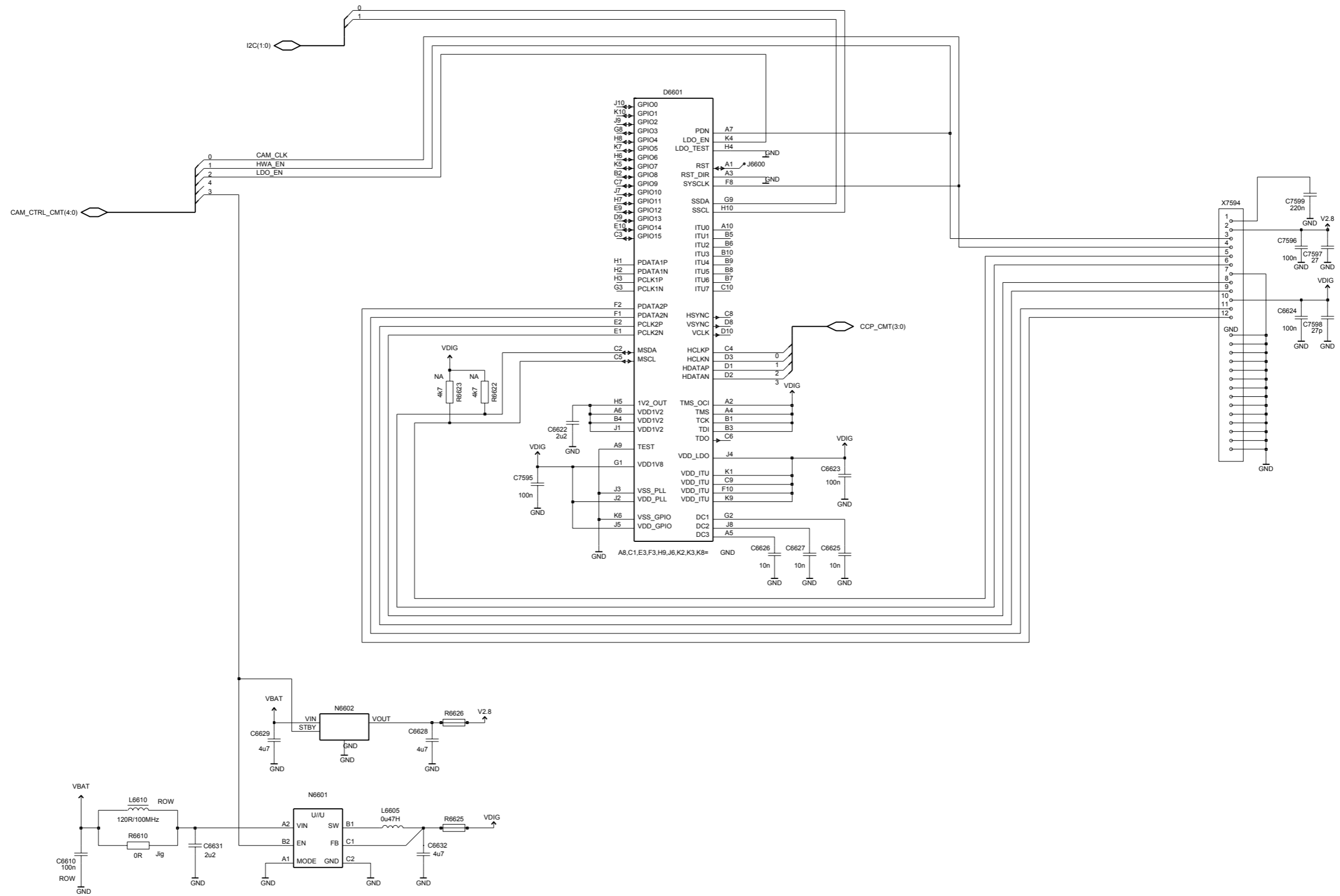

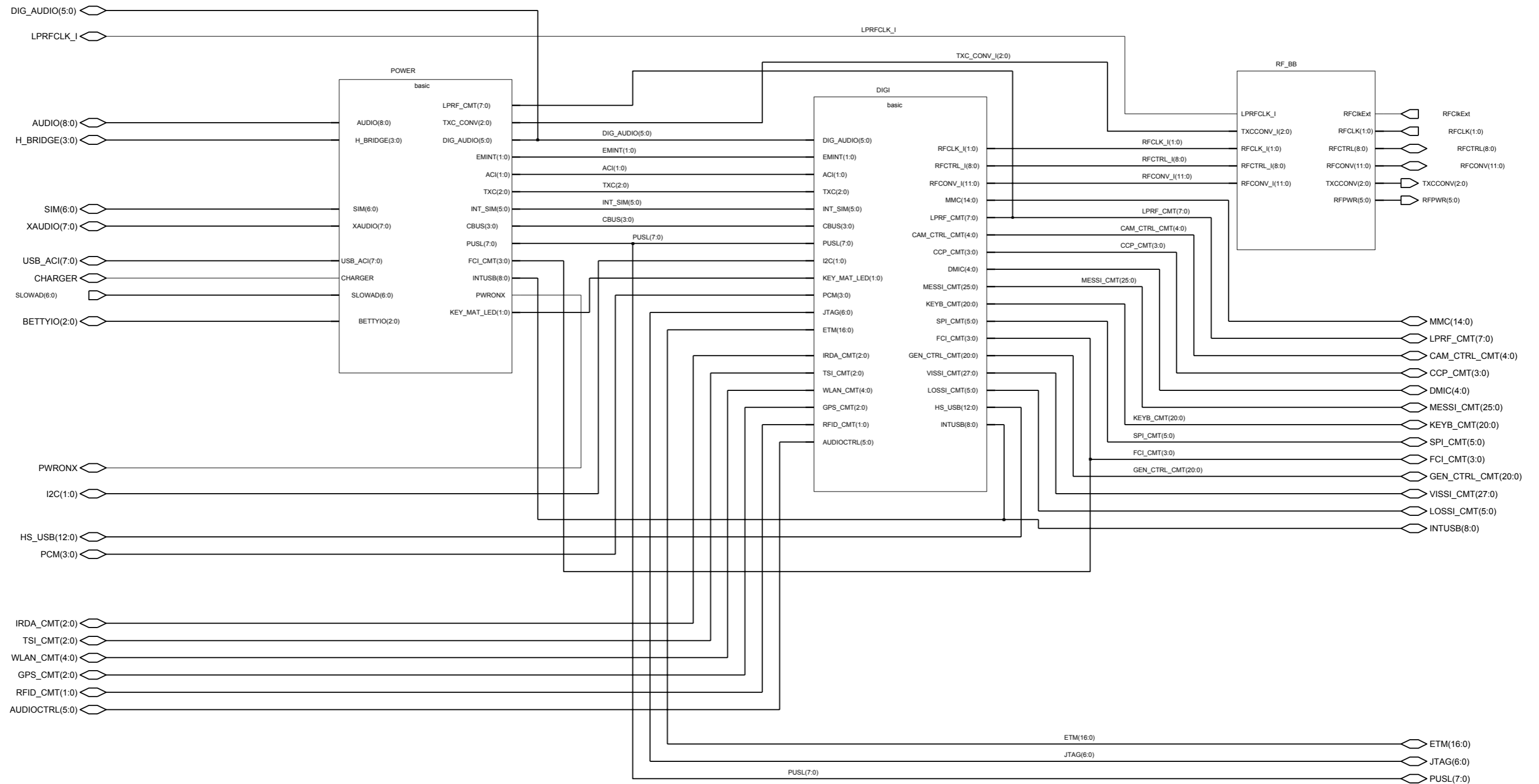

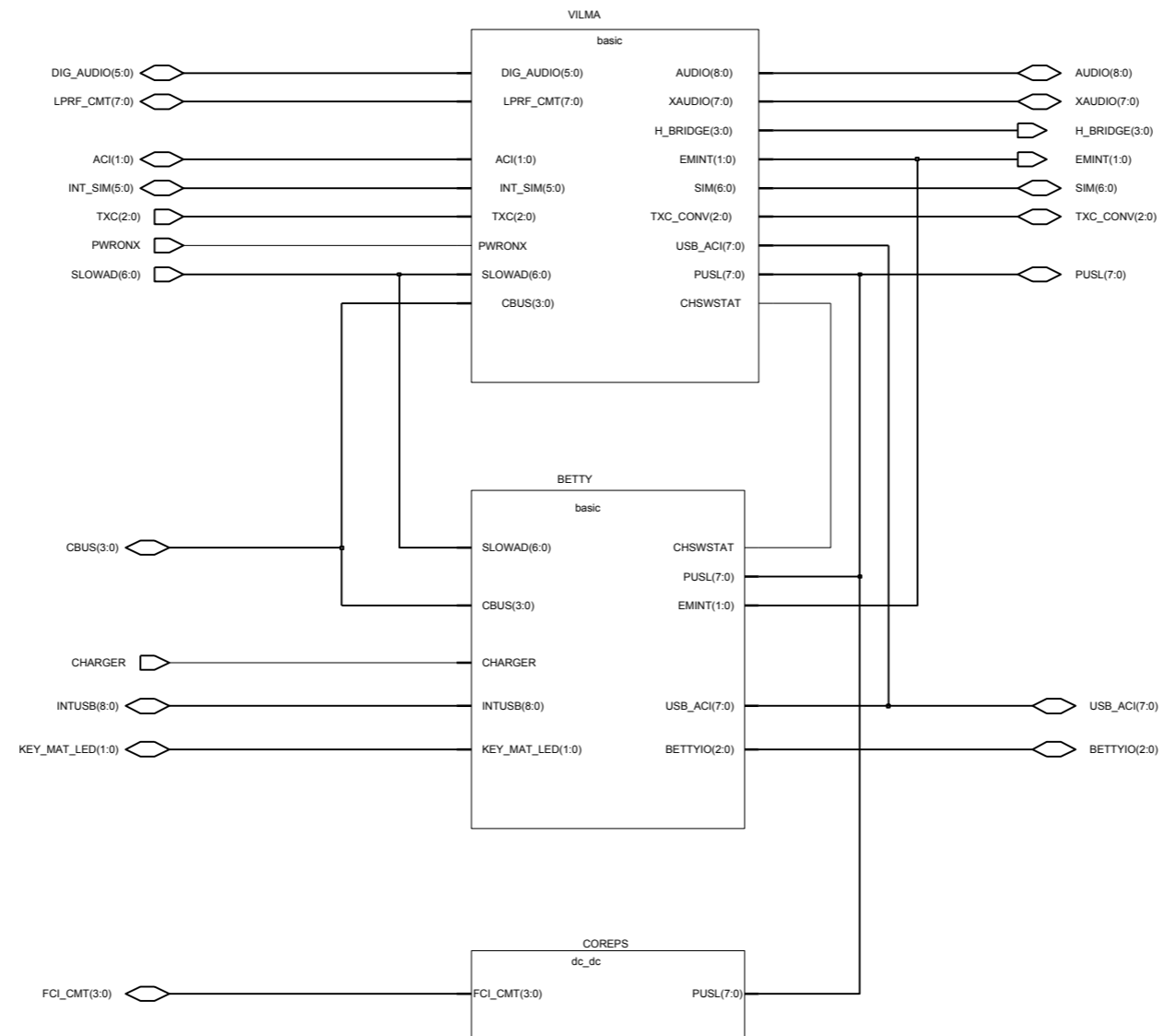

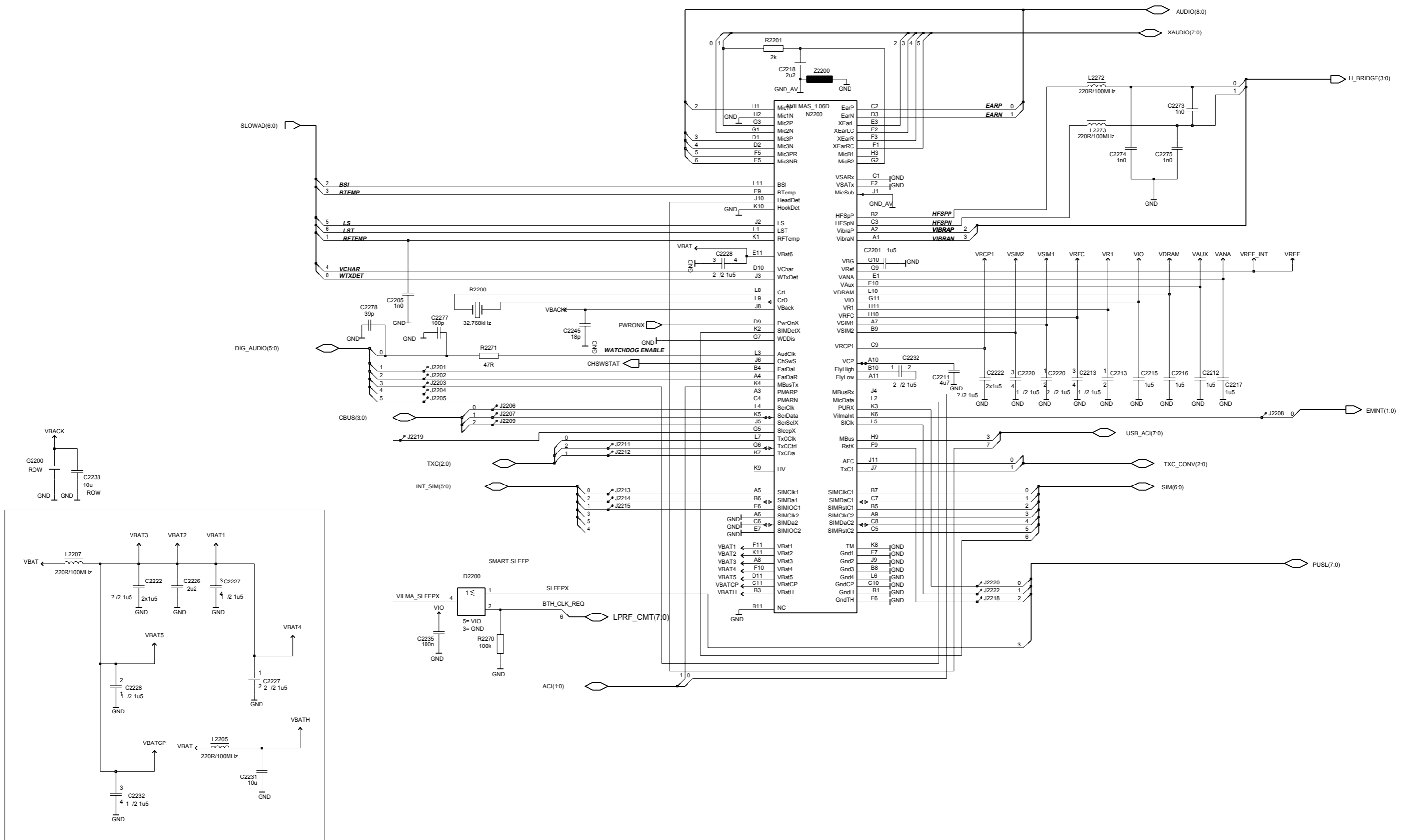

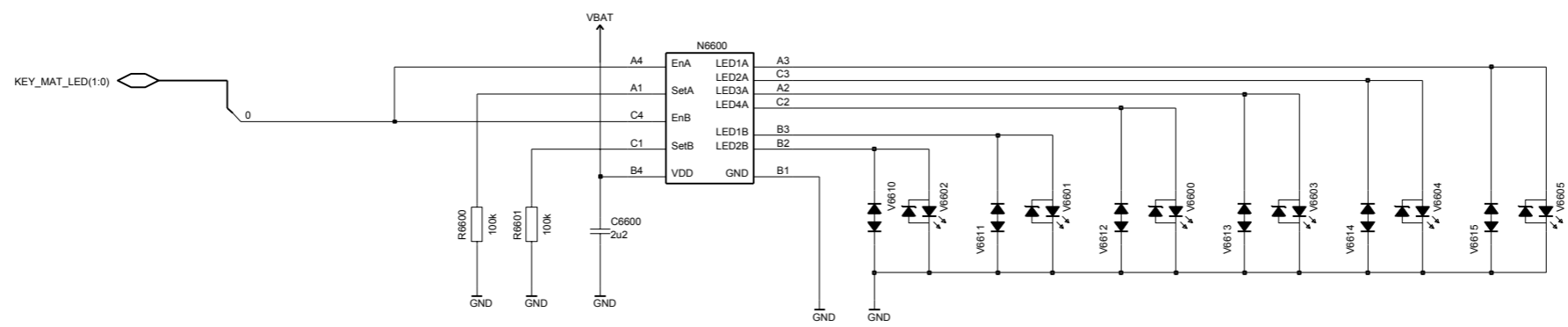
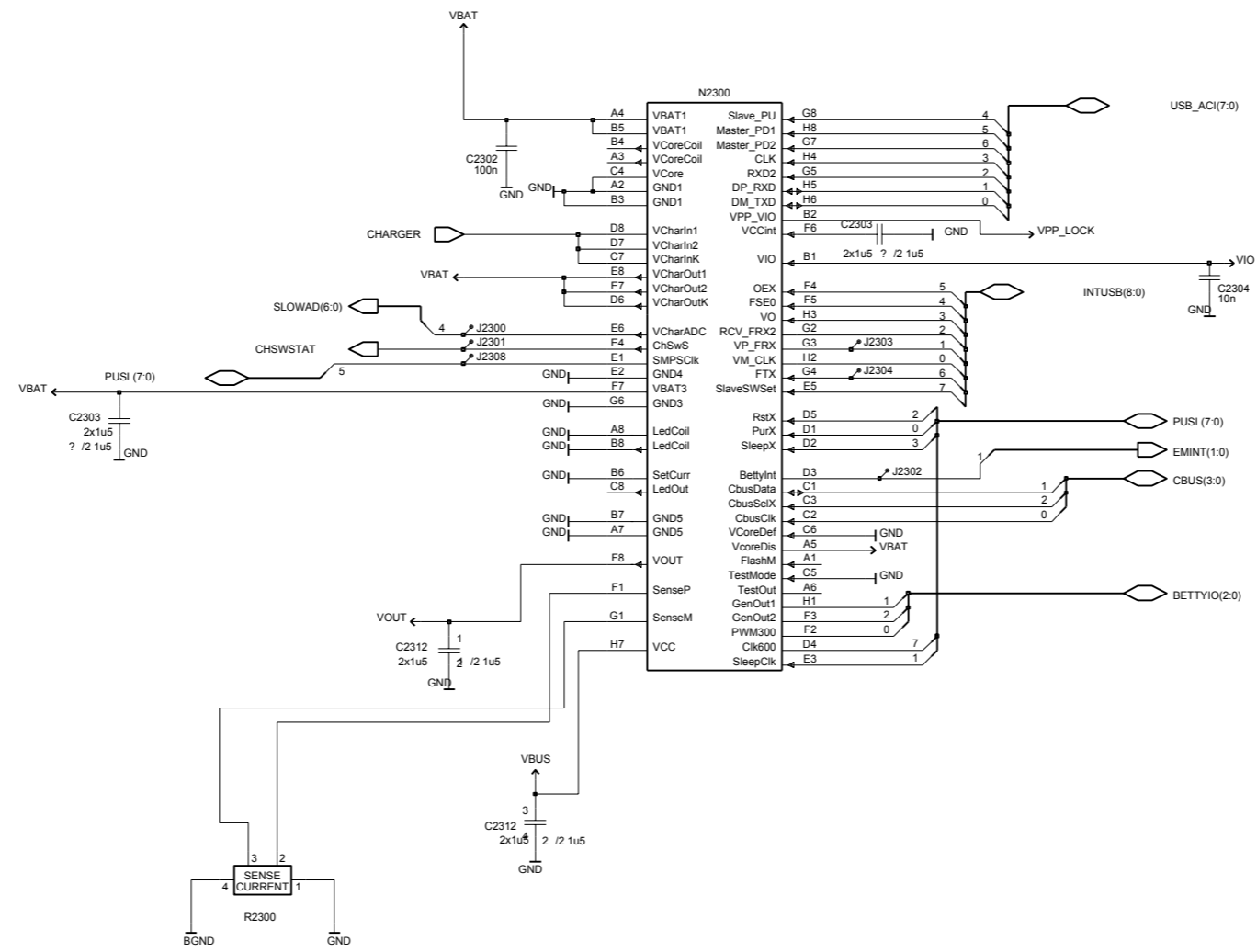

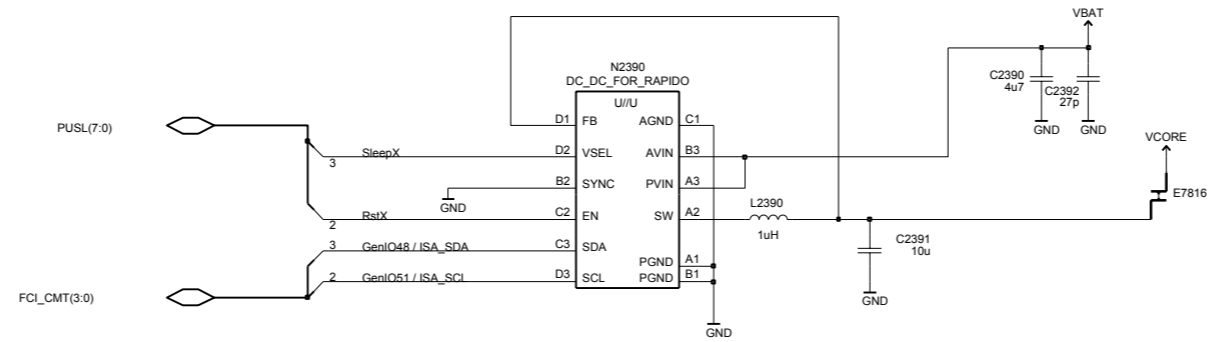

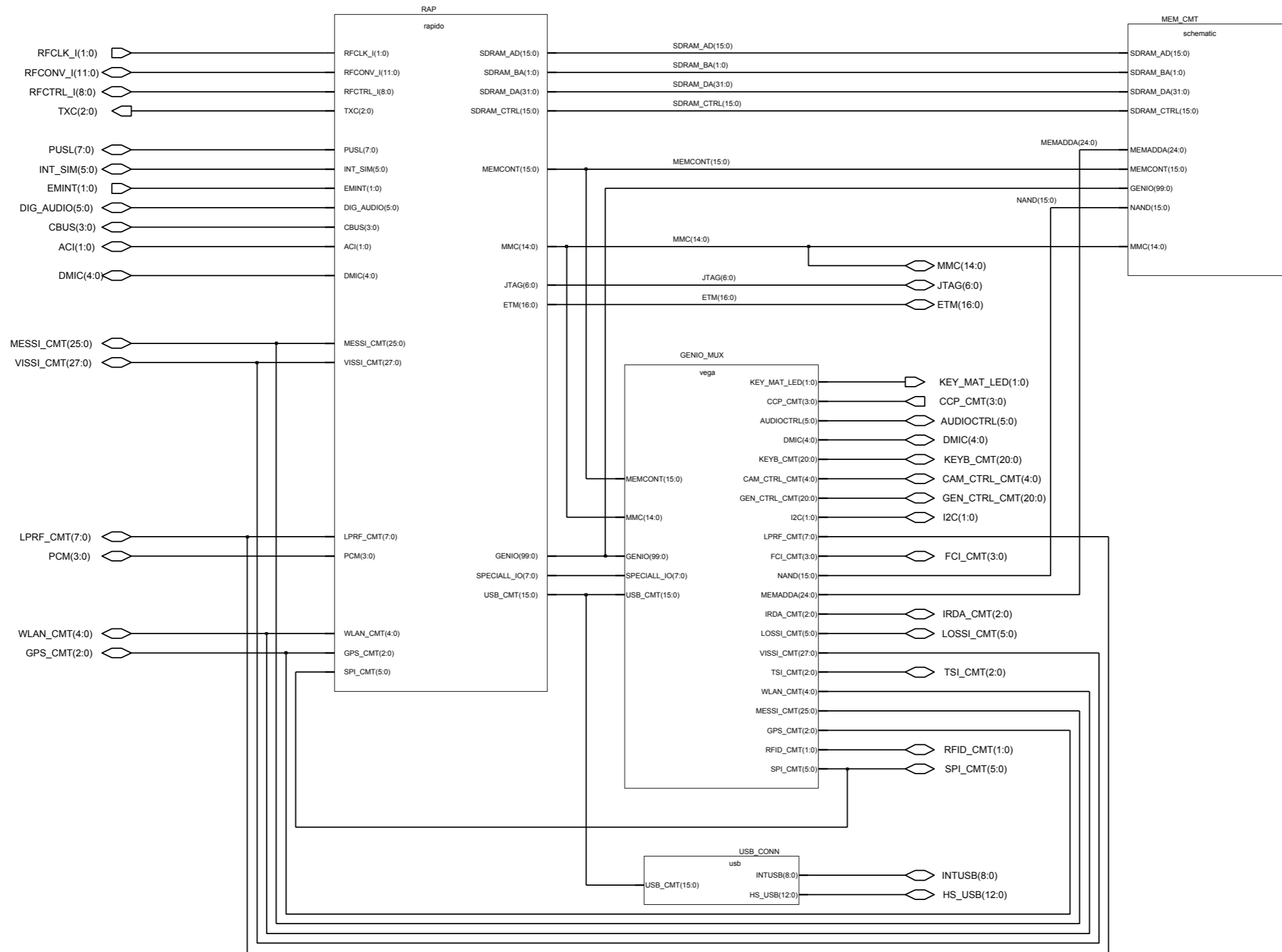



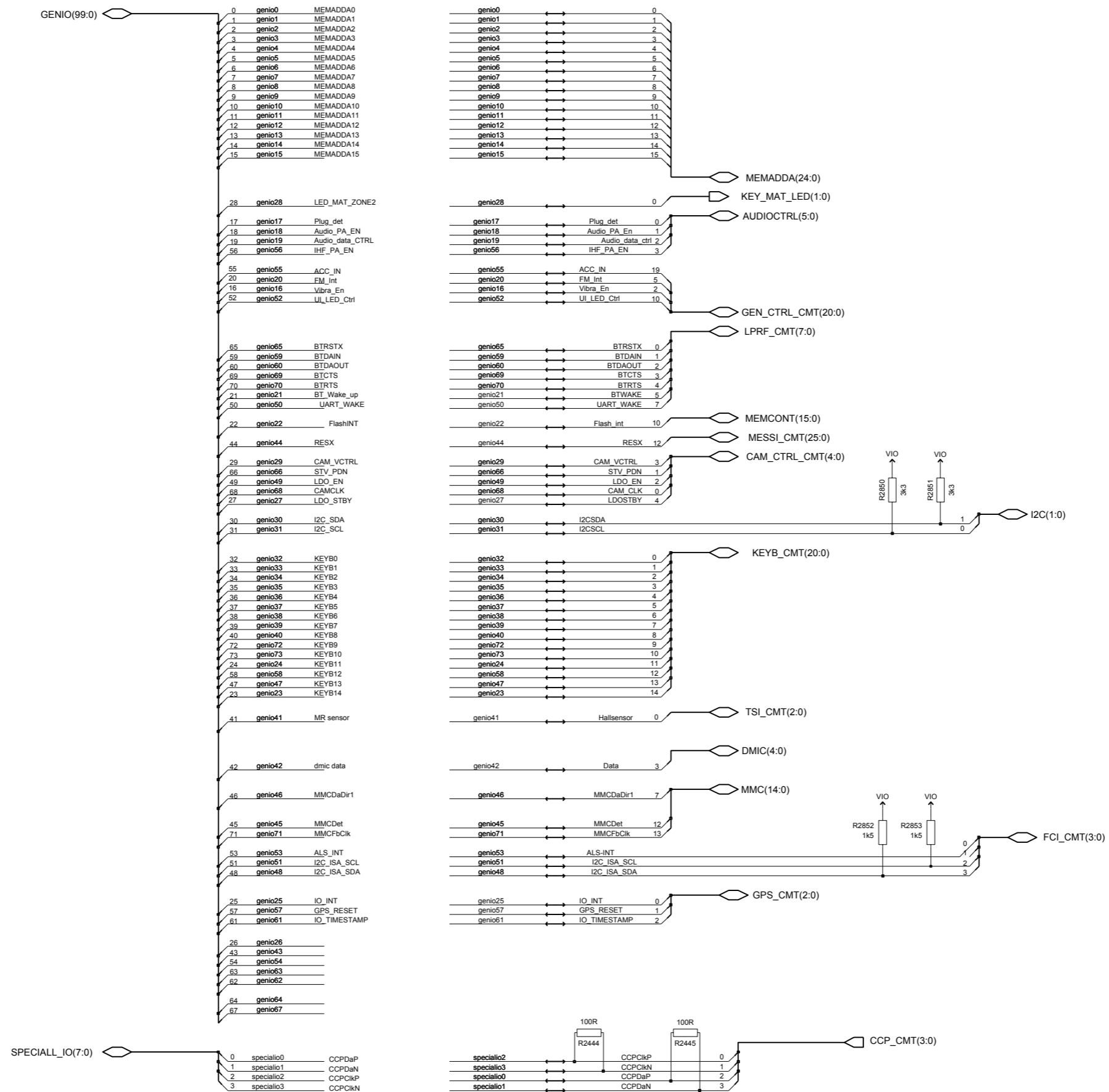

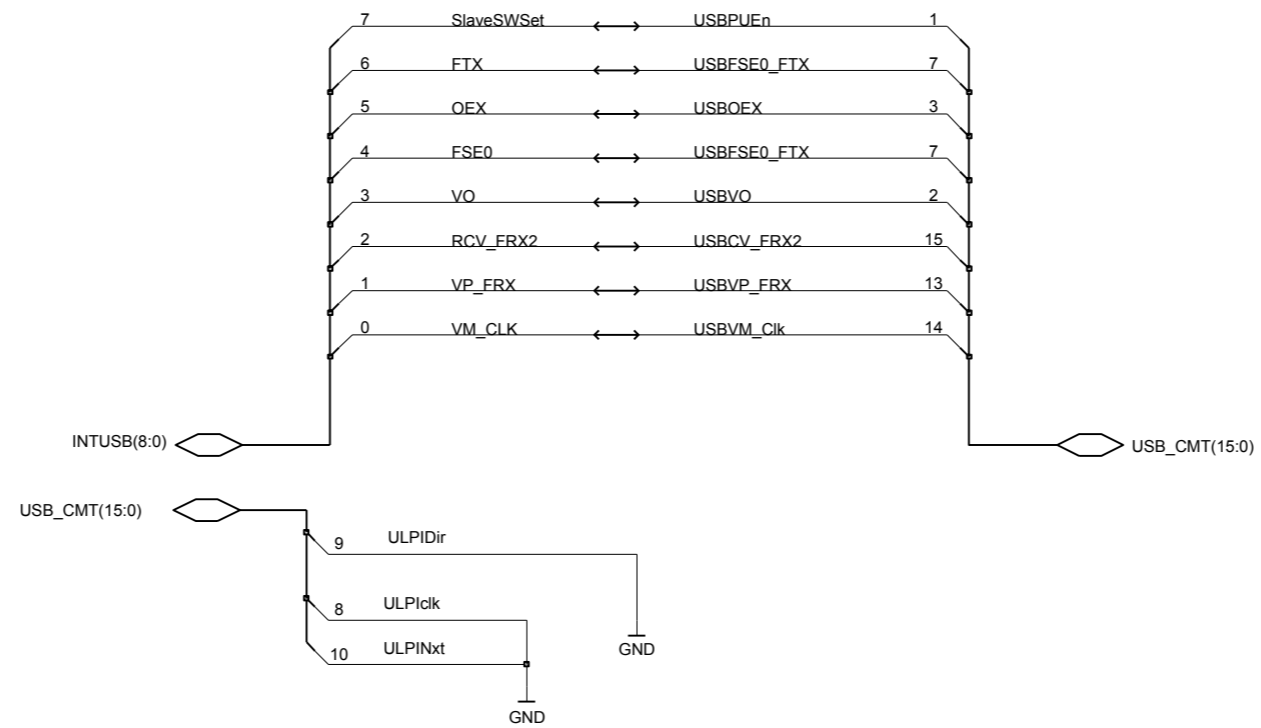

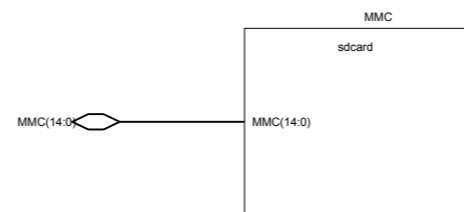
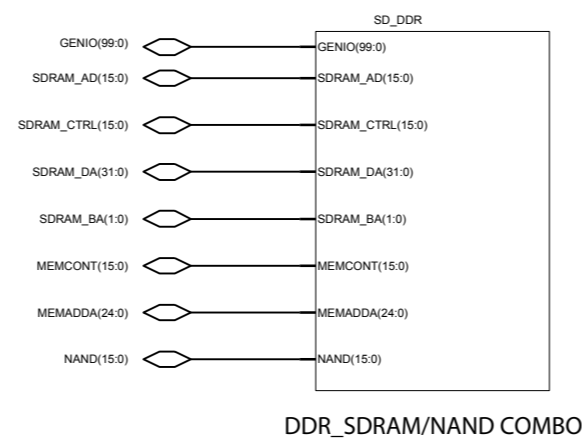

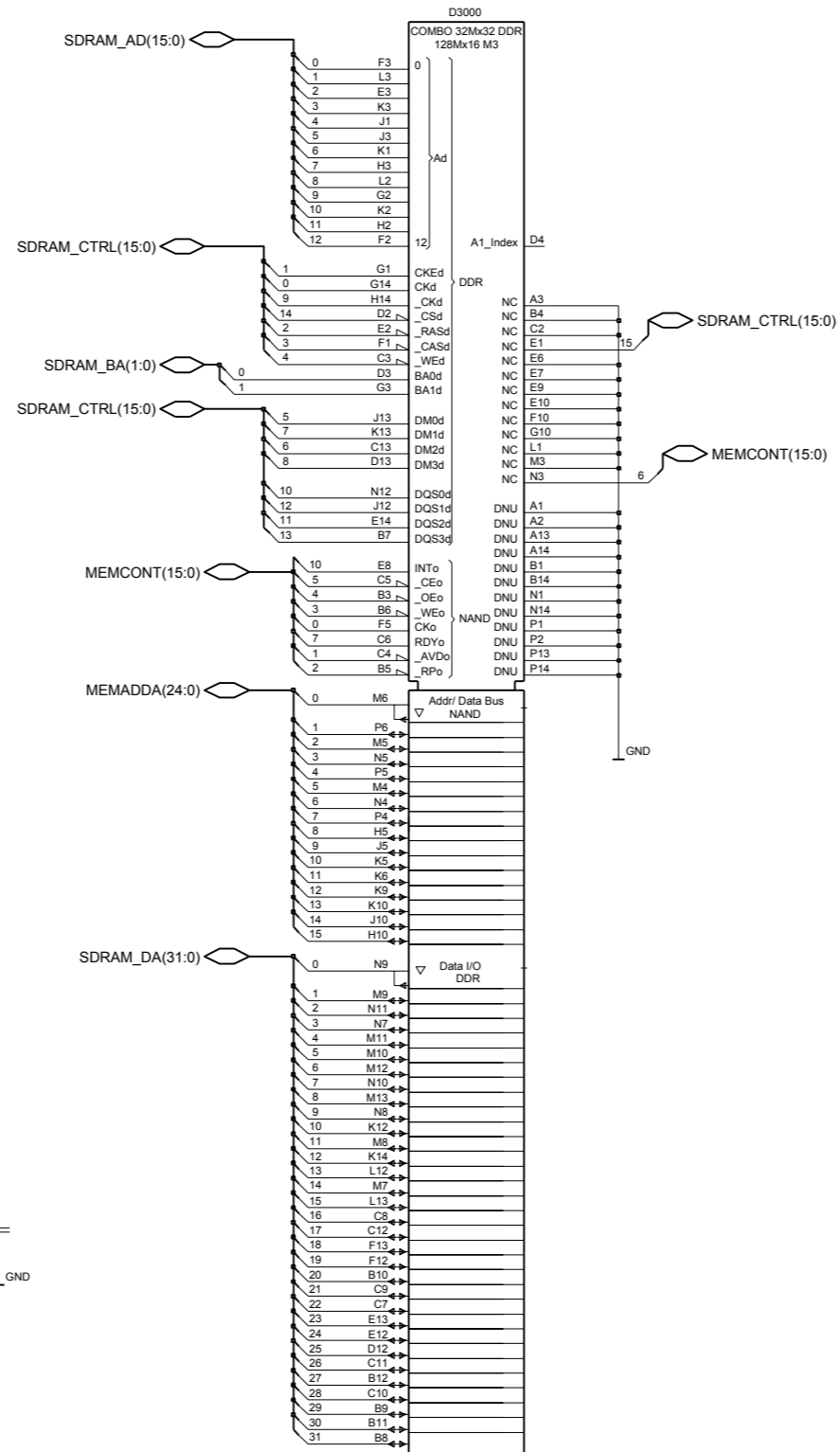
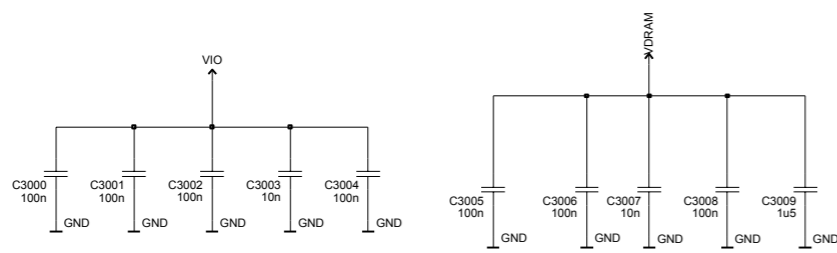

A11,D1,G12,H1,M2,P11= VDRAM  
 A7,A8,B13,C14,G13,H13,M14,N13,P7,P8= VIO  
 A5,E5= VIO  
 K7,N2= VIO  
 A6,A9,A12,D14,F14,J14,L14,N6,P9,P12= GND  
 A10,C1,H12,J2,M1,P10= GND  
 A4,B2,G5,K8,P3= GND

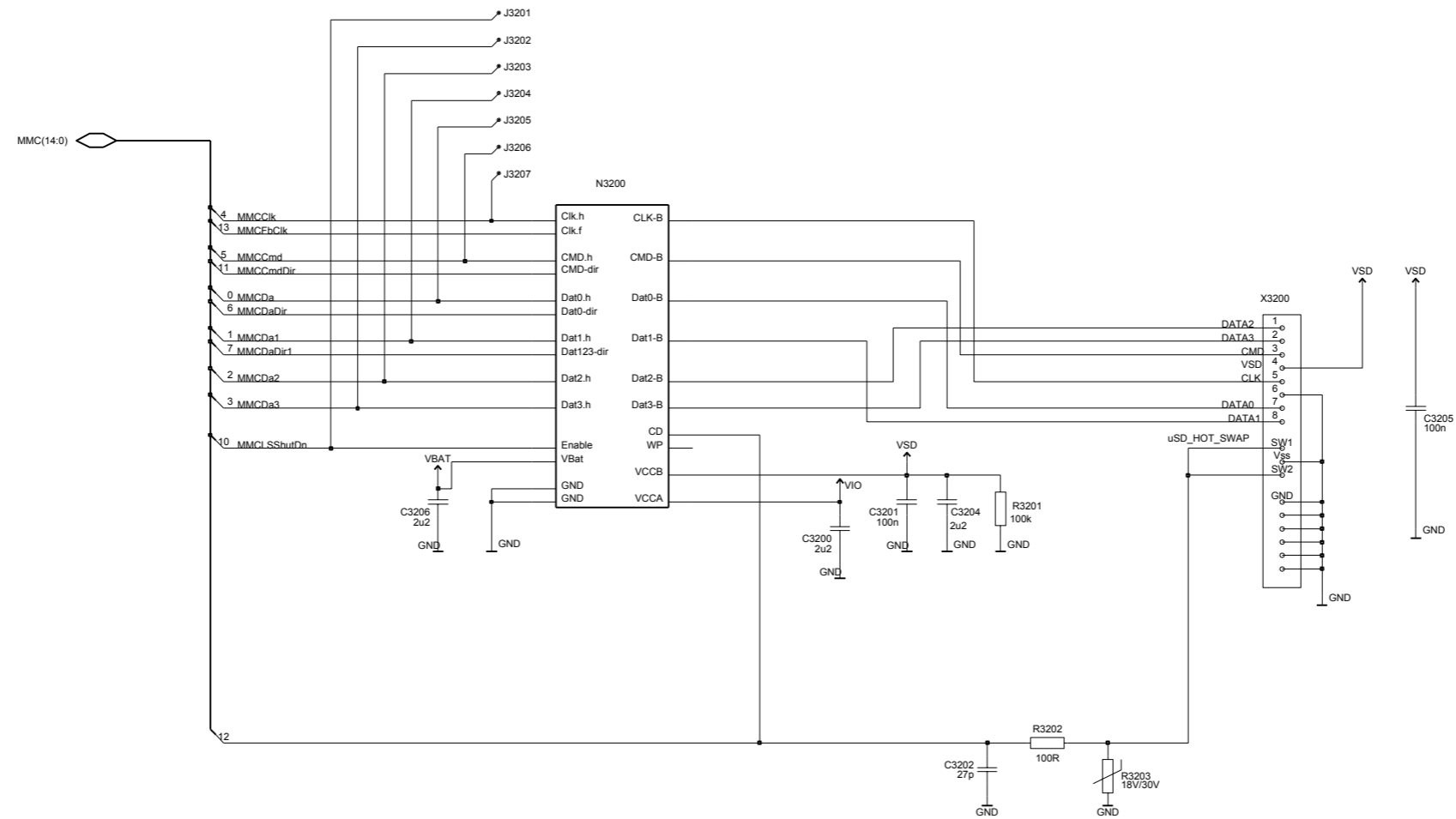

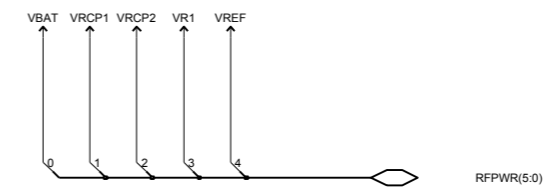
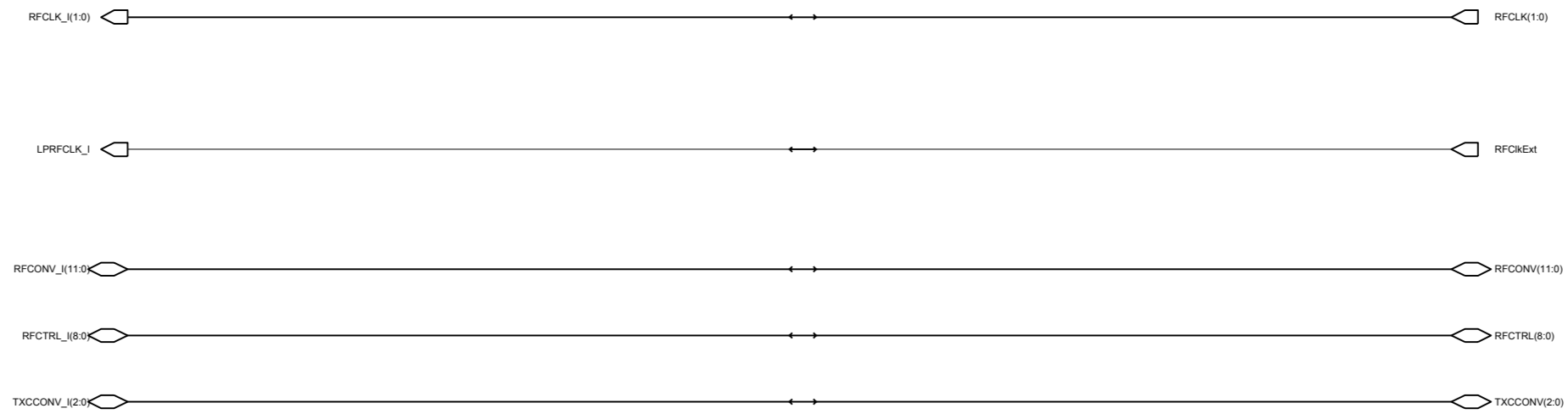

A	C2391	L5	C3200	G8	C7548	P4	L2390	L6	R	R7544	P3			
A2200	L8	C2392	L5	C3201	F8	C7549	N2	L2401	M8	R2000	H3	R7560	N2	
A2800	J8	C2400	07	C3202	H8	C7550	P3	L2402	M6	R2001	E9	R7565	H4	
A6000	J9	C2401	07	C3204	F8	C7553	P4	L2403	N6	R2002	D9	R7566	R4	
A6200	F9	C2402	M7	C3205	E11	C7566	H4	L2404	O6	R2003	D9	R7567	P2	
A6601	B9	C2403	M7	C3206	G8	C7567	H5	L2405	P6	R2006	M10	T		
A7501	N3	C2404	N6	C6000	H2	C7570	R4	L2406	07	R2011	E9	T7502	L4	
A7502	J3	C2405	N6	C6003	K9	C7580	I3	L2407	N7	R2015	C8	T7580	K2	
B	C2406	N6	C6004	K9	C7581	I2	L2447	L9	R2016	H2	V			
B2200	M9	C2407	N6	C6005	K9	C7582	I3	L2481	Q5	R2019	B7	V2431	P5	
C	C2408	N6	C6006	J10	C7583	I2	L2482	Q5	R2022	A7	V2450	P7		
C2000	D8	C2409	06	C6007	J9	C7590	K4	L2483	R3	R2060	F7	V6600	C7	
C2001	D8	C2410	06	C6008	J10	C7591	J4	L2484	R4	R2061	F7	V6601	G7	
C2002	D9	C2411	P6	C6009	K10	C7592	I3	L2485	Q6	R2062	F7	V6602	R7	
C2003	L10	C2431	P5	C6010	J10	C7594	M4	L2486	Q6	R2070	Q5	V6603	N7	
C2004	L10	C2438	L9	C6012	K10	C7595	B8	L6000	K9	R2071	D11	V6604	F7	
C2007	L9	C2439	K9	C6013	J10	C7596	D11	L6001	J9	R2102	E2	V6605	N7	
C2008	D7	C2440	M5	C6015	I9	C7597	D11	L6002	J9	R2105	D2	V6610	R7	
C2009	D7	C2700	F3	C6016	J9	C7598	D9	L6003	I9	R2110	D4	V6611	G7	
C2010	M11	C2701	F3	C6017	J9	C7599	D10	L6004	J9	R2111	D3	V6612	B7	
C2011	L9	C2702	E7	C6018	J9	D	L6005	J10	R2201	L11	V6613	M7		
C2013	E10	C2703	G3	C6020	J10	D2200	L8	L6010	H2	R2270	L8	V6614	E7	
C2014	M10	C2704	F3	C6022	K10	D2800	J7	L6200	E9	R2271	M9	V6615	07	
C2016	L10	C2800	J8	C6023	K10	D3000	J9	L6201	F9	R2300	P4	W		
C2071	Q2	C2801	H6	C6024	J9	D6601	B9	L6202	F8	R2402	K9	W6000	G2	
C2072	P3	C2802	K6	C6200	F10	E	L6203	B10	R2431	P5	X			
C2073	Q2	C2803	H8	C6201	F9	E2001	A8	L6605	E8	R2432	P5	X2060	E11	
C2074	P5	C2804	H6	C6202	F9	E2002	A8	L6610	F8	R2433	P5	X2070	D10	
C2101	D3	C2805	H7	C6203	F9	E2020	A7	L7500	K3	R2444	H7	X2071	D9	
C2102	D2	C2806	K7	C6204	J9	E2021	B7	L7501	K3	R2445	H7	X2072	L8	
C2103	D2	C2807	J5	C6205	G9	E2022	C7	L7503	J2	R2450	07	X2073	I8	
C2104	D2	C2808	J5	C6206	F9	E2023	B7	L7506	J4	R2451	07	X2074	G8	
C2105	D2	C2809	I5	C6207	F10	E2024	B6	L7510	N4	R2452	P7	X2075	G11	
C2106	C6	C2810	J8	C6209	G9	E2025	B6	L7521	K4	R2481	Q5	X2076	I11	
C2108	D6	C2811	I5	C6210	F9	E2060	P8	L7525	L3	R2482	Q5	X2077	L11	
C2110	D4	C2812	K6	C6211	E10	E2061	P9	L7540	O3	R2483	R3	X2078	P10	
C2111	D3	C2813	H6	C6212	G10	E2062	P11	L7550	P3	R2484	R4	X2079	P9	
C2201	M8	C2814	I5	C6502	Q7	E2101	D3	L7565	H5	R2485	Q6	X3200	F10	
C2205	M10	C2815	H6	C6503	P6	E2102	B3	L7566	R4	R2486	Q6	X6653	J1	
C2211	L8	C2816	J5	C6600	H4	E2103	B5	L7581	K3	R2801	J5	X6654	Q4	
C2212	L8	C2817	H10	C6610	F8	E2104	C5	L7582	K3	R2802	K7	X6655	F5	
C2213	L8	C2818	J5	C6622	B10	F	L7588	J4	R2850	Q6	X7501	O2		
C2215	L8	C2819	I8	C6623	B8	F2000	C8	L7590	K4	R2851	Q6	X7560	B9	
C2216	M9	C2820	I5	C6624	D10	G	L7591	P3	R2852	L6	X7590	R5		
C2217	L10	C2821	K7	C6625	B10	G2200	P10	L7592	J4	R2853	L6	X7591	R3	
C2218	L10	C2822	K7	C6626	C8	G6200	E10	N	R3201	F8	X7594	C10		
C2220	L8	C2823	I8	C6627	B8	G7501	I4	N2000	L9	R3202	H8	X7595	B10	
C2222	L8	C2824	K8	C6628	E10	L	N2001	M10	R3203	H8	X7600	N6		
C2226	L8	C2825	I8	C6629	E11	L2000	C8	N2101	D2	R6006	J10	Z		
C2227	L9	C2826	J8	C6631	F8	L2001	D9	N2200	L10	R6008	J9	Z2010	D8	
C2228	L9	C2827	H8	C6632	E8	L2002	D9	N2300	L7	R6201	B9	Z2401	N5	
C2231	L11	C2830	K6	C7500	I4	L2003	D7	N2390	L6	R6501	Q6	Z2402	O5	
C2232	L9	C2831	J5	C7507	J4	L2004	D7	N2401	L8	R6600	H3	Z2500	M5	
C2235	M8	C2832	K5	C7513	I3	L2005	D7	N2431	O5	R6601	H3	Z6000	I9	
C2238	P11	C2833	K5	C7518	J2	L2009	H3	N3200	G8	R7501	I4	Z6200	E9	
C2245	M11	C3000	H9	C7519	I4	L2011	D7	N6000	K9	R7502	I2	Z7501	K3	
C2273	L10	C3001	K9	C7520	I3	L2012	D7	N6200	F10	R7503	J2	Z7503	K3	
C2274	L10	C3002	K10	C7521	N2	L2013	B7	N6501	Q6	R7509	J4	Z7504	K3	
C2275	L10	C3003	K9	C7523	N4	L2015	B7	N6600	H4	R7522	K4	Z7521	M4	
C2277	M9	C3004	H10	C7524	L3	L2101	C2	N6601	E8	R7523	M2	Z7540	N4	
C2278	O6	C3005	H10	C7525	L2	L2102	C6	N6602	E10	R7524	M2	Z7541	N3	
C2302	L7	C3006	K10	C7540	N3	L2103	D6	N7505	J3	R7526	L2	Z7580	K2	
C2303	L6	C3007	H9	C7543	N2	L2205	L11	N7520	M3	R7527	M2	Z7582	J4	
C2304	L7	C3008	H9	C7544	P3	L2207	L8	N7540	O4	R7528	M4			
C2312	L6	C3009	K9	C7545	P2	L2272	L10	N7541	O2	R7541	P2			
C2390	L5	C3100	K8	C7547	O3	L2273	L10	N7590	K4	R7543	O3			

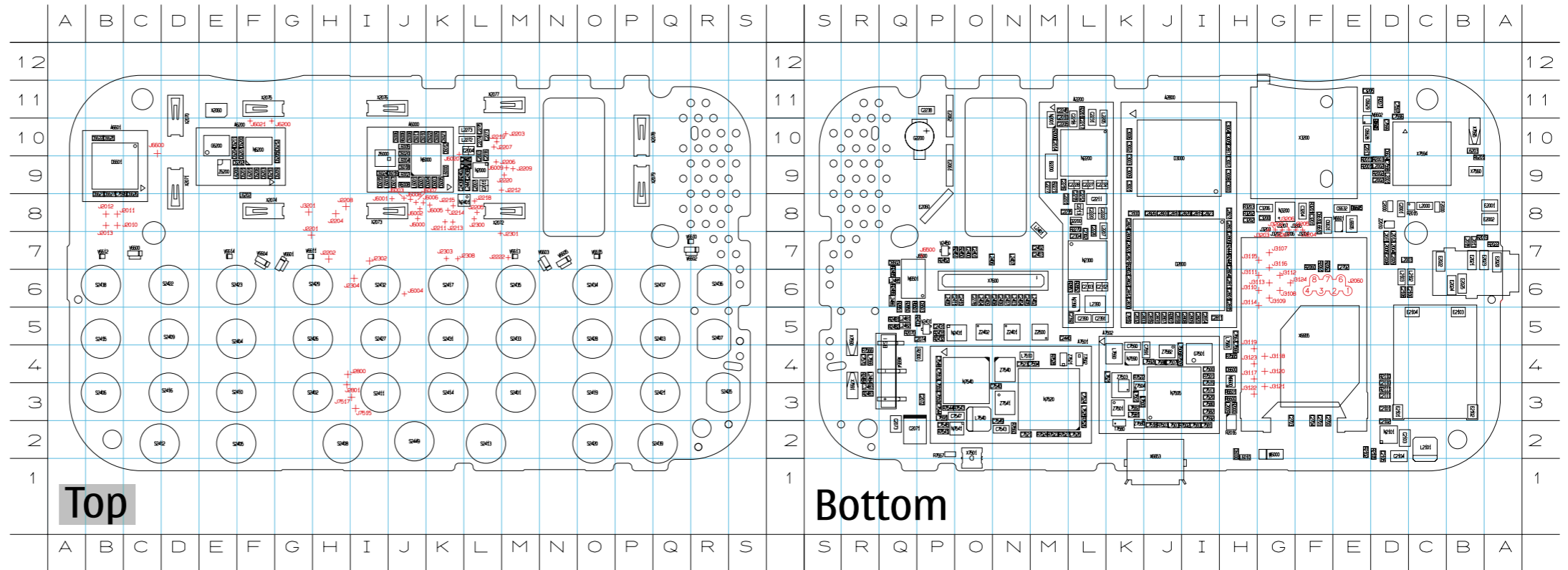

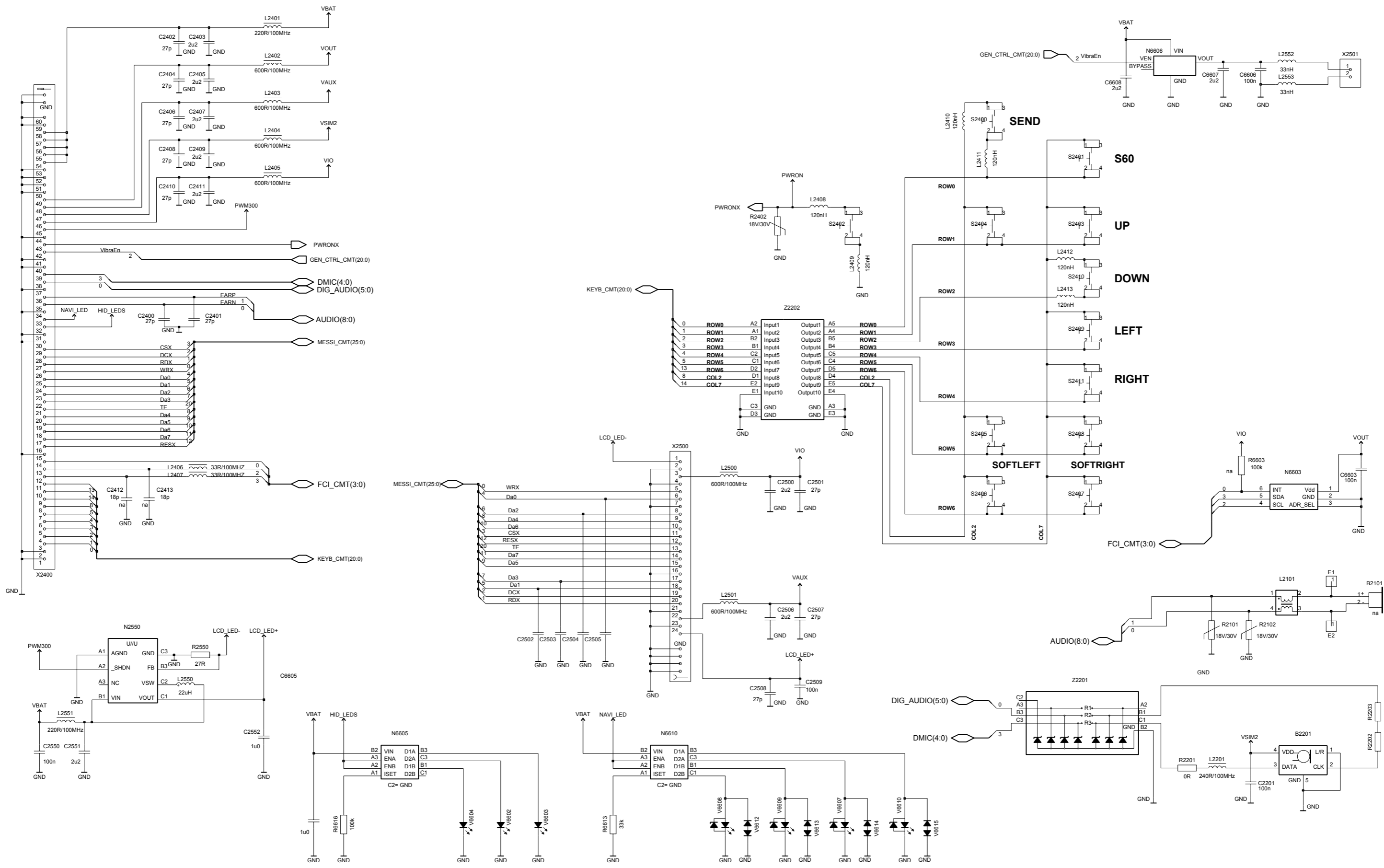

<b>A</b>	L2500	C17	
A2400	J14	L2501	C17
<b>B</b>	L2550	J15	
B2201	F18	L2551	J14
<b>C</b>	L2552	H1	
C2201	H17	L2553	G1
C2400	J12	<b>N</b>	
C2401	J12	N2550	J14
C2402	J13	N6603	E3
C2403	K13	N6605	I17
C2404	J12	N6606	H2
C2405	J12	N6610	H17
C2406	J13	<b>R</b>	
C2407	J13	R2101	I2
C2408	J13	R2102	I2
C2409	J13	R2201	G17
C2410	J14	R2202	G17
C2411	J14	R2203	G17
C2500	C17	R2402	D17
C2501	D17	R2550	K14
C2506	C17	R6613	H17
C2507	D17	R6616	H17
C2508	C17	<b>S</b>	
C2509	C17	S2400	H17
C2550	K14	S2401	J15
C2551	J14	S2402	C17
C2552	J14	S2403	E16
C6603	F3	S2404	J13
C6605	I17	S2405	J17
C6606	H1	S2406	H16
C6607	H1	S2407	C16
C6608	I2	S2408	E17
<b>E</b>	S2409	F17	
E1	H2	S2410	E18
E2	H1	S2411	D17
E3	A18	<b>V</b>	
E4	C18	V6602	J14
E5	A17	V6603	J16
E6	C17	V6604	J12
<b>L</b>	V6607	H17	
L2101	I2	V6608	C17
L2201	G17	V6609	H17
L2401	J14	V6610	B17
L2402	J12	V6612	C17
L2403	J13	V6613	H17
L2404	J13	V6614	G17
L2405	J14	V6615	B17
L2406	I12	<b>X</b>	
L2407	J12	X2400	B14
L2408	D17	X2500	B17
L2409	E17	X2501	H2
L2410	H17	<b>Z</b>	
L2411	H17	Z2201	G17
L2412	E17	Z2202	I17
L2413	E17		

