

Nokia Customer Care

Service Manual

RM-343; RM-345; RM-420 (Nokia E66)

Schematics

Part No: (Issue 1)

COMPANY CONFIDENTIAL



BLUETOOTH & FM RADIO DISCRETE

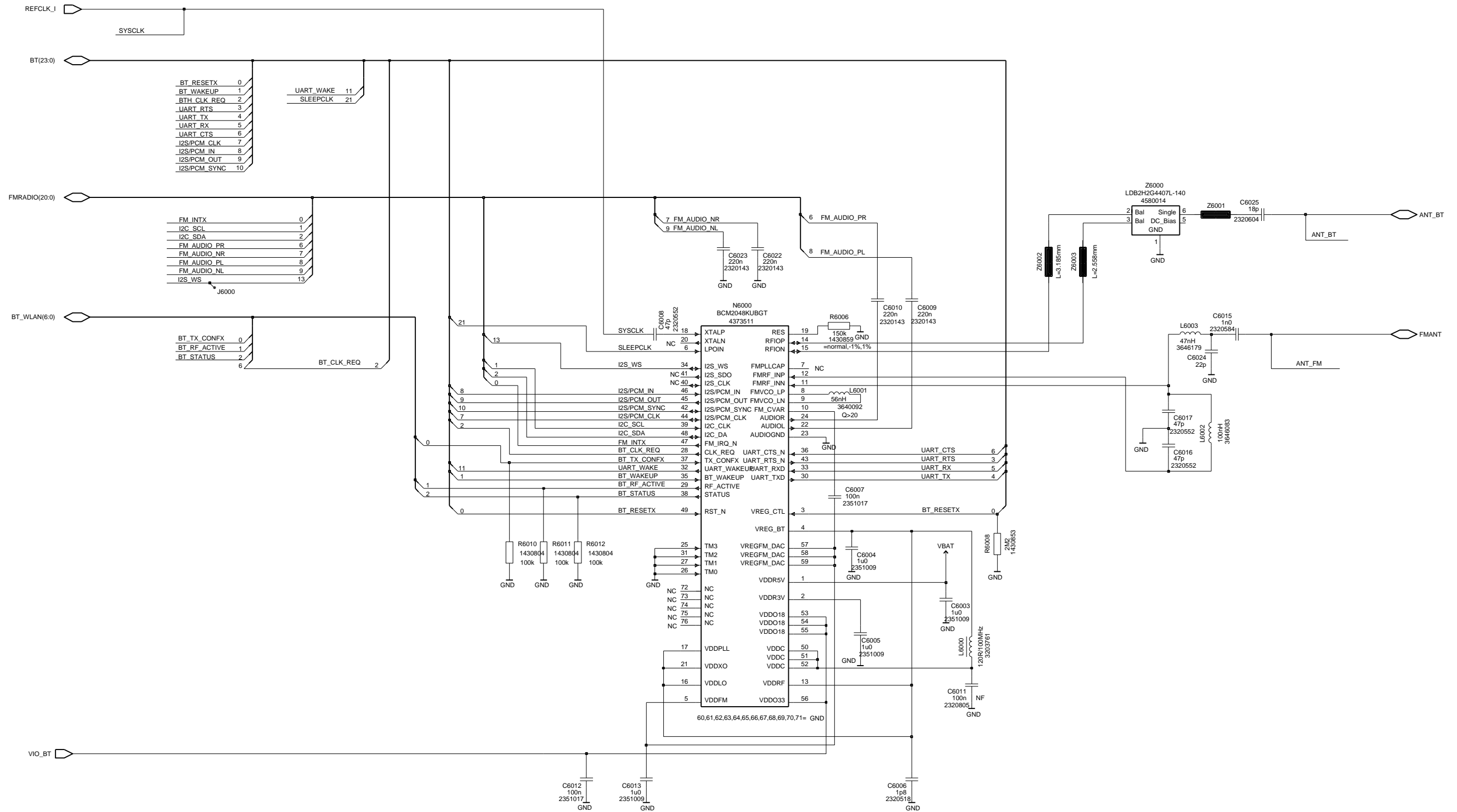

Notes.

- 1) 3k3 Pull-up Resistors are required on I2C_SCL & I2C_SDA
- 2) Additional test components for phone wing boards are given in BTHfmrds2.0_Test Schematic
- 3) E6033 will be used in future release for 1.8V operation.
- 4) A pull down is required on the CLK_REQ signal (see release note).

Copyright (C) Nokia Corporation. All rights reserved.
 THIS DRAWING IS PROTECTED BY COPYRIGHT AS AN UNPUBLISHED WORK.
 UNAUTHORIZED REPRODUCTION OF THIS DRAWING IS NOT PERMITTED.
 THIS DRAWING CONTAINS PROPRIETARY AND CONFIDENTIAL INFORMATION.
 This document is property of Nokia Corporation



Name: BTFM RDS 2.0D (3+2+3) WLAN
 Appr: dd-mmm-yy

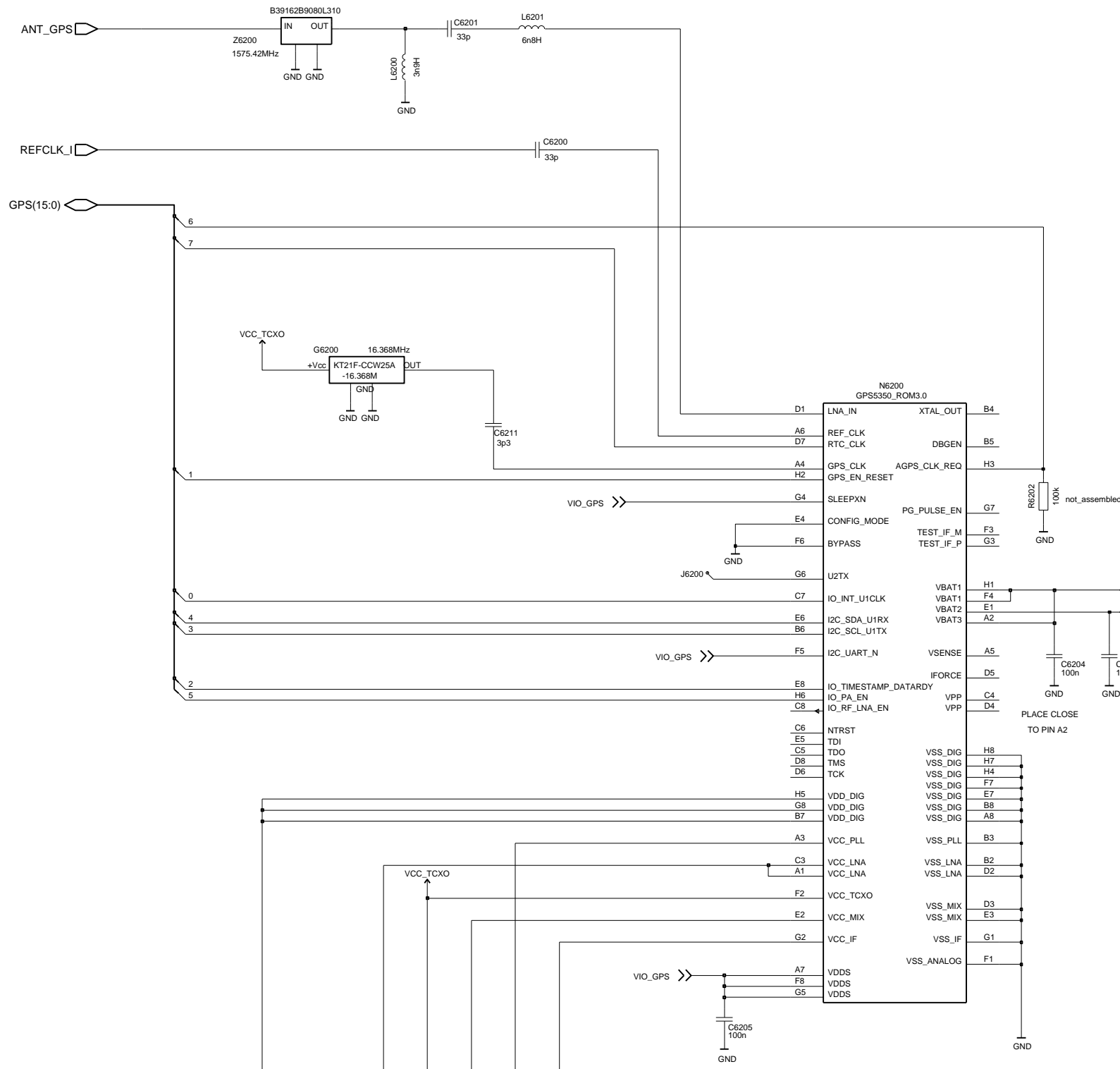

NOTES

- 1) TRACK INDUCTANCE FROM VDD_DIG, N6200-H5 TO C6212 MUST BE 1nH MAX.
- 2) TRACK INDUCTANCE FROM VDD_XXX, N6200 TO DECOUPLING CAPS MUST BE 1nH MAX.

MODE	CONNECT N6200 (PIN)	TO
CUSTOMERS NOT USING PA BLANKING	IO_PA_EN	GND (PREVENTS FLOATING INPUT)
MODE		



REF RANGE = 6200-6299

Copyright (C) Nokia Corporation. All rights reserved.
 THIS DRAWING IS PROTECTED BY COPYRIGHT AS AN UNPUBLISHED WORK.
 UNAUTHORIZED REPRODUCTION OF THIS DRAWING IS NOT PERMITTED.
 THIS DRAWING CONTAINS PROPRIETARY AND CONFIDENTIAL INFORMATION.
 This document is property of Nokia Corporation



Name SOLO COST 4.0 REFERENCE Appr dd-mmm-yy

- I2S_CMT_AUDIO(5:0)
- PUSL(7:0)
- FCL_CMT(3:0)
- AUDIOCTRL(5:0)
- I2C(1:0)
- XAUDIO(7:0)

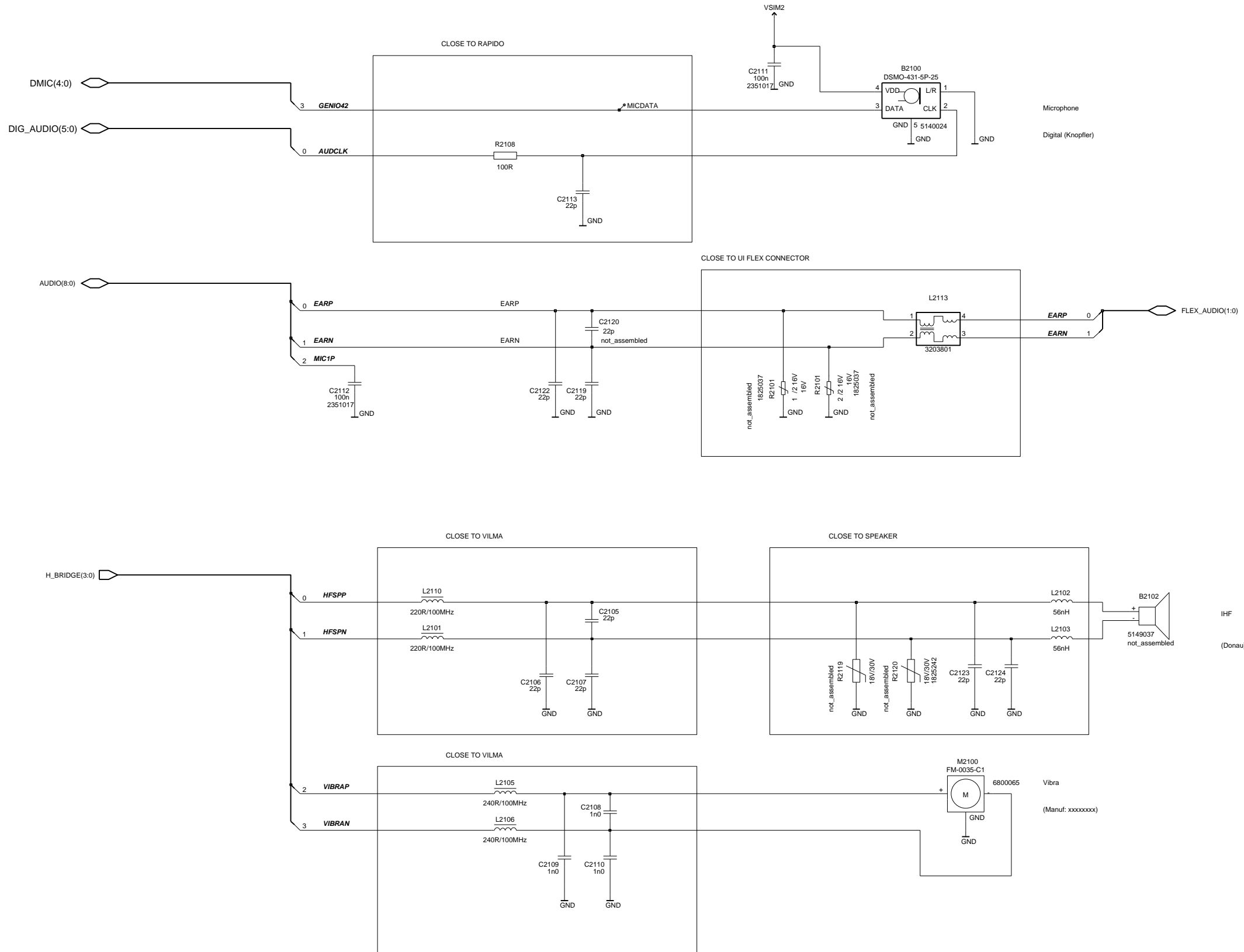

Copyright (C) Nokia Corporation. All rights reserved.
 THIS DRAWING IS PROTECTED BY COPYRIGHT AS AN UNPUBLISHED WORK.
 UNAUTHORIZED REPRODUCTION OF THIS DRAWING IS NOT PERMITTED.
 THIS DRAWING CONTAINS PROPRIETARY AND CONFIDENTIAL INFORMATION.
 This document is property of Nokia Corporation



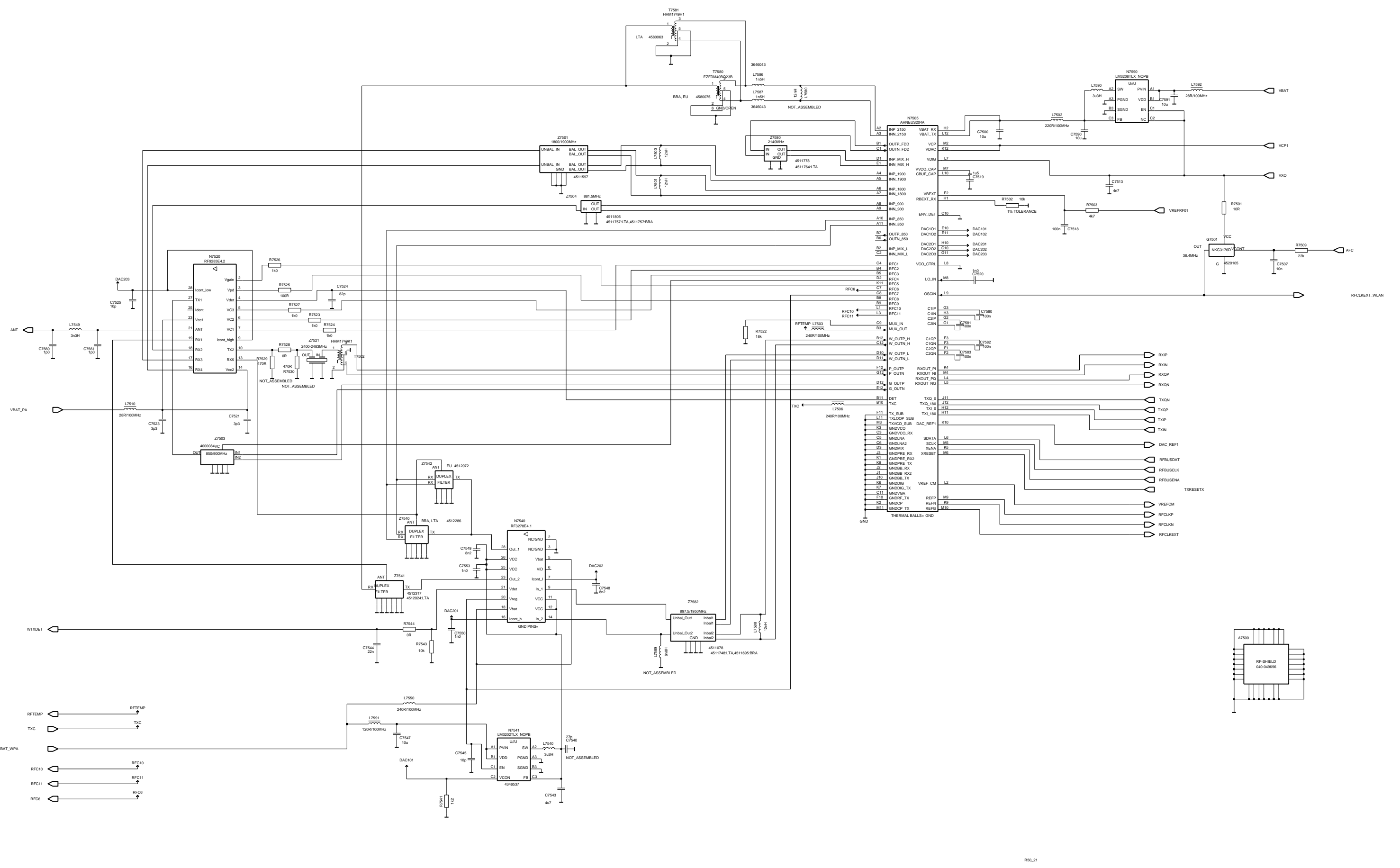

R50_21

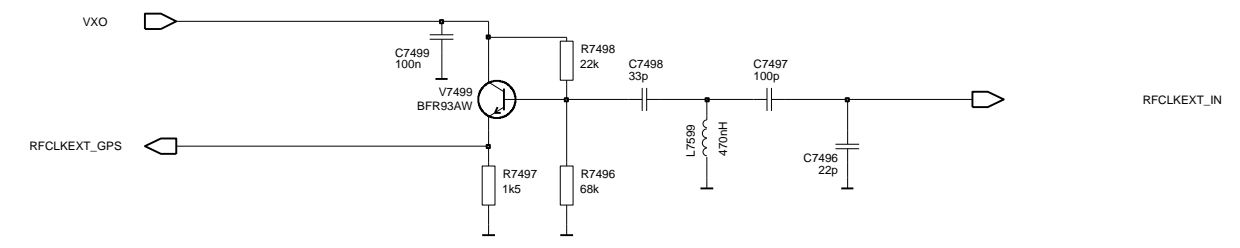
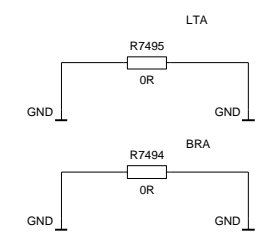
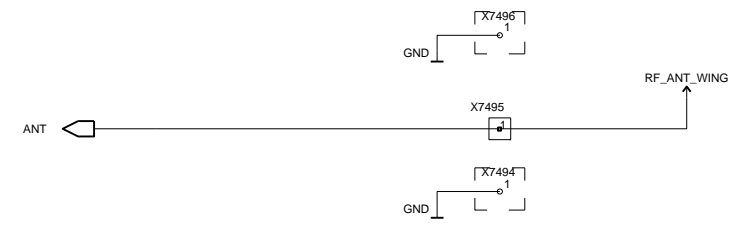

▷ RFCLKEXT_BT

◁ VBAT

◁ RFC10

◁ RFC11

Copyright (C) Nokia Corporation. All rights reserved.
 THIS DRAWING IS PROTECTED BY COPYRIGHT AS AN UNPUBLISHED WORK.
 UNAUTHORIZED REPRODUCTION OF THIS DRAWING IS NOT PERMITTED.
 THIS DRAWING CONTAINS PROPRIETARY AND CONFIDENTIAL INFORMATION.
 This document is property of Nokia Corporation



Name	RF Product Specific Sheet	Appr	dd-mmm-yy
------	---------------------------	------	-----------

CELLULAR schematic

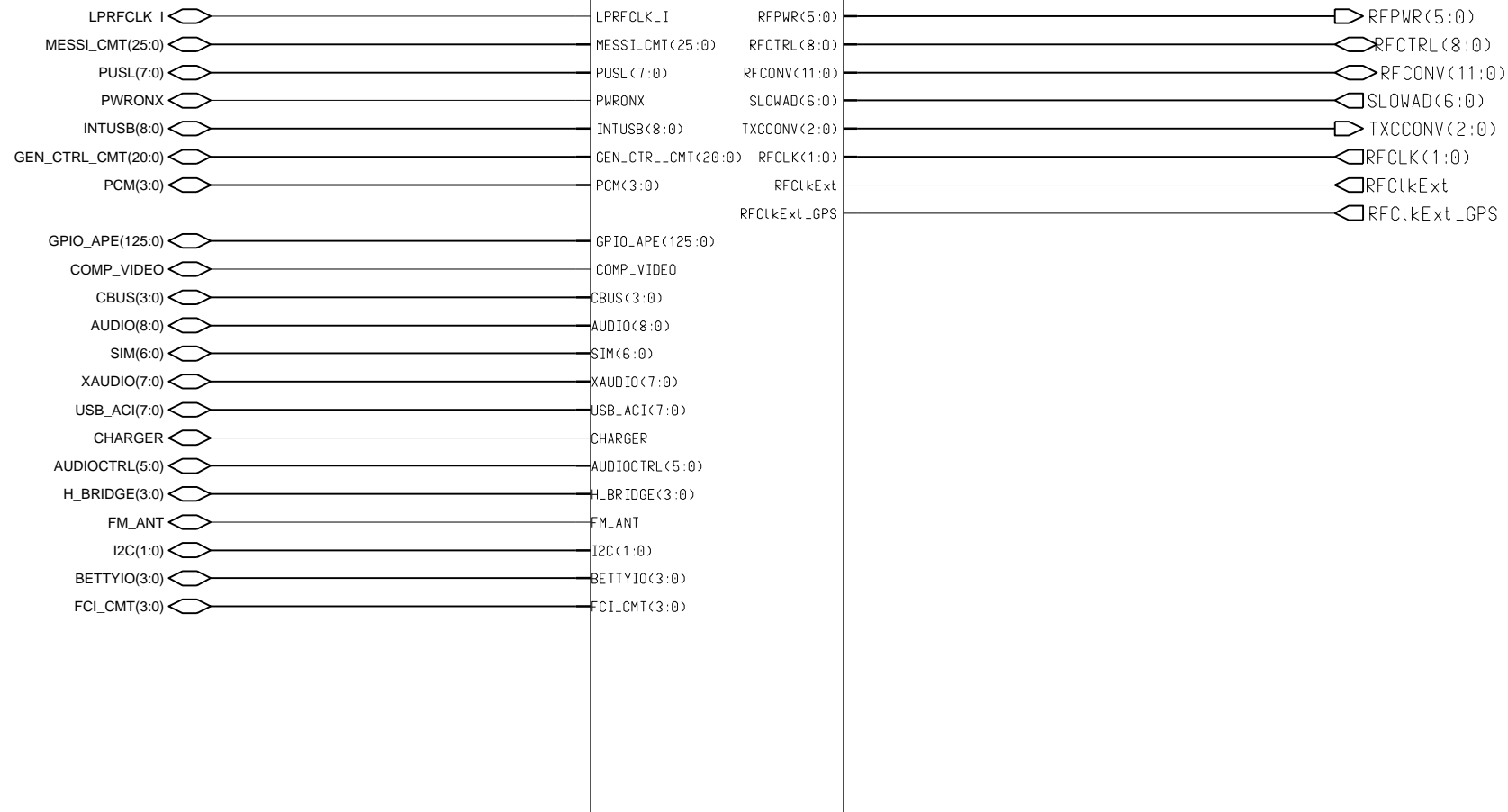

Copyright (C) Nokia Corporation. All rights reserved.
 THIS DRAWING IS PROTECTED BY COPYRIGHT AS AN UNPUBLISHED WORK.
 UNAUTHORIZED REPRODUCTION OF THIS DRAWING IS NOT PERMITTED.
 THIS DRAWING CONTAINS PROPRIETARY AND CONFIDENTIAL INFORMATION.
 This document is property of Nokia Corporation



Name BB Top Level Appr dd-mmm-yy

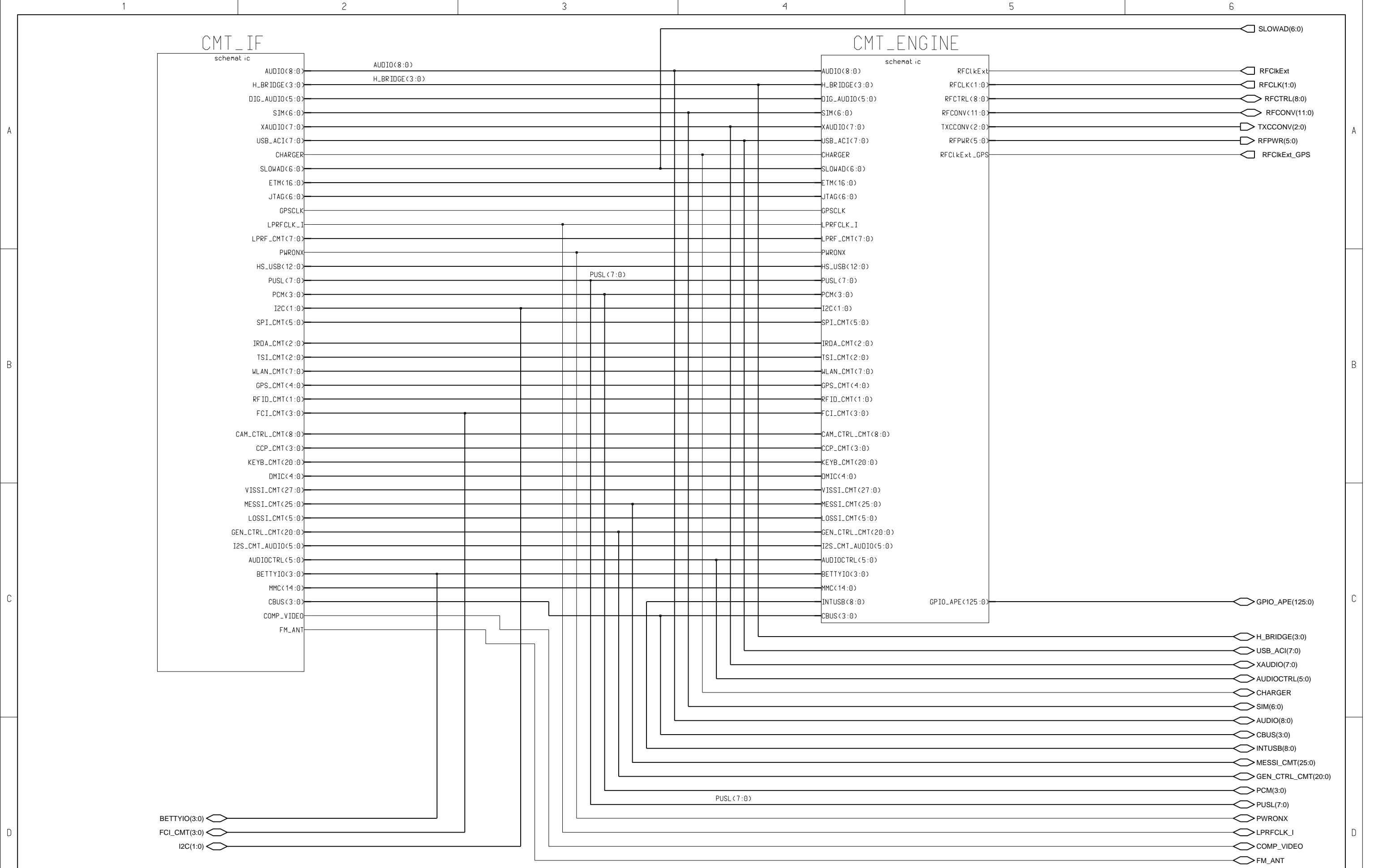

Copyright (C) Nokia Corporation. All rights reserved.
 THIS DRAWING IS PROTECTED BY COPYRIGHT AS AN UNPUBLISHED WORK.
 UNAUTHORIZED REPRODUCTION OF THIS DRAWING IS NOT PERMITTED.
 THIS DRAWING CONTAINS PROPRIETARY AND CONFIDENTIAL INFORMATION.
 This document is property of Nokia Corporation



Name Cellular Top Level Appr dd-mmm-yy

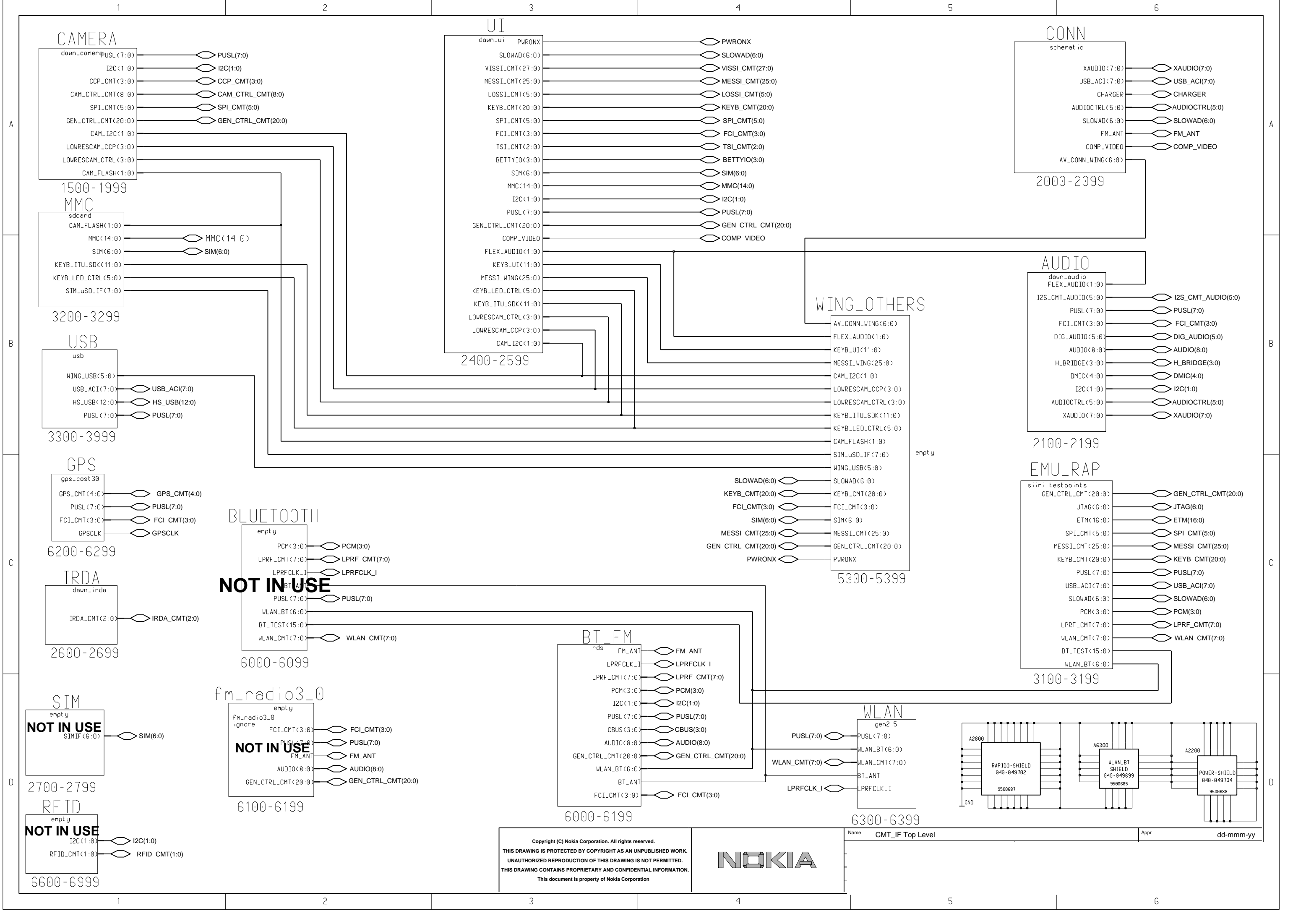

NOT IN USE

Copyright (C) Nokia Corporation. All rights reserved.
 THIS DRAWING IS PROTECTED BY COPYRIGHT AS AN UNPUBLISHED WORK.
 UNAUTHORIZED REPRODUCTION OF THIS DRAWING IS NOT PERMITTED.
 THIS DRAWING CONTAINS PROPRIETARY AND CONFIDENTIAL INFORMATION.
 This document is property of Nokia Corporation



Name	CMT_IF Top Level	Appr	dd-mmm-yy
------	------------------	------	-----------

3300-3999

- HS_USB(12:0)
- PUSL(7:0)
- WING_USB(5:0)

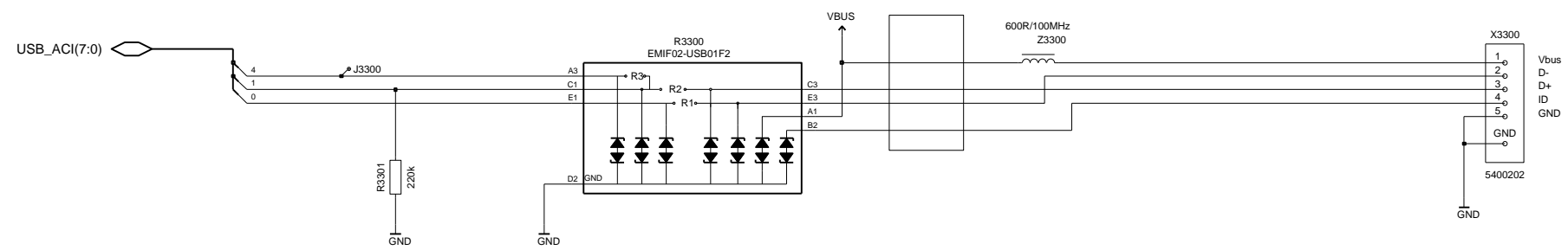

Copyright (C) Nokia Corporation. All rights reserved.
THIS DRAWING IS PROTECTED BY COPYRIGHT AS AN UNPUBLISHED WORK.
UNAUTHORIZED REPRODUCTION OF THIS DRAWING IS NOT PERMITTED.
THIS DRAWING CONTAINS PROPRIETARY AND CONFIDENTIAL INFORMATION.
This document is property of Nokia Corporation



Name Standard USB

Appr dd-mmm-yy

2600-2699

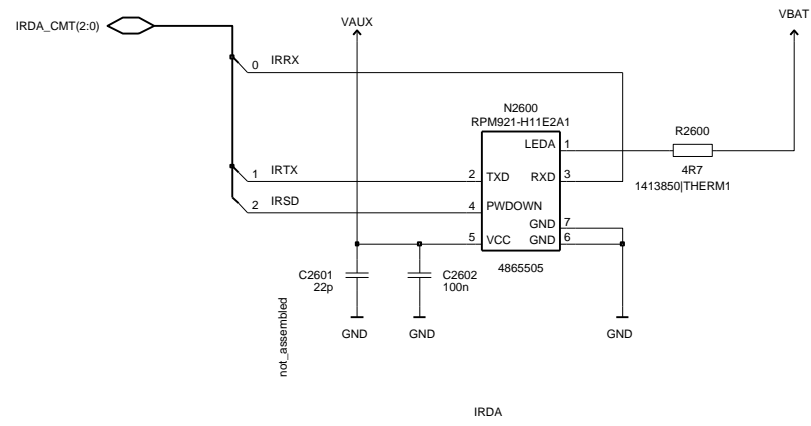

Copyright (C) Nokia Corporation. All rights reserved.
THIS DRAWING IS PROTECTED BY COPYRIGHT AS AN UNPUBLISHED WORK.
UNAUTHORIZED REPRODUCTION OF THIS DRAWING IS NOT PERMITTED.
THIS DRAWING CONTAINS PROPRIETARY AND CONFIDENTIAL INFORMATION.
This document is property of Nokia Corporation



Name IRDA

Appr dd-mmm-yy

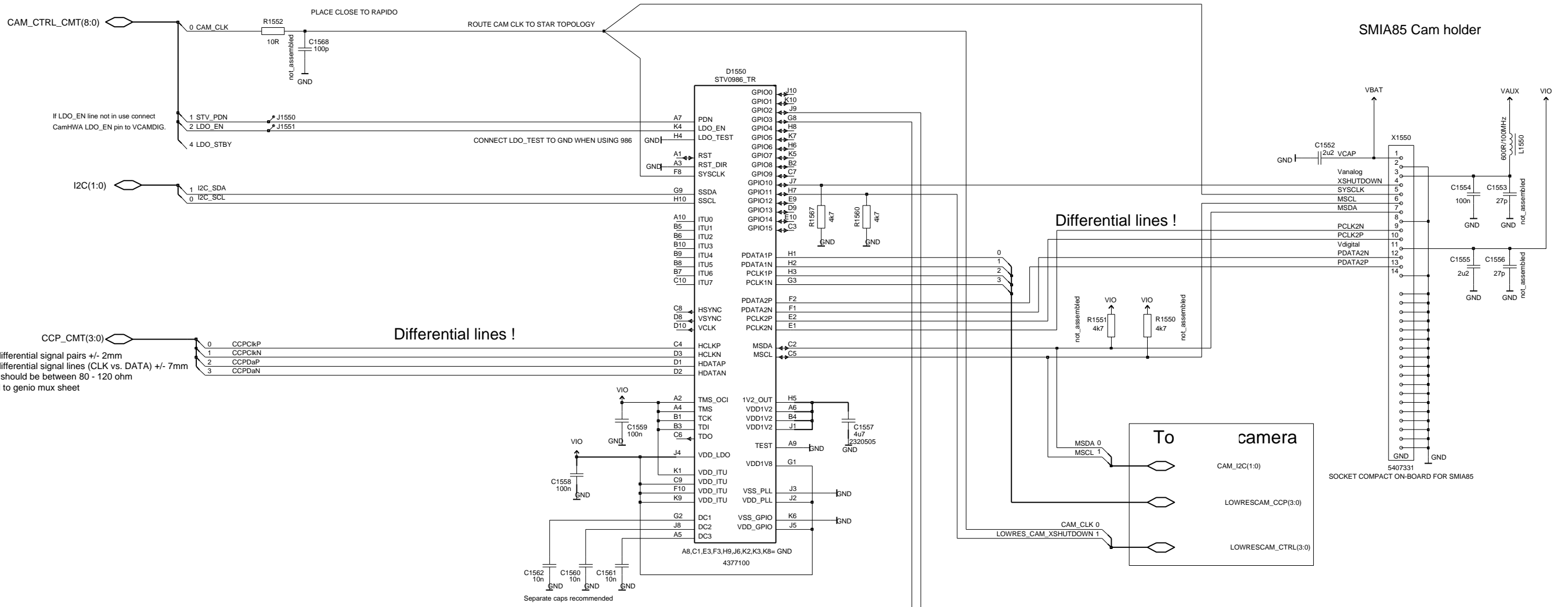

Lenght difference between differential signal pairs +/- 2mm
 Lenght difference between differential signal lines (CLK vs. DATA) +/- 7mm
 Differential lines impedance should be between 80 - 120 ohm
 Termination resistors placed to genio mux sheet

Differential lines !

Differential lines !

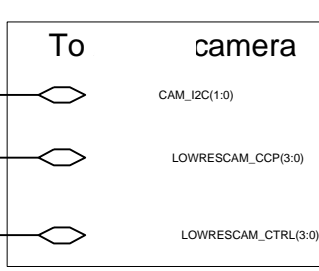

Flash Driver

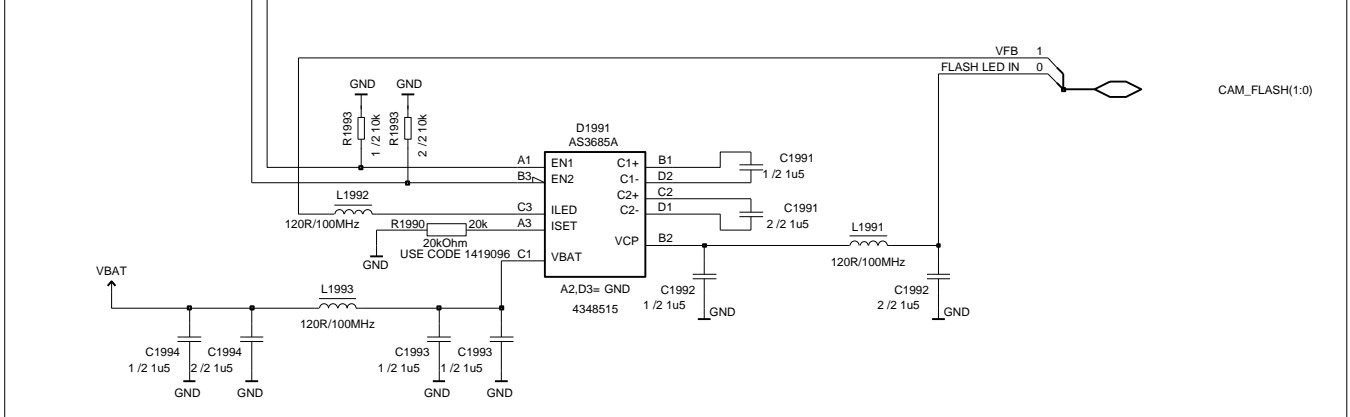

- CAM_CTRL_CMT(8:0)
- PUSL(7:0)
- SPL_CMT(5:0)
- GEN_CTRL_CMT(20:0)

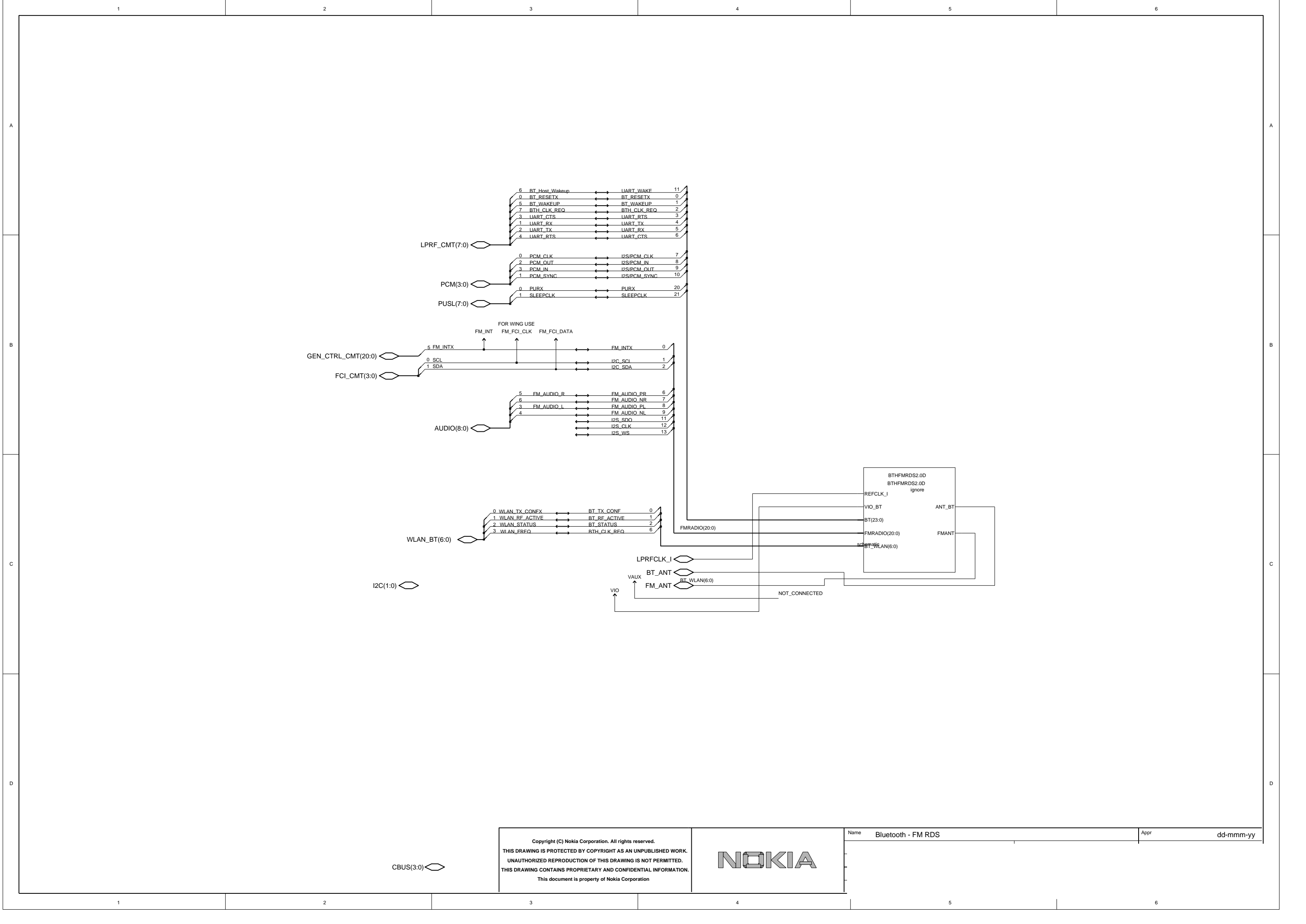

Copyright (C) Nokia Corporation. All rights reserved.
 THIS DRAWING IS PROTECTED BY COPYRIGHT AS AN UNPUBLISHED WORK.
 UNAUTHORIZED REPRODUCTION OF THIS DRAWING IS NOT PERMITTED.
 THIS DRAWING CONTAINS PROPRIETARY AND CONFIDENTIAL INFORMATION.
 This document is property of Nokia Corporation



Name Bluetooth - FM RDS
 Appr dd-mmm-yy

CBUS(3:0)

DISPLAY_KEYBOARD

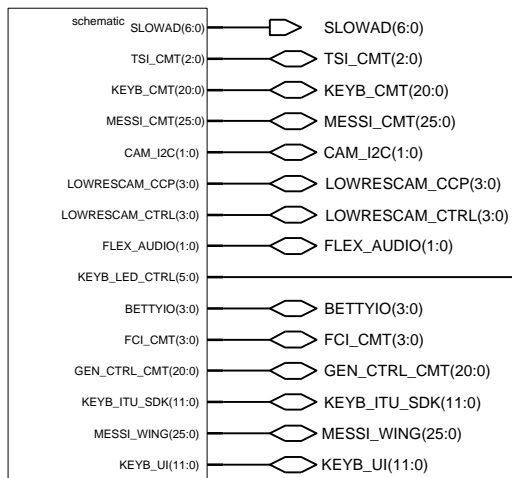

2400-2499

2450-2499

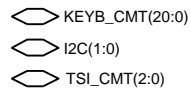

SENSORS

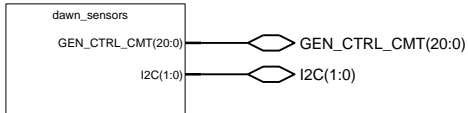

2550-2599

DISPLAY

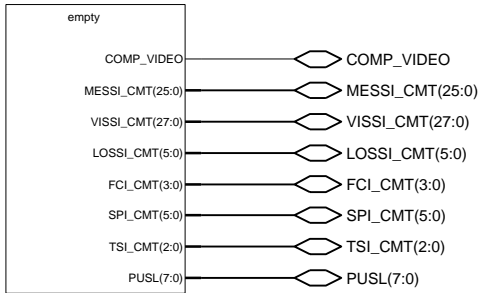

2400-2449

KEYB_LED_CTRL(5:0) to KEYB_LED_CTRL(5:0)

Side and navi key backlight

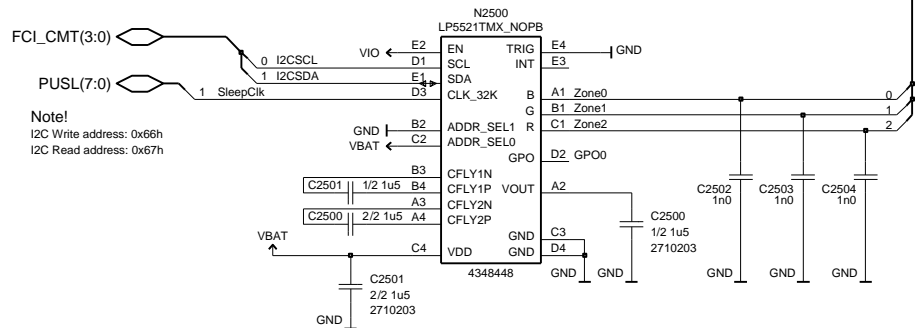

Note!

I2C Write address: 0x66h

I2C Read address: 0x67h

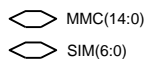
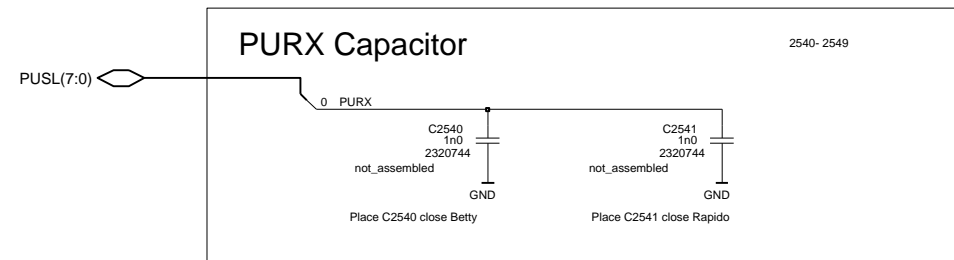
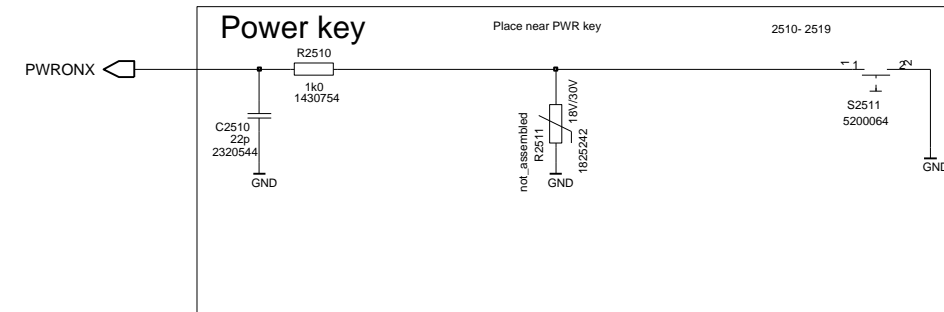

Copyright (C) Nokia Corporation. All rights reserved.
 THIS DRAWING IS PROTECTED BY COPYRIGHT AS AN UNPUBLISHED WORK.
 UNAUTHORIZED REPRODUCTION OF THIS DRAWING IS NOT PERMITTED.
 THIS DRAWING CONTAINS PROPRIETARY AND CONFIDENTIAL INFORMATION.
 This document is property of Nokia Corporation



Name UI parts Appr dd-mmm-yy

2400-2449

A

A

B

B

C

C

D

D

MESSI_CMT(25:0) 

 PUSL(7:0)

 VISSL_CMT(27:0)

 LOSSI_CMT(5:0)

 SPI_CMT(5:0)

 FCI_CMT(3:0)

 TSI_CMT(2:0)

 COMP_VIDEO

Copyright (C) Nokia Corporation. All rights reserved.
 THIS DRAWING IS PROTECTED BY COPYRIGHT AS AN UNPUBLISHED WORK.
 UNAUTHORIZED REPRODUCTION OF THIS DRAWING IS NOT PERMITTED.
 THIS DRAWING CONTAINS PROPRIETARY AND CONFIDENTIAL INFORMATION.
 This document is property of Nokia Corporation



Name Display

Appr dd-mmm-yy

UI Flex Connector

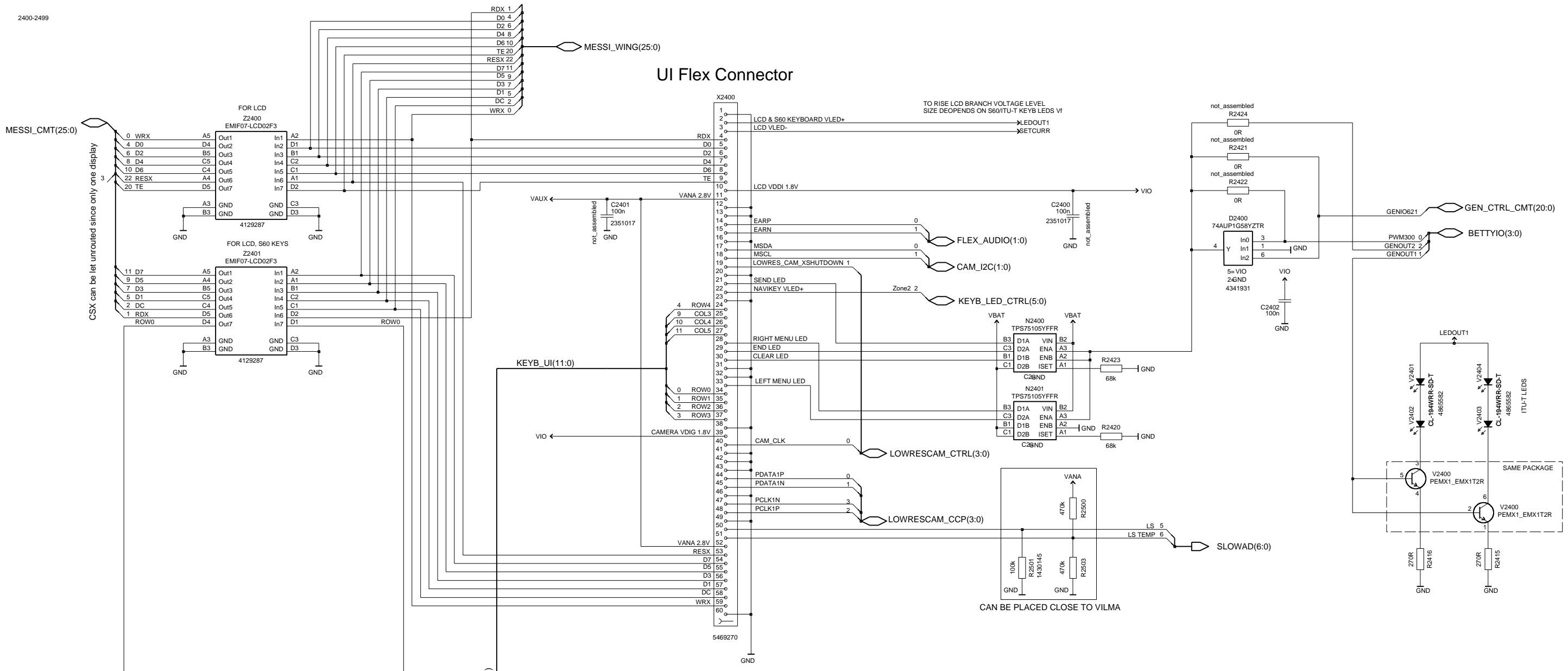

ROW
Row/column order must be as shown
in figure to minimize interference
from RF and other sources to keyboard

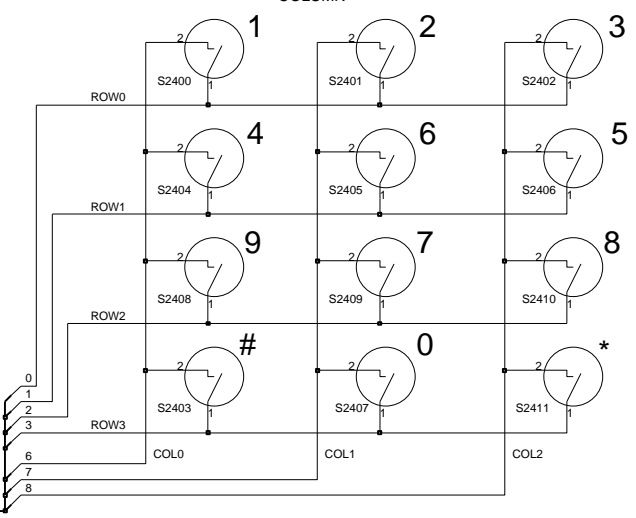

FCI_CMT(3:0)
TSL_CMT(2:0)

Copyright (C) Nokia Corporation. All rights reserved.
THIS DRAWING IS PROTECTED BY COPYRIGHT AS AN UNPUBLISHED WORK.
UNAUTHORIZED REPRODUCTION OF THIS DRAWING IS NOT PERMITTED.
THIS DRAWING CONTAINS PROPRIETARY AND CONFIDENTIAL INFORMATION.
This document is property of Nokia Corporation

Name: Display and keyboard
Appr: dd-mmm-yy

2550- 2599

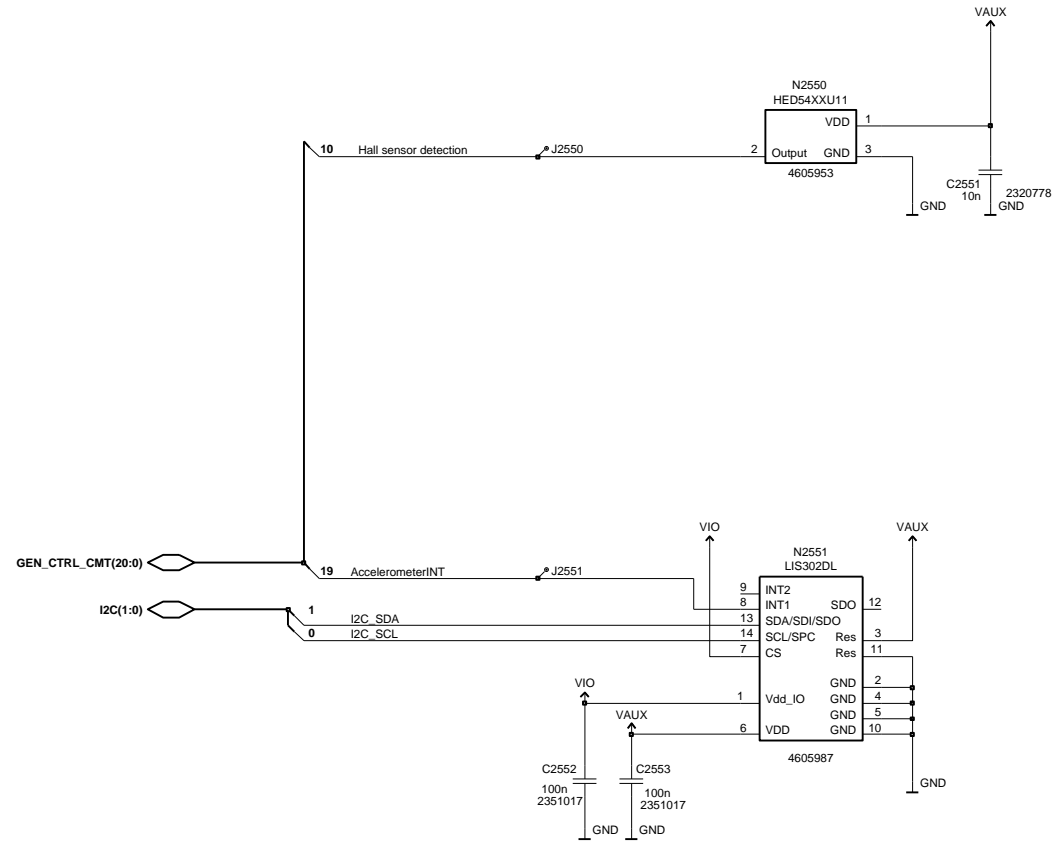

Copyright (C) Nokia Corporation. All rights reserved.
THIS DRAWING IS PROTECTED BY COPYRIGHT AS AN UNPUBLISHED WORK.
UNAUTHORIZED REPRODUCTION OF THIS DRAWING IS NOT PERMITTED.
THIS DRAWING CONTAINS PROPRIETARY AND CONFIDENTIAL INFORMATION.
This document is property of Nokia Corporation



Name Sensors Appr dd-mmm-yy

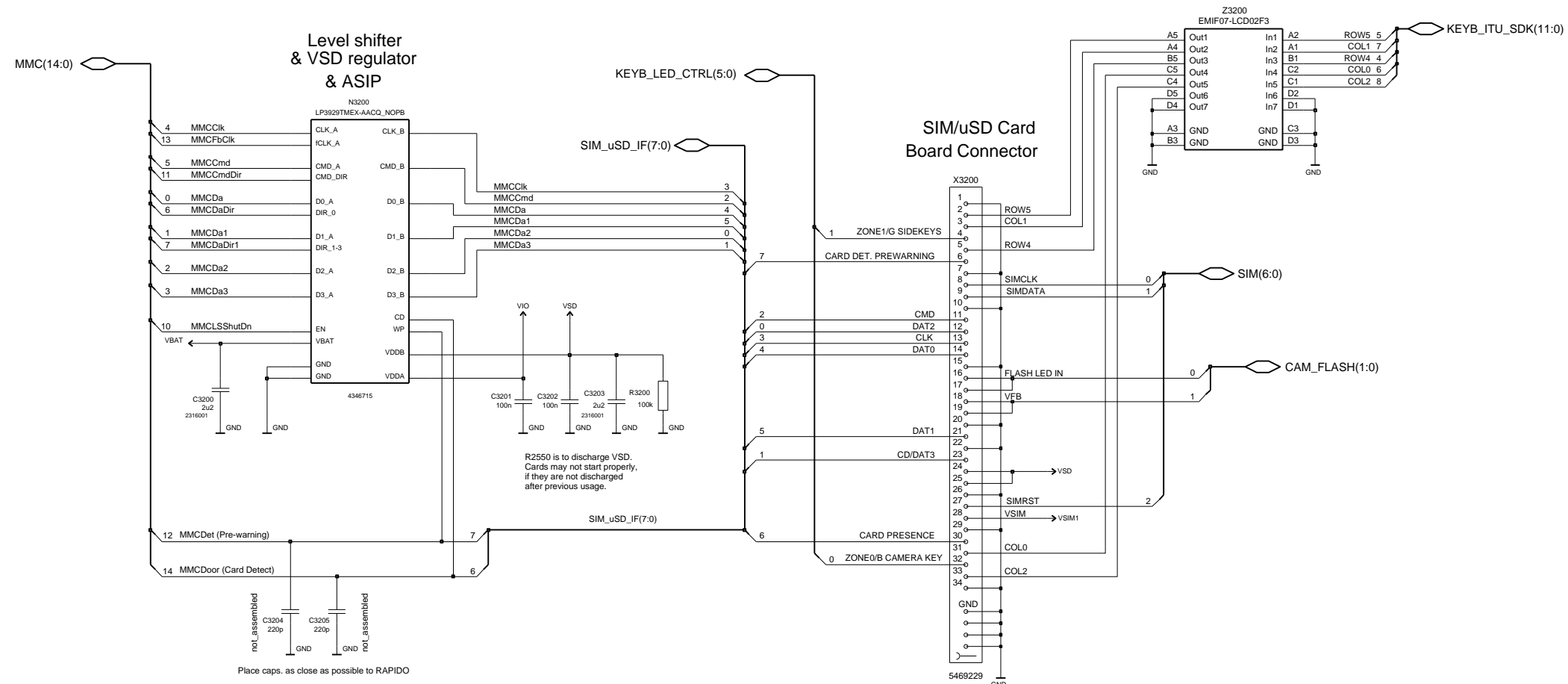

Copyright (C) Nokia Corporation. All rights reserved.
 THIS DRAWING IS PROTECTED BY COPYRIGHT AS AN UNPUBLISHED WORK.
 UNAUTHORIZED REPRODUCTION OF THIS DRAWING IS NOT PERMITTED.
 THIS DRAWING CONTAINS PROPRIETARY AND CONFIDENTIAL INFORMATION.
 This document is property of Nokia Corporation



Name SD card
 Appr dd-mmm-yy

6300-6399

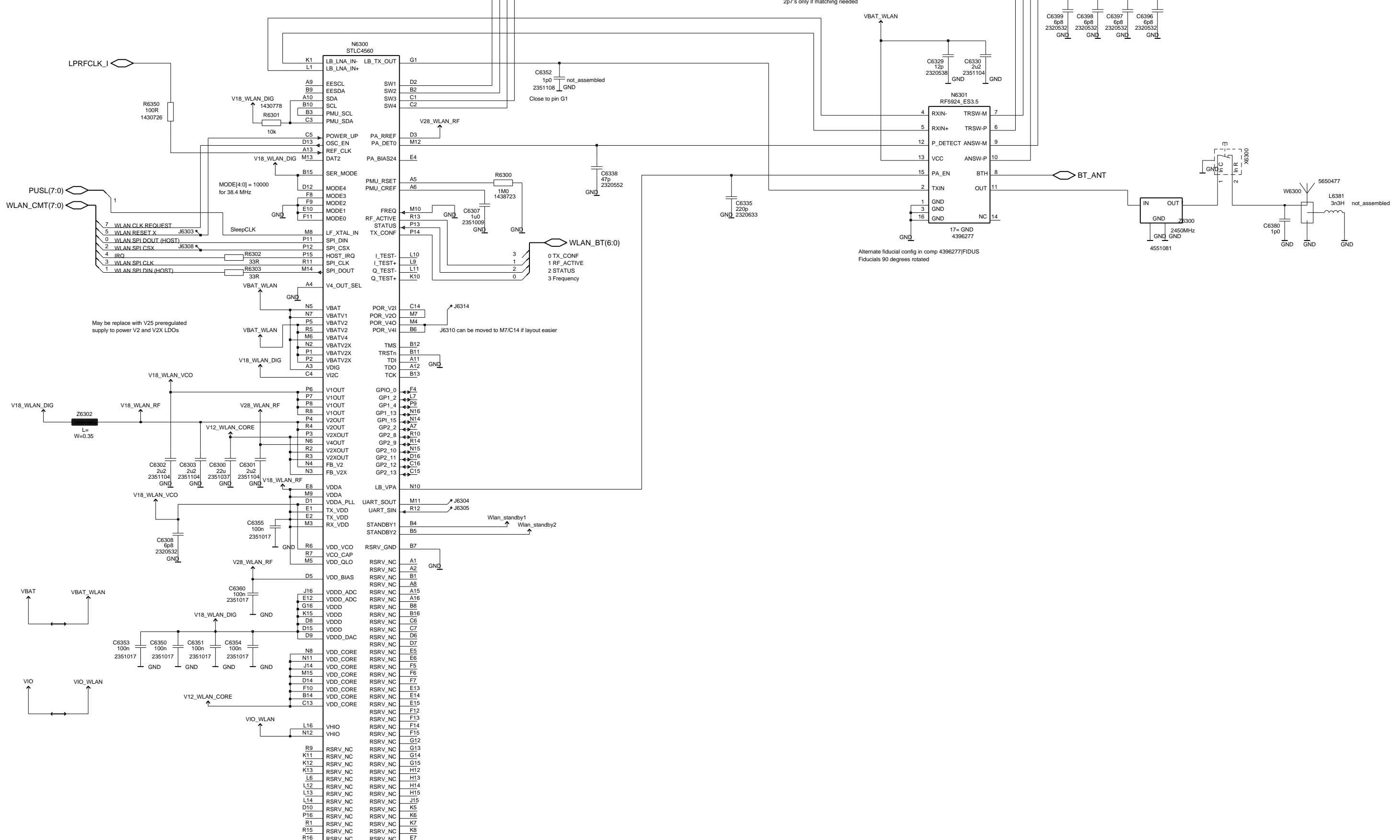

- BT_ANT
- WLAN_BT(6:0)
- PUSL(7:0)

GND PINS= GND
4390002

Copyright (C) Nokia Corporation. All rights reserved.
THIS DRAWING IS PROTECTED BY COPYRIGHT AS AN UNPUBLISHED WORK.
UNAUTHORIZED REPRODUCTION OF THIS DRAWING IS NOT PERMITTED.
THIS DRAWING CONTAINS PROPRIETARY AND CONFIDENTIAL INFORMATION.
This document is property of Nokia Corporation



Name WLAN Appr dd-mmm-yy

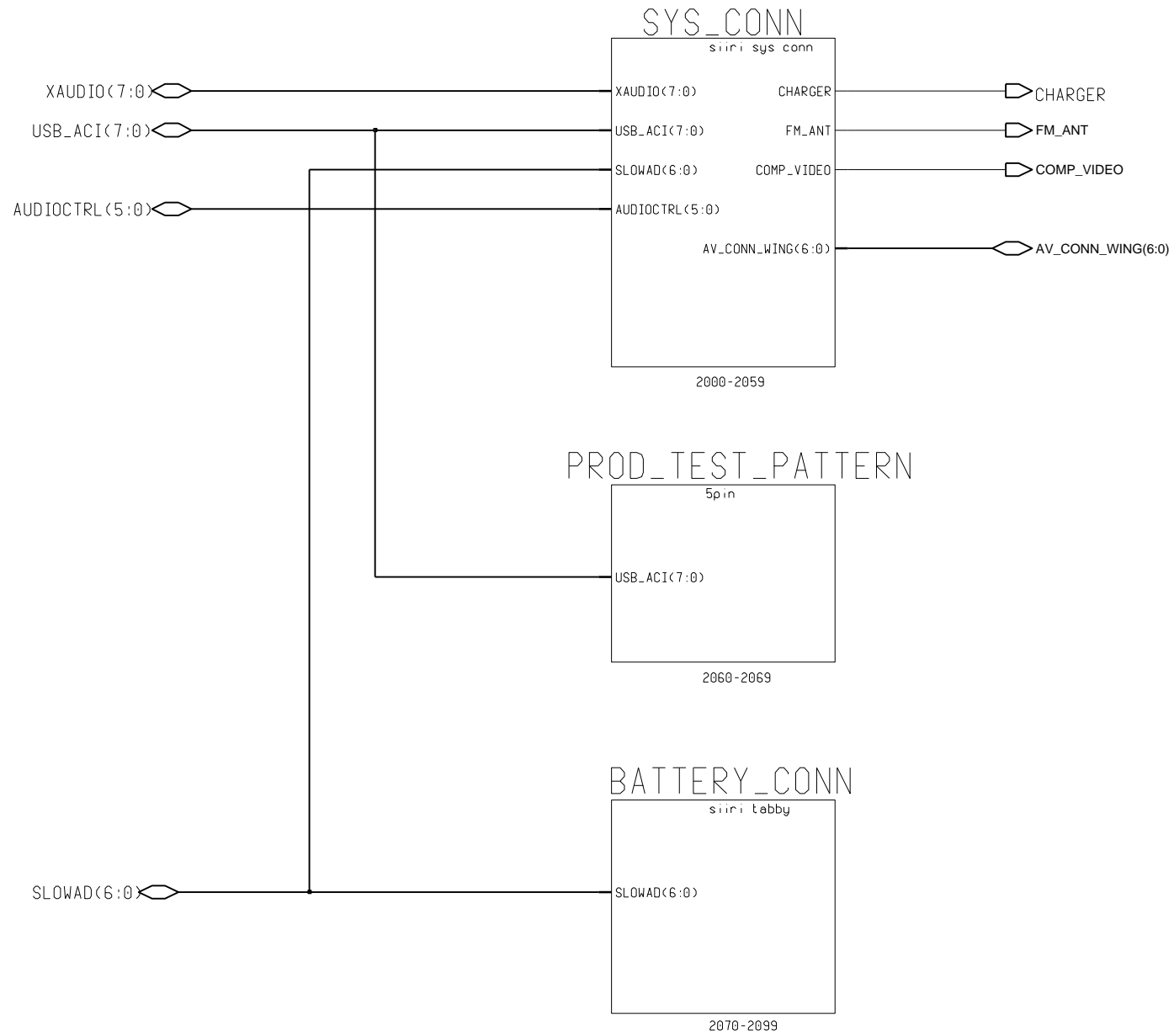

Copyright (C) Nokia Corporation. All rights reserved.
 THIS DRAWING IS PROTECTED BY COPYRIGHT AS AN UNPUBLISHED WORK.
 UNAUTHORIZED REPRODUCTION OF THIS DRAWING IS NOT PERMITTED.
 THIS DRAWING CONTAINS PROPRIETARY AND CONFIDENTIAL INFORMATION.
 This document is property of Nokia Corporation



Name	System and battery connector	Appr	10-Aug-00
------	------------------------------	------	-----------

2070-2099

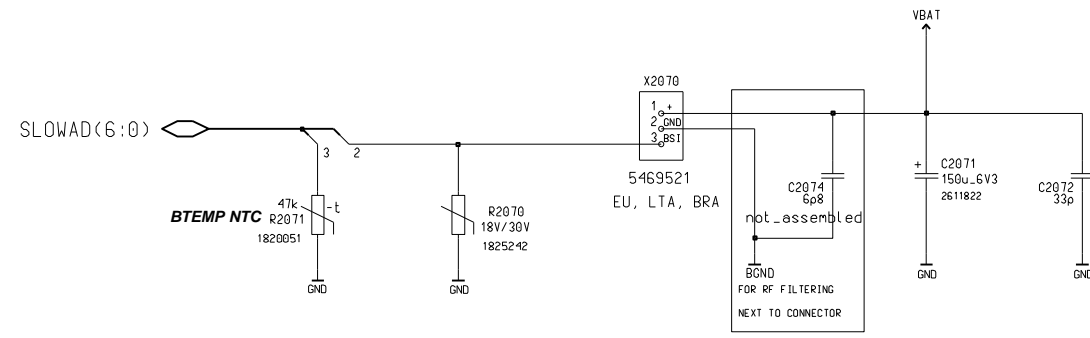

Copyright (C) Nokia Corporation. All rights reserved.
THIS DRAWING IS PROTECTED BY COPYRIGHT AS AN UNPUBLISHED WORK.
UNAUTHORIZED REPRODUCTION OF THIS DRAWING IS NOT PERMITTED.
THIS DRAWING CONTAINS PROPRIETARY AND CONFIDENTIAL INFORMATION.
This document is property of Nokia Corporation



Name Battery Connector

Appr 10-Aug-00

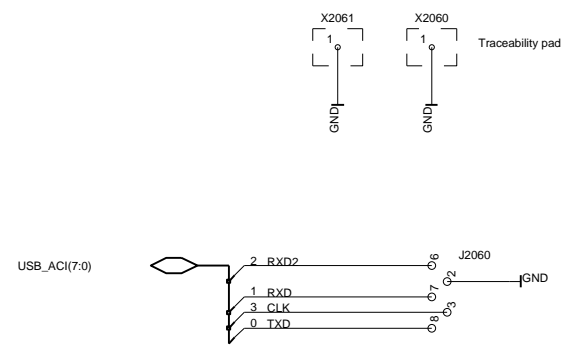

Copyright (C) Nokia Corporation. All rights reserved.
 THIS DRAWING IS PROTECTED BY COPYRIGHT AS AN UNPUBLISHED WORK.
 UNAUTHORIZED REPRODUCTION OF THIS DRAWING IS NOT PERMITTED.
 THIS DRAWING CONTAINS PROPRIETARY AND CONFIDENTIAL INFORMATION.
 This document is property of Nokia Corporation



Name	Production test pad	Appr	10-Aug-00
Assn			
File			
Proj			

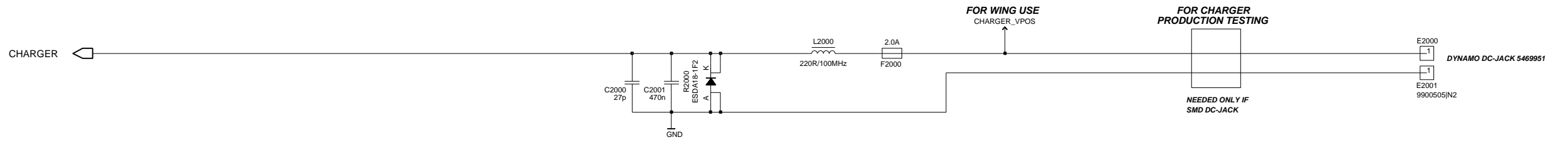

NOTE: This sheet requires AVILMA with external 2k bias resistor in VILMA sheet

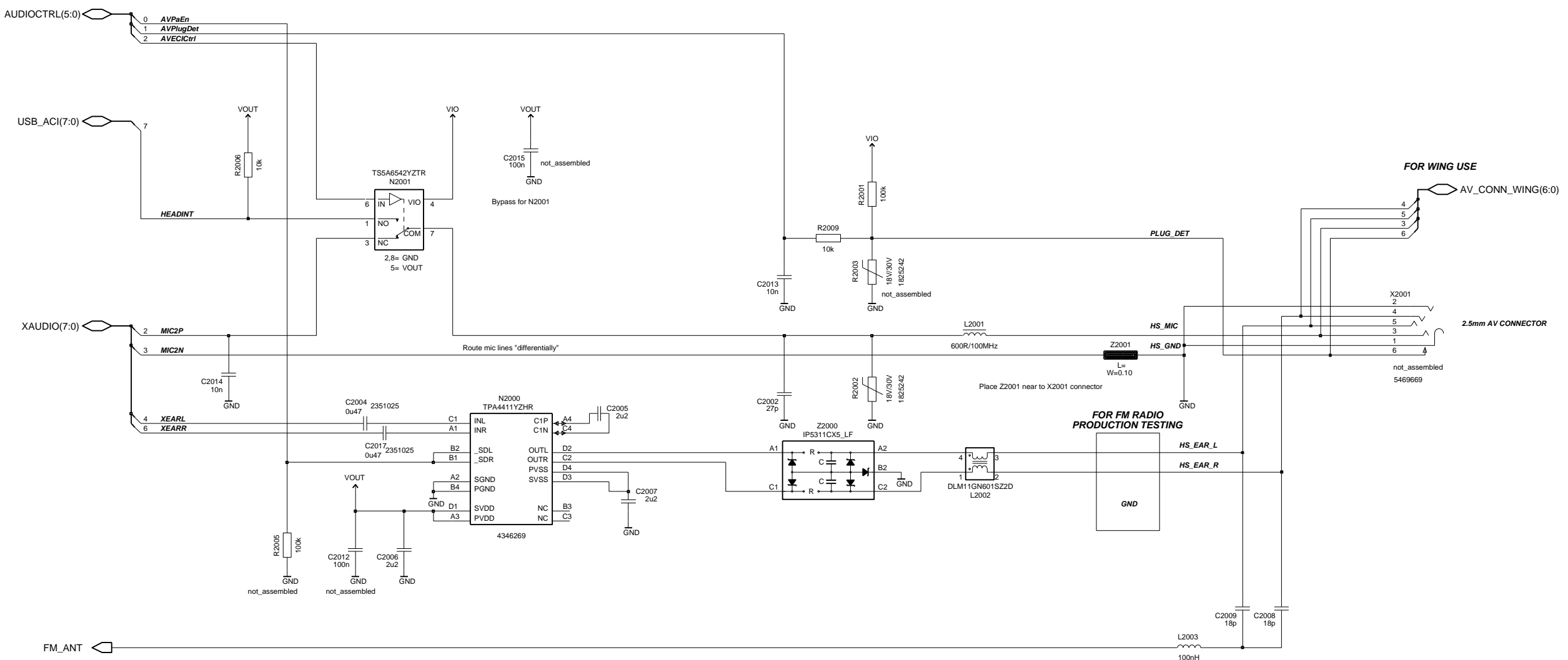

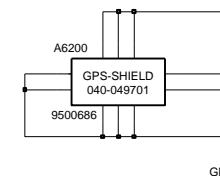
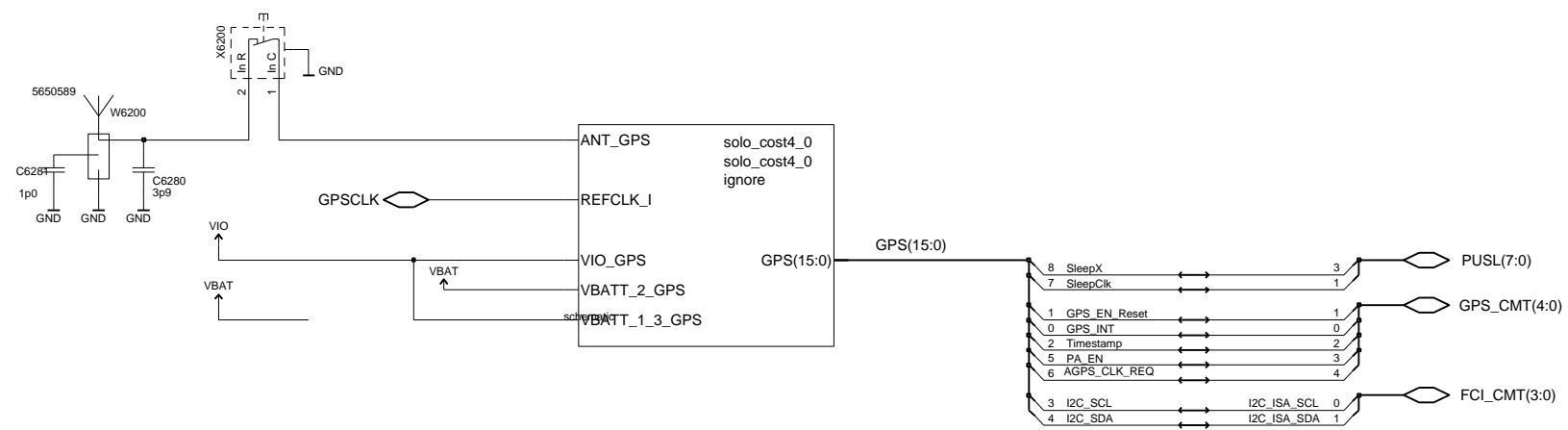

Copyright (C) Nokia Corporation. All rights reserved.
 THIS DRAWING IS PROTECTED BY COPYRIGHT AS AN UNPUBLISHED WORK.
 UNAUTHORIZED REPRODUCTION OF THIS DRAWING IS NOT PERMITTED.
 THIS DRAWING CONTAINS PROPRIETARY AND CONFIDENTIAL INFORMATION.
 This document is property of Nokia Corporation



Name GPS Cost 3.0

Appr dd-mmm-yy

1

2

3

4

5

6

A

A

B

B

C

C

D

D

AV_CONN_WING(6:0) ◁

FLEX_AUDIO(1:0) ◁

KEYB_UI(11:0) ◁

MESSI_WING(25:0) ◁

CAM_I2C(1:0) ◁

LOWRESCAM_CCP(3:0) ◁

LOWRESCAM_CTRL(3:0) ◁

KEYB_ITU_SDK(11:0) ◁

KEYB_LED_CTRL(5:0) ◁

CAM_FLASH(1:0) ◁

SIM_uSD_IF(7:0) ◁

WING_USB(5:0) ◁

SLOWAD(6:0) ◁

KEYB_CMT(20:0) ◁

FCL_CMT(3:0) ◁

SIM(6:0) ◁

MESSI_CMT(25:0) ◁

GEN_CTRL_CMT(20:0) ◁

PWRONX ◁

<p>Copyright (C) Nokia Corporation. All rights reserved. THIS DRAWING IS PROTECTED BY COPYRIGHT AS AN UNPUBLISHED WORK. UNAUTHORIZED REPRODUCTION OF THIS DRAWING IS NOT PERMITTED. THIS DRAWING CONTAINS PROPRIETARY AND CONFIDENTIAL INFORMATION. This document is property of Nokia Corporation</p>		<p>Name Wing UI</p>	<p>Appr dd-mmm-yy</p>
------------------------------------------------------------------------------------------------------------------------------------------------------------------------------------------------------------------------------------------------------------------------------------------------------------------------------------------------------------	---------------------------------------------------------------------------------------	---------------------	-----------------------

1

2

3

4

1

2

3

4

5

6

2700-2799

SIMIF(6.0)



A

A

B

B

C

C

D

D

Copyright (C) Nokia Corporation. All rights reserved.
 THIS DRAWING IS PROTECTED BY COPYRIGHT AS AN UNPUBLISHED WORK.
 UNAUTHORIZED REPRODUCTION OF THIS DRAWING IS NOT PERMITTED.
 THIS DRAWING CONTAINS PROPRIETARY AND CONFIDENTIAL INFORMATION.
 This document is property of Nokia Corporation



Name SIM interface

Appr 10-Aug-00

1











2

3

4

5

6

- GEN_CTRL_CMT(20:0) 
- MESSI_CMT(25:0) 
- KEYB_CMT(20:0) 
- PUSL(7:0) 
- USB_ACI(7:0) 
- SLOWAD(6:0) 
- PCM(3:0) 
- LPRF_CMT(7:0) 
- WLAN_CMT(7:0) 
- BT_TEST(15:0) 
- WLAN_BT(6:0) 

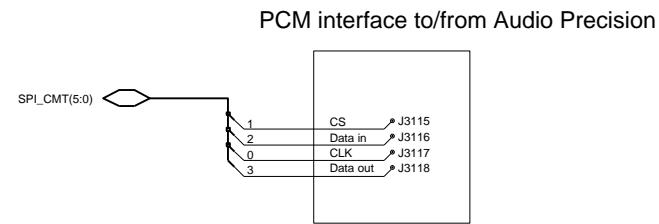
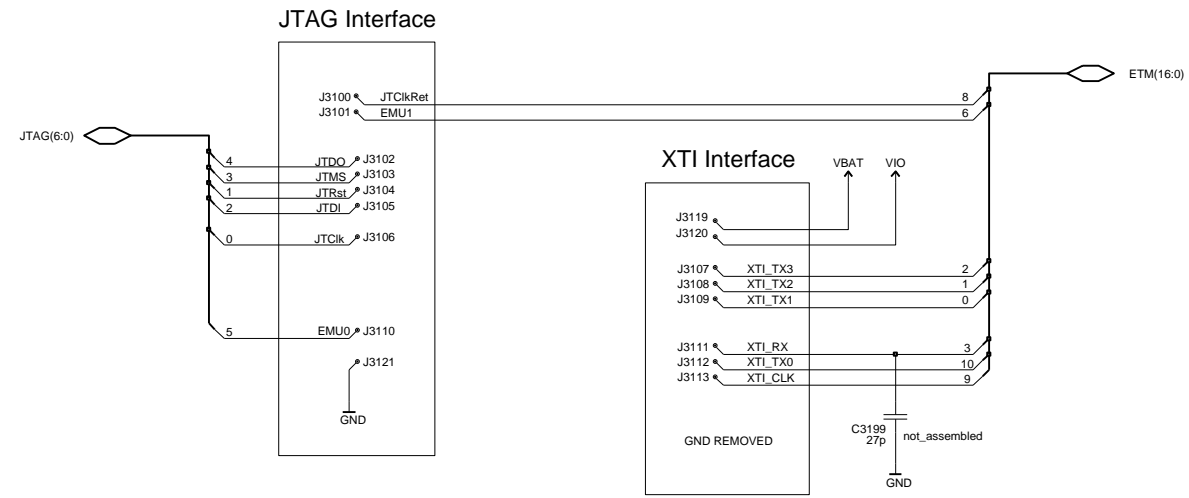

Copyright (C) Nokia Corporation. All rights reserved.
 THIS DRAWING IS PROTECTED BY COPYRIGHT AS AN UNPUBLISHED WORK.
 UNAUTHORIZED REPRODUCTION OF THIS DRAWING IS NOT PERMITTED.
 THIS DRAWING CONTAINS PROPRIETARY AND CONFIDENTIAL INFORMATION.
 This document is property of Nokia Corporation



Name EMU:RAP Test Interface

Appr dd-mmm-yy

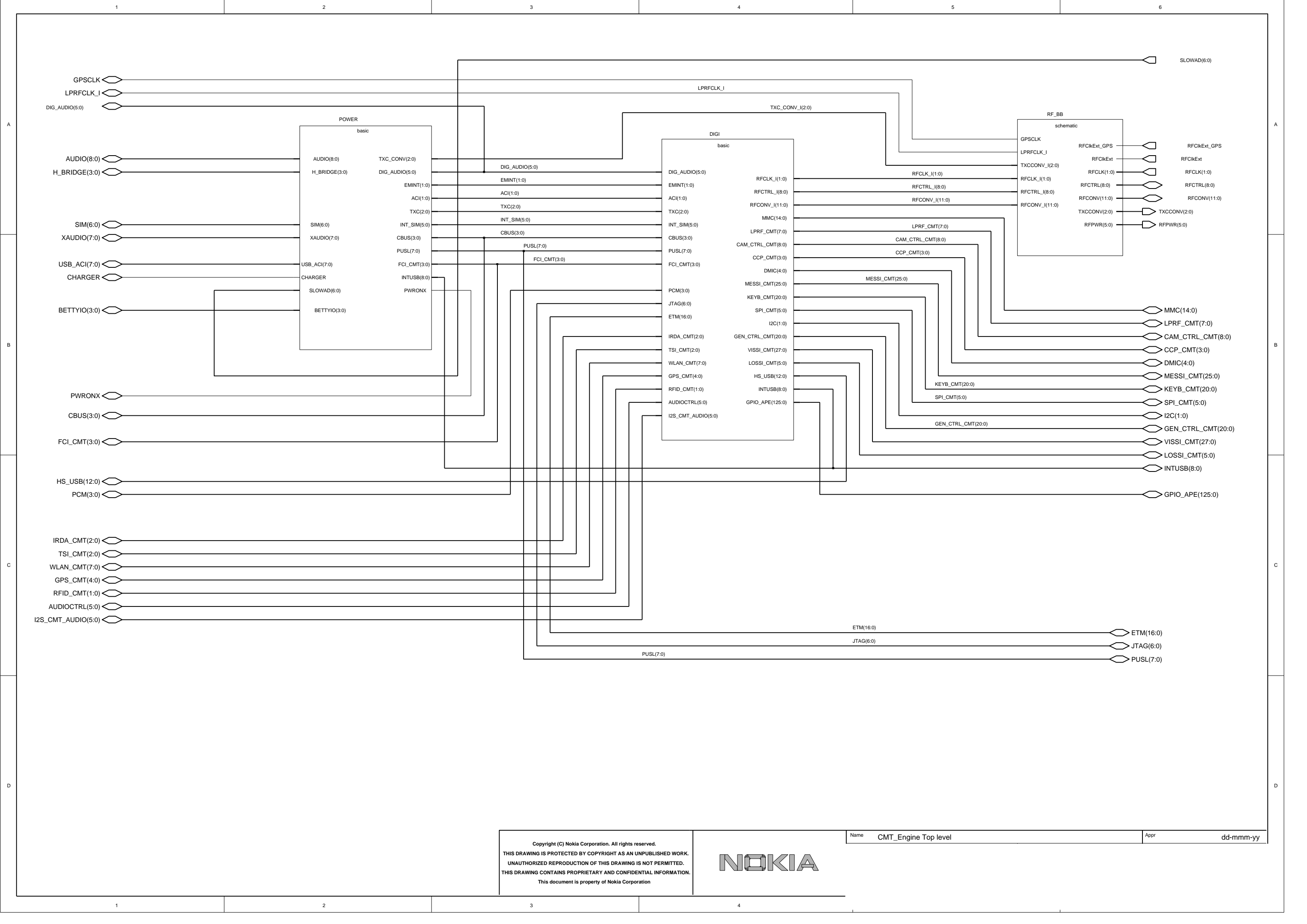

Copyright (C) Nokia Corporation. All rights reserved.
 THIS DRAWING IS PROTECTED BY COPYRIGHT AS AN UNPUBLISHED WORK.
 UNAUTHORIZED REPRODUCTION OF THIS DRAWING IS NOT PERMITTED.
 THIS DRAWING CONTAINS PROPRIETARY AND CONFIDENTIAL INFORMATION.
 This document is property of Nokia Corporation



Name CMT_Engine Top level Appr dd-mmm-yy

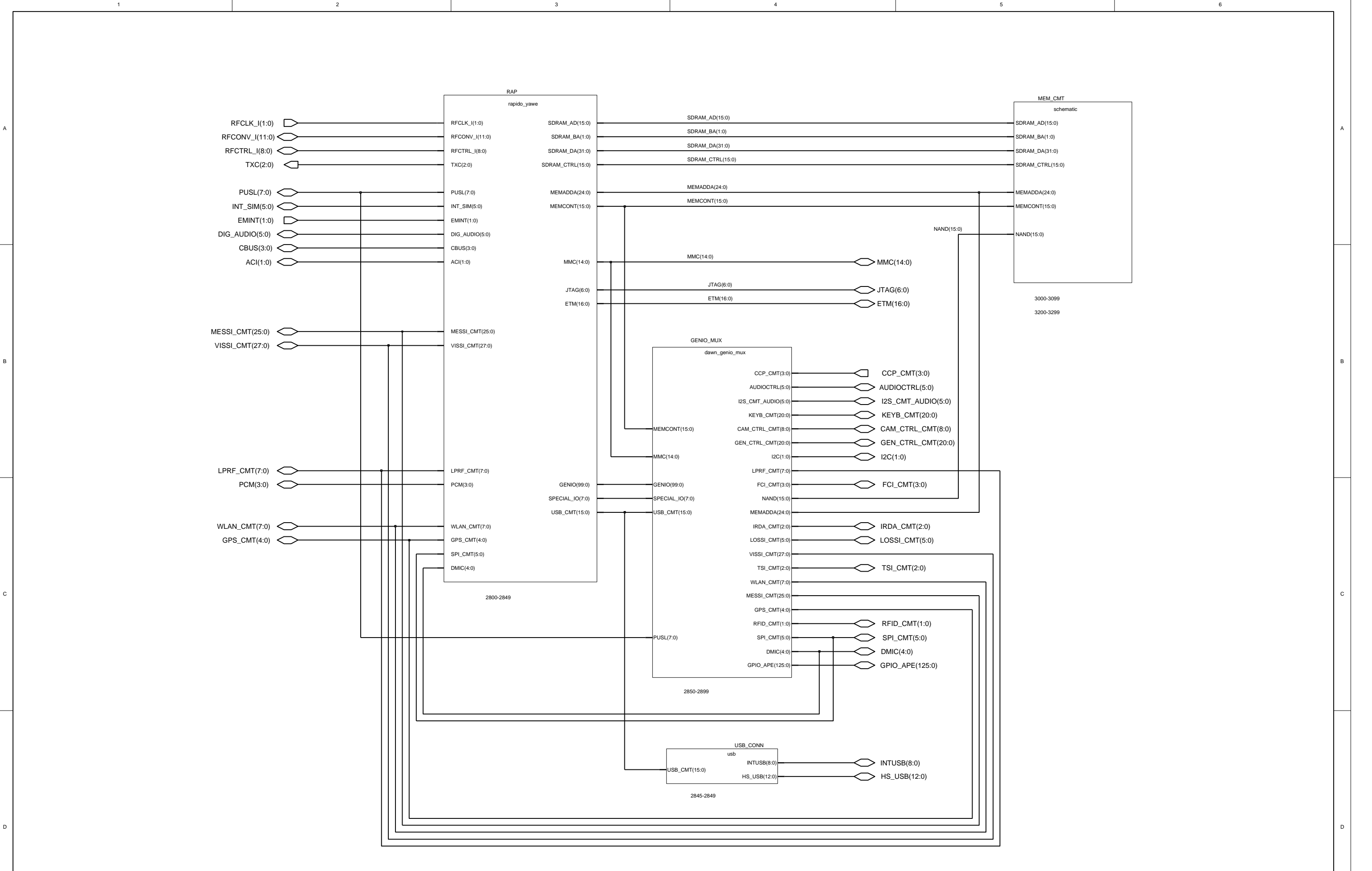

Copyright (C) Nokia Corporation. All rights reserved.
 THIS DRAWING IS PROTECTED BY COPYRIGHT AS AN UNPUBLISHED WORK.
 UNAUTHORIZED REPRODUCTION OF THIS DRAWING IS NOT PERMITTED.
 THIS DRAWING CONTAINS PROPRIETARY AND CONFIDENTIAL INFORMATION.
 This document is property of Nokia Corporation



Name CMT SUBSYSTEM

Appr dd-mmm-yy

2845-2849

HS_USB(12:0)

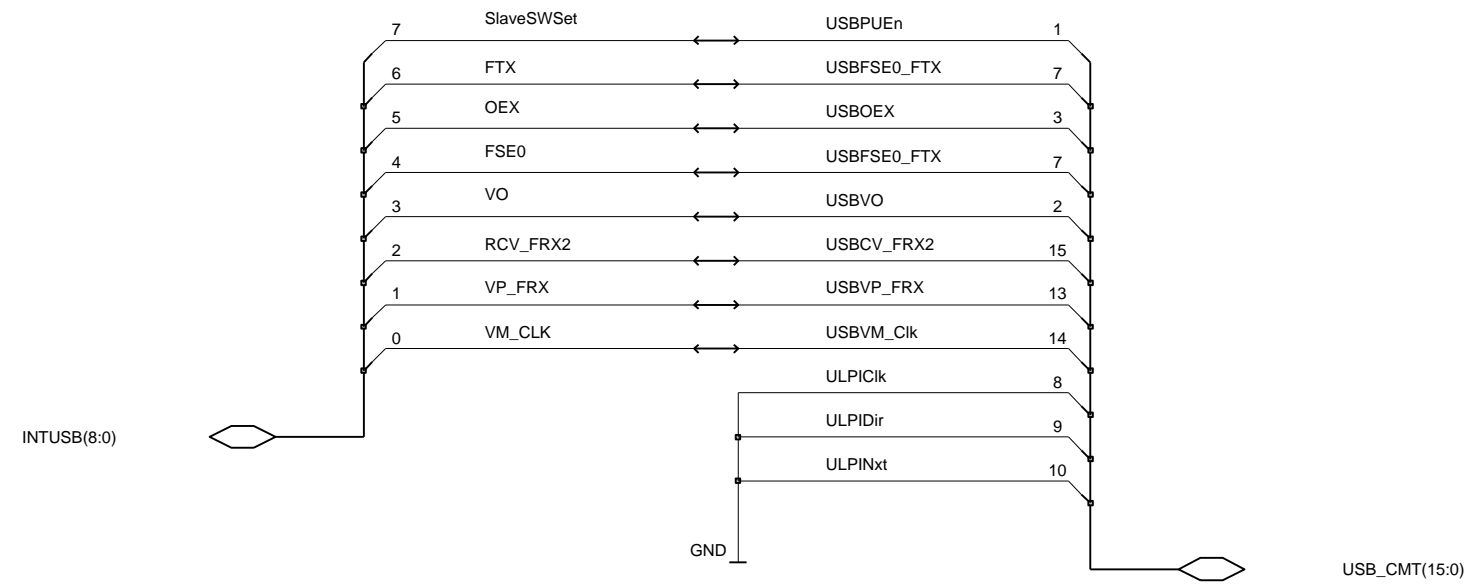

Copyright (C) Nokia Corporation. All rights reserved.
 THIS DRAWING IS PROTECTED BY COPYRIGHT AS AN UNPUBLISHED WORK.
 UNAUTHORIZED REPRODUCTION OF THIS DRAWING IS NOT PERMITTED.
 THIS DRAWING CONTAINS PROPRIETARY AND CONFIDENTIAL INFORMATION.
 This document is property of Nokia Corporation

Name USB Appr dd-mmm-yy

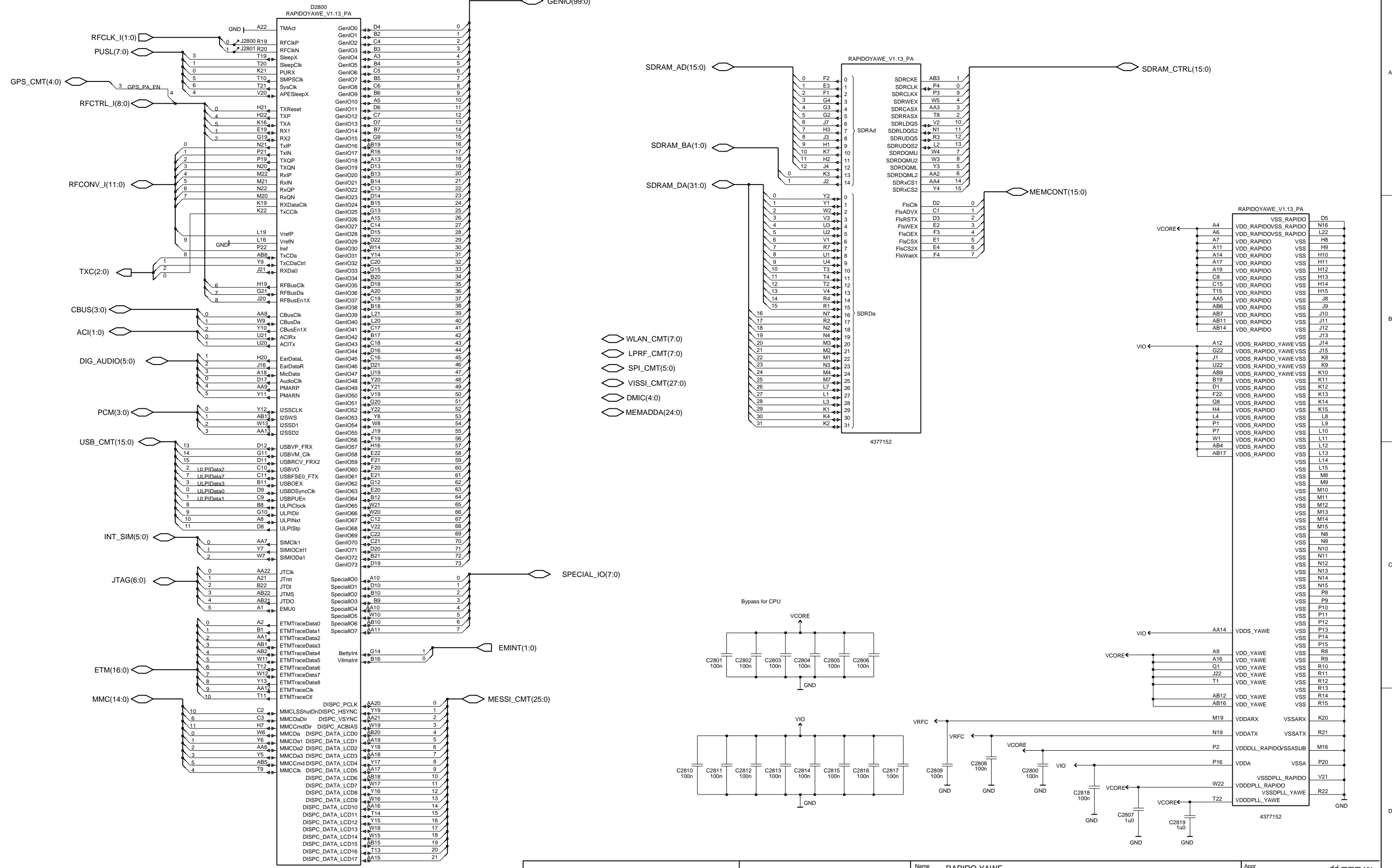

Copyright (C) Nokia Corporation. All rights reserved.
 THIS DRAWING IS PROTECTED BY COPYRIGHT AS AN UNPUBLISHED WORK.
 UNAUTHORIZED REPRODUCTION OF THIS DRAWING IS NOT PERMITTED.
 THIS DRAWING CONTAINS PROPRIETARY AND CONFIDENTIAL INFORMATION.
 This document is property of Nokia Corporation



Dawn

- I2S_CMT_AUDIO(5:0)
- LOSSI_CMT(5:0)
- VISSI_CMT(27:0)
- NAND(15:0)
- USB_CMT(15:0)

- RFID_CMT(1:0)
- GPIO_APE(125:0)
- SPECIAL_IO(7:0)

GENIO(99:0)

SPECIAL_IO(7:0)

PUSL(7:0)

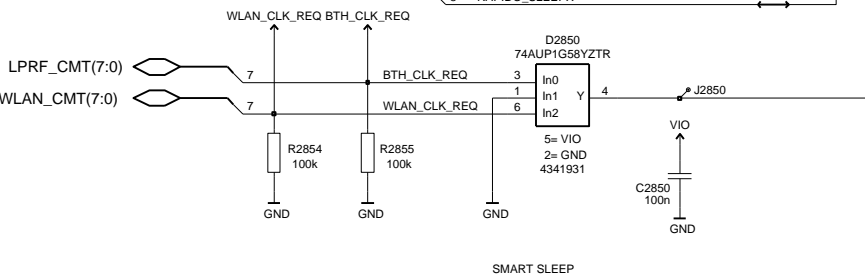

0	genio0	MEMADDA0
1	genio1	MEMADDA1
2	genio2	MEMADDA2
3	genio3	MEMADDA3
4	genio4	MEMADDA4
5	genio5	MEMADDA5
6	genio6	MEMADDA6
7	genio7	MEMADDA7
8	genio8	MEMADDA8
9	genio9	MEMADDA9
10	genio10	MEMADDA10
11	genio11	MEMADDA11
12	genio12	MEMADDA12
13	genio13	MEMADDA13
14	genio14	MEMADDA14
15	genio15	MEMADDA15
16	genio16	GPS_ENABLE
17	genio17	Plug_det
18	genio18	Audio_PA_EN
19	genio19	Audio_data_CTRL
20	genio20	FM_Int
21	genio21	BT_Wake_up
22	genio22	FlashINT
23	genio23	NOT CONNECTED
24	genio24	MMCDor
25	genio25	AGPS_CLK_REQ
26	genio26	KEYB COL0
27	genio27	LDO_STBY
28	genio28	CAM_VCTRL
29	genio29	WLAN_IRQ
30	genio30	I2C_SDA
31	genio31	I2C_SCL
32	genio32	KEYB ROW0
33	genio33	KEYB ROW1
34	genio34	KEYB ROW2
35	genio35	KEYB ROW3
36	genio36	KEYB ROW4
37	genio37	KEYB ROW5
38	genio38	KEYB COL1
39	genio39	KEYB COL2
40	genio40	KEYB COL3
41	genio41	KEYB COL4
42	genio42	DMIC_Data
43	genio43	WLAN_SPI_DIN
44	genio44	RESX
45	genio45	MMCDet
46	genio46	MMCDaDir1
47	genio47	KEYB COL5
48	genio48	I2C_ISA_SDA
49	genio49	LDO_EN
50	genio50	BT_UART_Wake
51	genio51	I2C_ISA_SCL
52	genio52	(Not in use - not allowed to use)
53	genio53	SLIDE_POSITION_DETECTION
54	genio54	WLAN_RESETX
55	genio55	ACCELEROMETER_INT
56	genio56	IRRX
57	genio57	IRTX
58	genio58	IRSD
59	genio59	BTDAIN
60	genio60	BTDOUT
61	genio61	GPS_TIMESTAMP
62	genio62	S60_LED_PWM_CTRL_DISABLE
63	genio63	WLAN_SPI_DOUT
64	genio64	NOT CONNECTED
65	genio65	BTRSTX
66	genio66	STV_PDN
67	genio67	NOT CONNECTED
68	genio68	CAMCLK
69	genio69	BTCTS
70	genio70	BTRTS
71	genio71	MMCFbClk
72	genio72	WLAN_SPI_CLK
73	genio73	WLAN_SPI_CSX

0	specialio0	CCPDaP
1	specialio1	CCPDaN
2	specialio2	CCPClkP
3	specialio3	CCPClkN
4	specialio4	SPI_CLK (Not in use)
5	specialio5	SPI_CS (Not in use)
6	specialio6	SPI_OUT (Not in use)
7	specialio7	SPI_IN (Not in use)

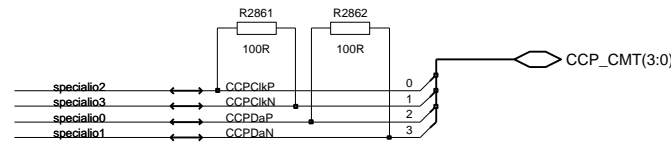
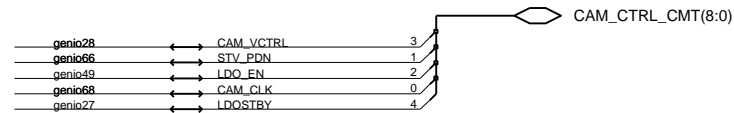
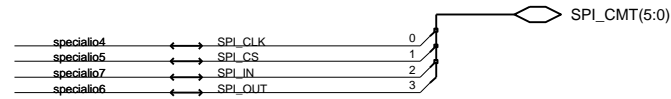
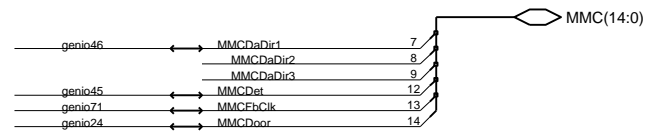
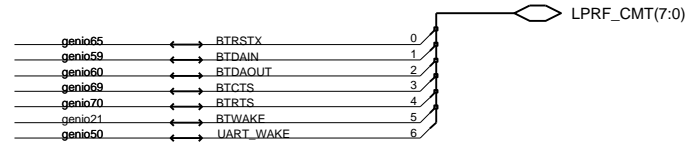
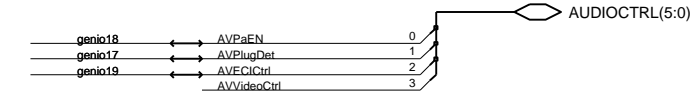
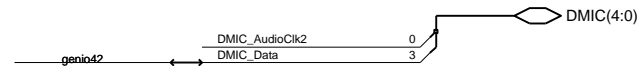

Place termination resistors R2861 and R2862 close Rapido

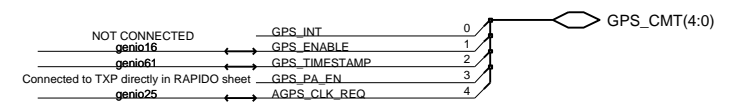
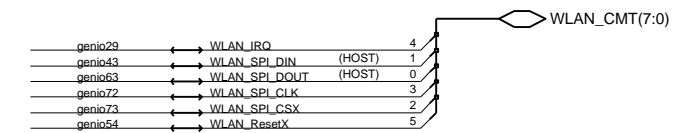
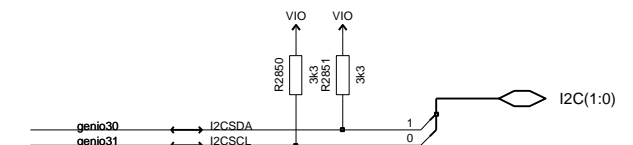
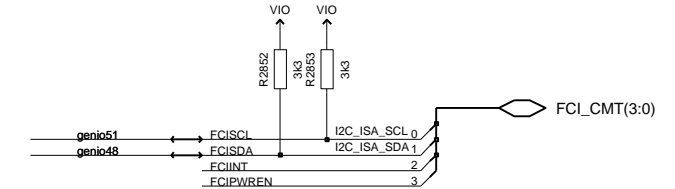
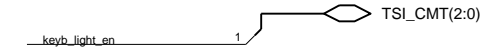
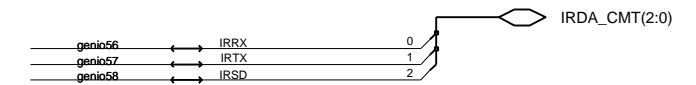
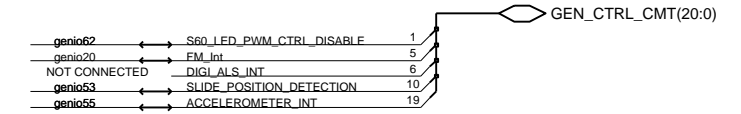
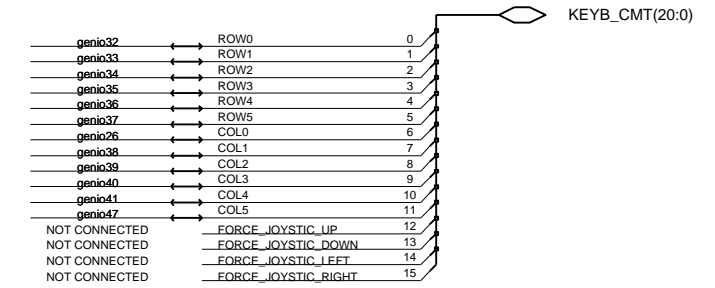
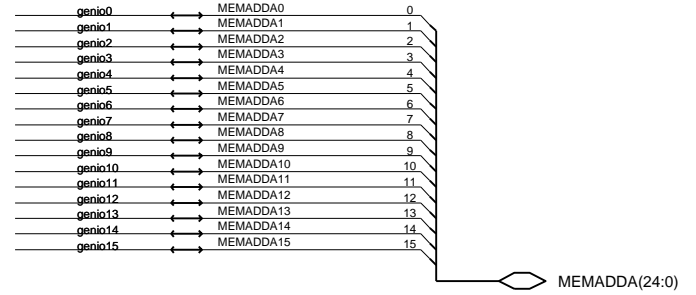

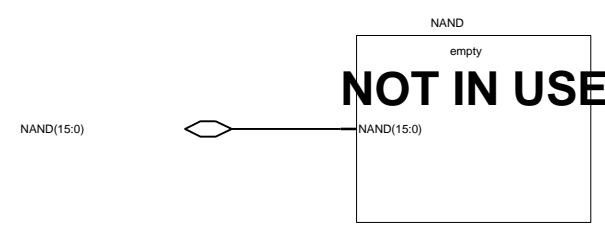
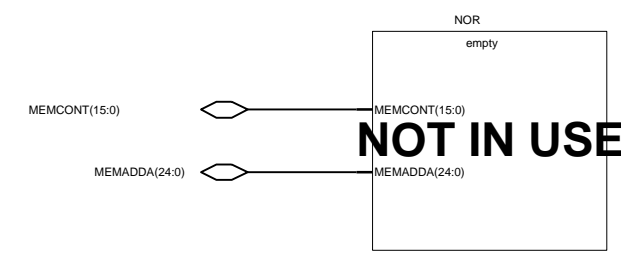
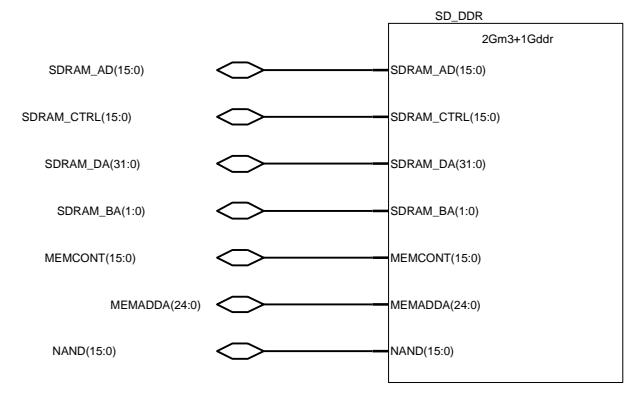

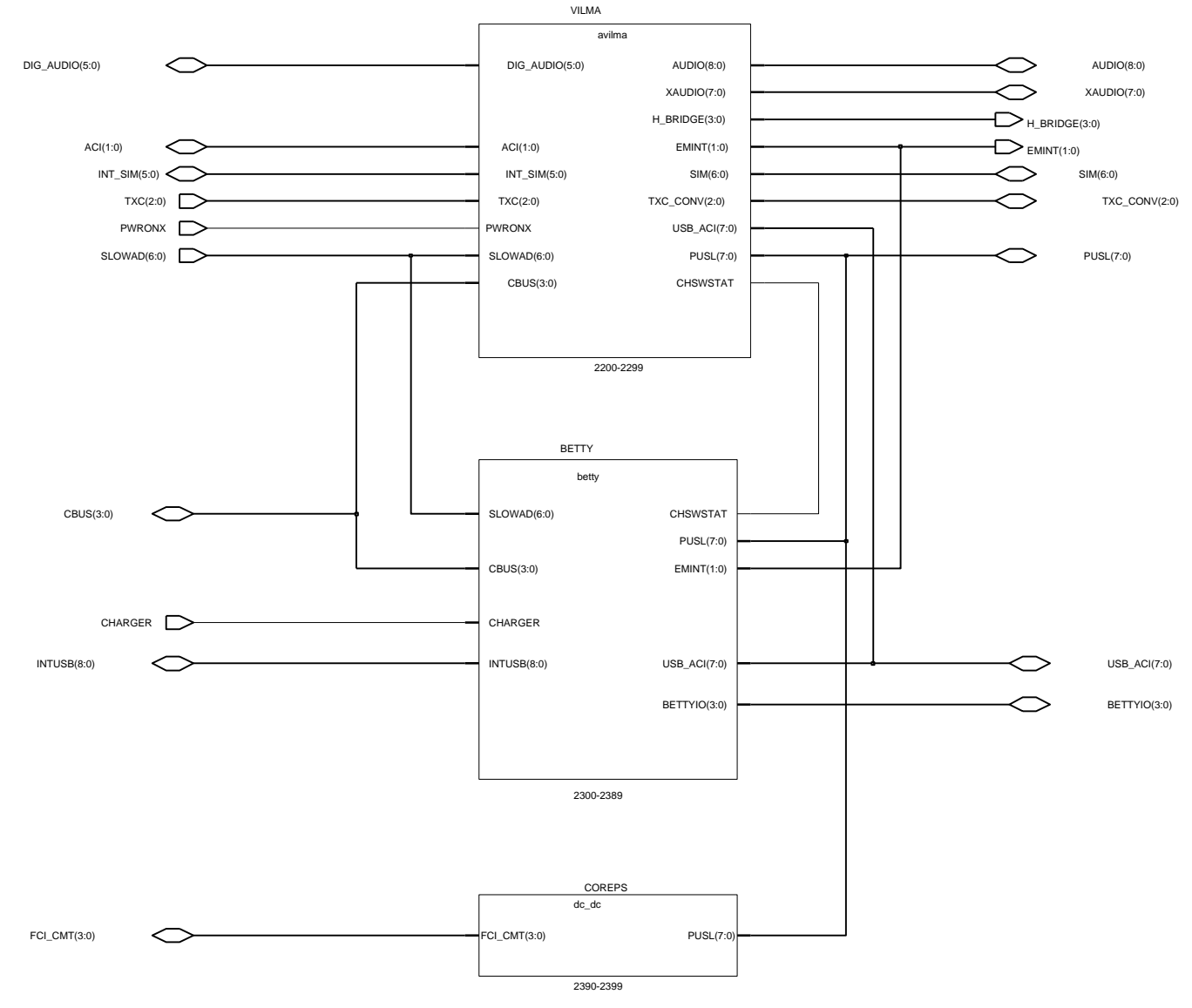

Copyright (C) Nokia Corporation. All rights reserved.
 THIS DRAWING IS PROTECTED BY COPYRIGHT AS AN UNPUBLISHED WORK.
 UNAUTHORIZED REPRODUCTION OF THIS DRAWING IS NOT PERMITTED.
 THIS DRAWING CONTAINS PROPRIETARY AND CONFIDENTIAL INFORMATION.
 This document is property of Nokia Corporation



Name Energy management

Appr dd-mmm-yy

External SMPS for VIO & VDRAM

AVILMA

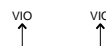

PUSL(7:0)

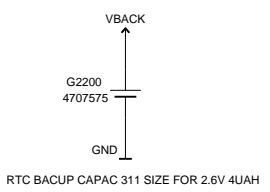
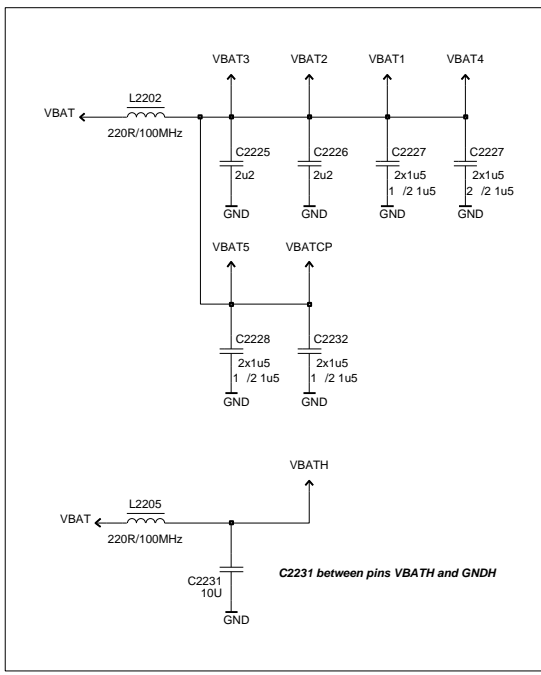
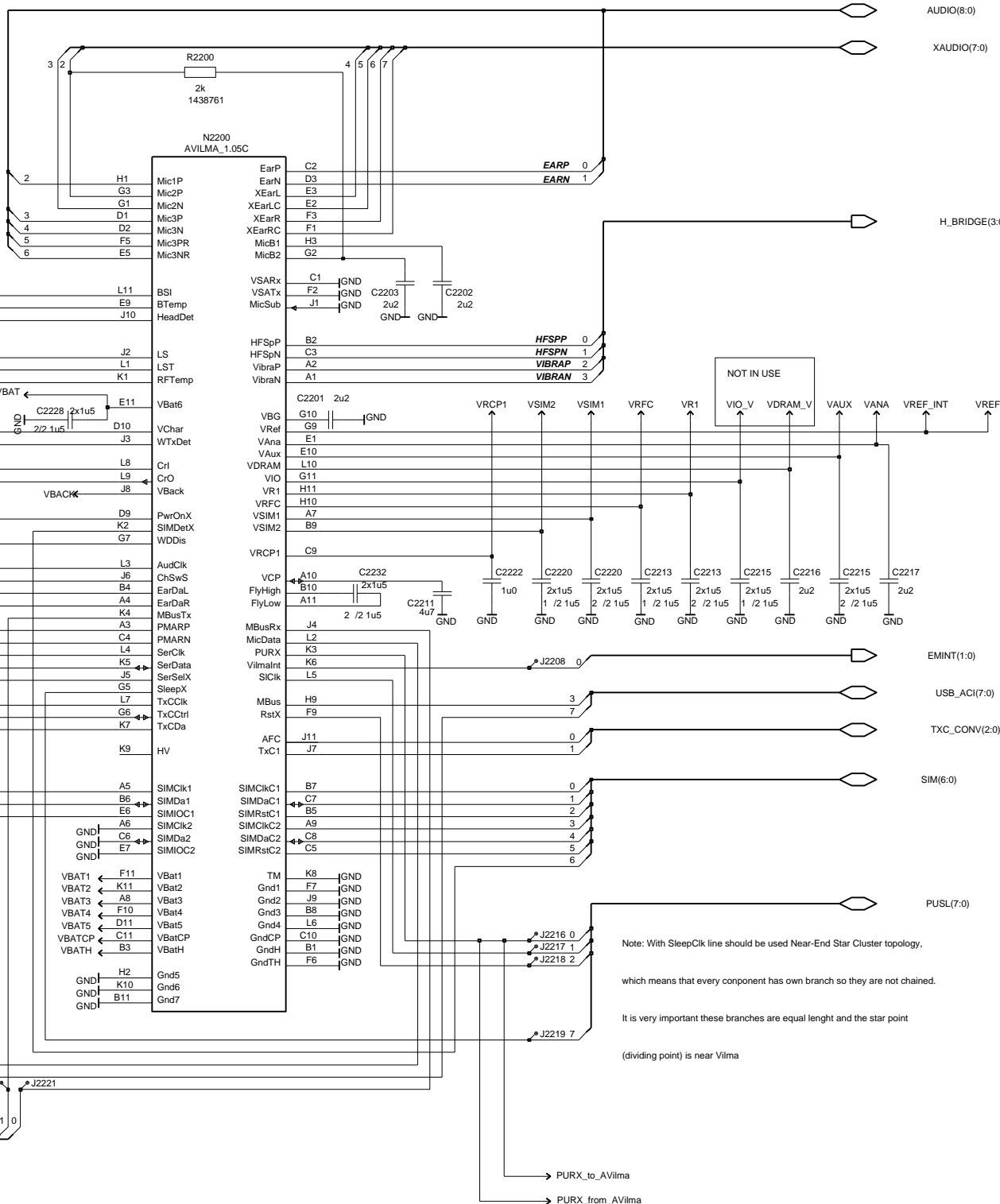
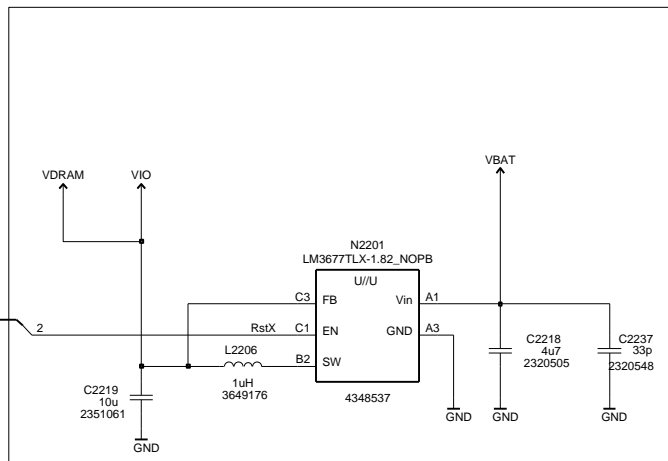

RTC BACUP CAPAC 311 SIZE FOR 2.6V 4UJAH

Note: With SleepClk line should be used Near-End Star Cluster topology, which means that every component has own branch so they are not chained. It is very important these branches are equal length and the star point (dividing point) is near Vilma

Copyright (C) Nokia Corporation. All rights reserved. THIS DRAWING IS PROTECTED BY COPYRIGHT AS AN UNPUBLISHED WORK. UNAUTHORIZED REPRODUCTION OF THIS DRAWING IS NOT PERMITTED. THIS DRAWING CONTAINS PROPRIETARY AND CONFIDENTIAL INFORMATION. This document is property of Nokia Corporation



BETTY

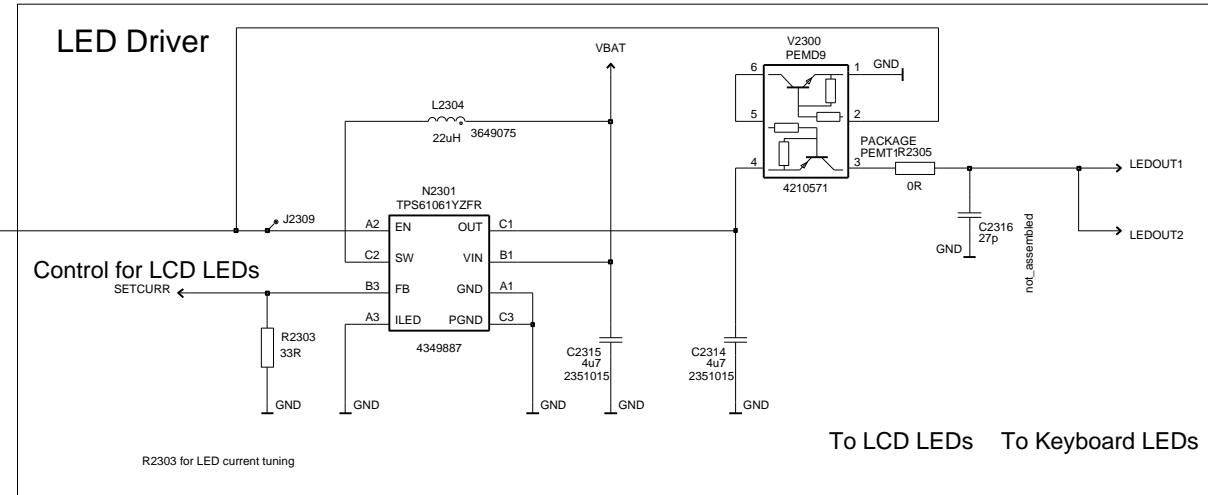
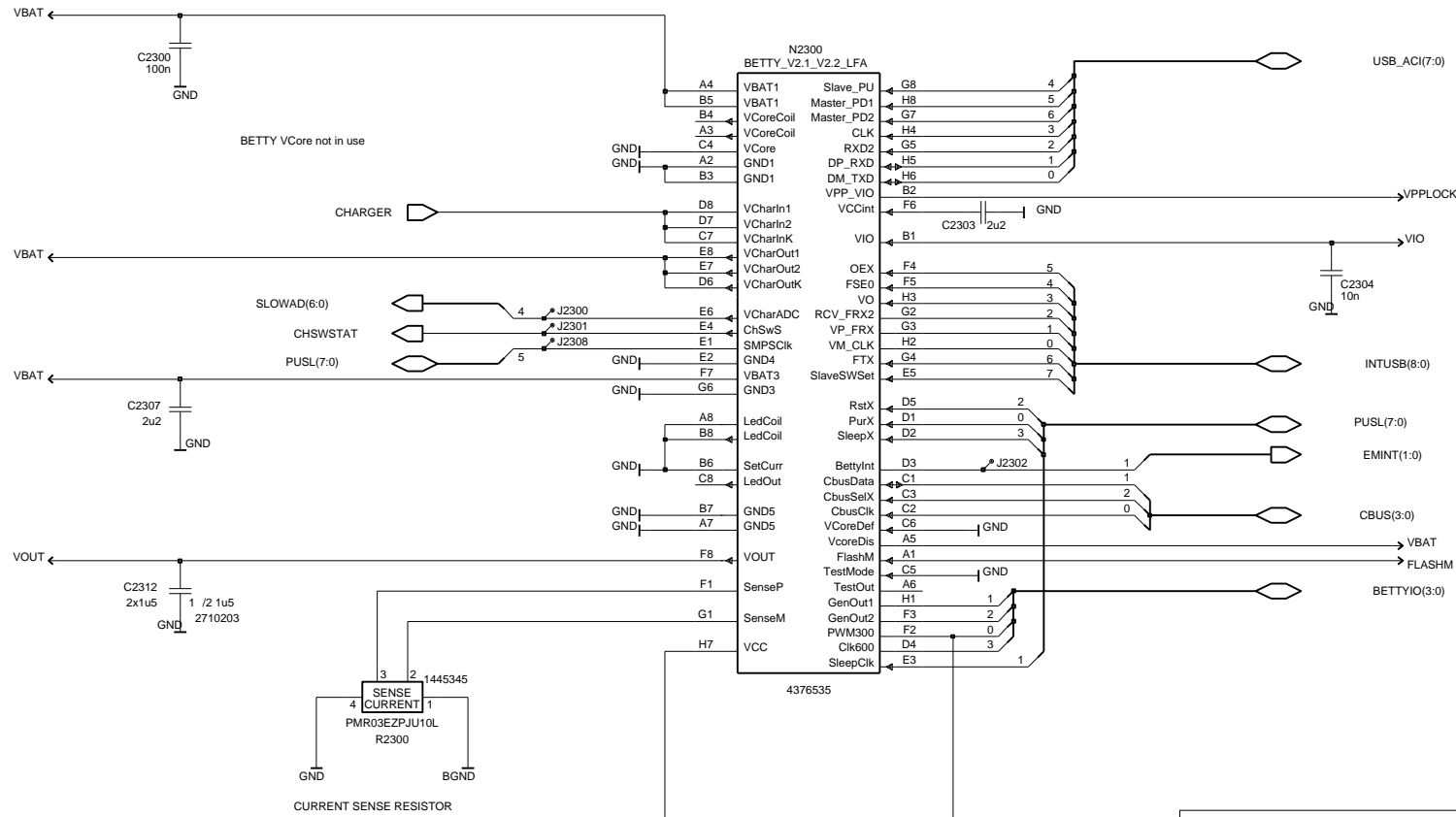

Copyright (C) Nokia Corporation. All rights reserved.
 THIS DRAWING IS PROTECTED BY COPYRIGHT AS AN UNPUBLISHED WORK.
 UNAUTHORIZED REPRODUCTION OF THIS DRAWING IS NOT PERMITTED.
 THIS DRAWING CONTAINS PROPRIETARY AND CONFIDENTIAL INFORMATION.
 This document is property of Nokia Corporation



Reference schematic

NOTE! SDA and SCL lines should include 10-47kOhm pull up resistors. Resistors value is dependent on number of I2C slaves

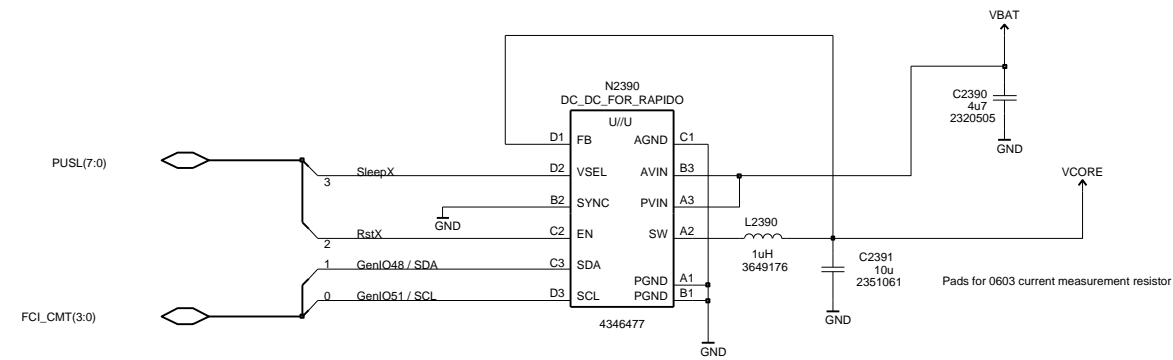

Copyright (C) Nokia Corporation. All rights reserved.
 THIS DRAWING IS PROTECTED BY COPYRIGHT AS AN UNPUBLISHED WORK.
 UNAUTHORIZED REPRODUCTION OF THIS DRAWING IS NOT PERMITTED.
 THIS DRAWING CONTAINS PROPRIETARY AND CONFIDENTIAL INFORMATION.
 This document is property of Nokia Corporation



Name
 Reference schematic

Appr
 dd-mmm-yy

CBB5X

TOP SHEET

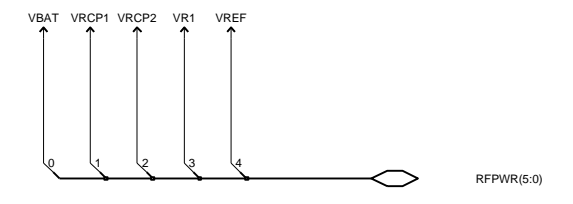
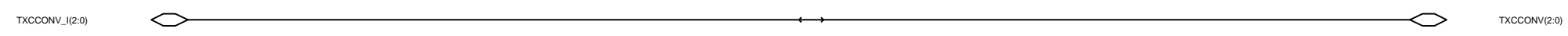
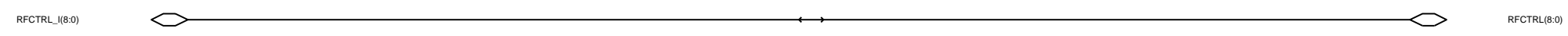
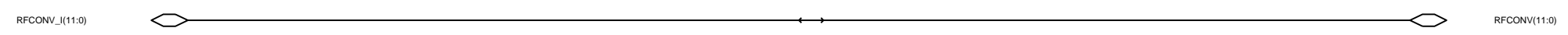
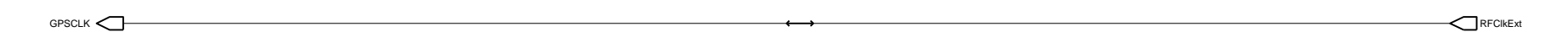
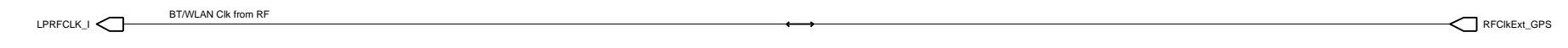
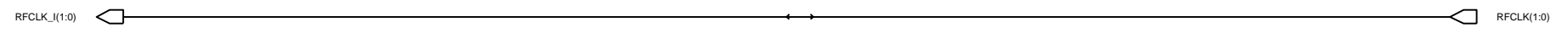

Copyright (C) Nokia Corporation. All rights reserved.
 THIS DRAWING IS PROTECTED BY COPYRIGHT AS AN UNPUBLISHED WORK.
 UNAUTHORIZED REPRODUCTION OF THIS DRAWING IS NOT PERMITTED.
 THIS DRAWING CONTAINS PROPRIETARY AND CONFIDENTIAL INFORMATION.
 This document is property of Nokia Corporation



Name RF IF

Appr dd-mmm-yy

