

CONFIDENTIAL

SERVICE MANUAL

Level 1&2

NOKIA 6270

RM-56



Transceiver characteristics:

BAND: Quad-band phone for GSM 850/900/1800/1900MHz

CAMERA: 2 Mega pixel camera with landscape camera mode and
Flashlight

DISPLAY: Active matrix color display with 262.144 colors,
resolution 320 x 240 pixel

BLUETOOTH

IRDA

FM RADIO

CARD TYPE: miniSD™

CONNECTOR: Pop Port connector

AUDIO: 2 IHF speaker for 3D-stereo sound effects

Transceiver with BL-5c 900mAh Li-Ion battery pack

Talk time	Standby	Note
up to 3-5h	up to 8days	Depends on network parameters

Environmental characteristics:

- Lead-free soldered

CONFIDENTIAL

TABLE OF CONTENTS

	Page
1. INTRODUCTION	3
2. GENERAL REPAIR INFORMATION	4
3. PATHFINDER FOR WORKSHOP STAFF	5
4. EXPLODED VIEW AND COMPONENT DISPOSAL	6
5. SPARE PARTS OVERVIEW	7
6. SPARE PARTS LIST	8
7. SERVICE TOOLS	9
8. SW-UPDATE	11
9. DISASSEMBLY INSTRUCTION (UPPER PART)	12
10. DISASSEMBLY INSTRUCTION (LOWER PART)	15
11. LEGEND FOR QUICK TROUBLE SHOOTER	20
12. QUICK TROUBLE SHOOTER PART 1	21
13. QUICK TROUBLE SHOOTER PART 2	22
14. QUICK TROUBLE SHOOTER PART 3	23
15. QUICK TROUBLE SHOOTER PART 4	24
16. CAMERA GONOGO TEST	25
17. BLUETOOTH & INFRARED TEST	26
18. GONOGO TEST	27
19. BATTERY TEST	27
20. FORWARDING OF REPAIRS	28
21. ESD PROTECTION REQUIREMENTS	29

CHANGE HISTORY

Status	Version No.	Date	Comments
Draft	0.1	09.11.2005	Initial draft
Approved	1.0	17.11.2005	Approval
Approved	2.0	25.11.2005	Quick Trouble Shooter added

1. INTRODUCTION

The purpose of this document is to help NOKIA service levels 1 and 2 workshop technicians to carry out service to NOKIA products. This Service Manual is to be used only by authorized NOKIA service suppliers, and the content of it is confidential. Please note that NOKIA provides also other guidance documents (e.g. Service Bulletins) for service suppliers, follow these regularly and comply with the given instructions.

While every endeavor has been made to ensure the accuracy of this document, some errors may exist. If you find any errors or if you have further suggestions, please notify NOKIA using the address below:

<mailto:cc-ts-rc.documentation@nokia.com>

Please keep in mind also that this documentation is continuously being updated and modified, so watch always out for the newest version.

Warnings and Cautions

Please refer to the phone's user guide for instructions relating to operation, care and maintenance including important safety information. Note also the following:

Warnings:

1. CARE MUST BE TAKEN ON INSTALLATION IN VEHICLES FITTED WITH ELECTRONIC ENGINE MANAGEMENT SYSTEMS AND ANTI-SKID BRAKING SYSTEMS. UNDER CERTAIN FAULT CONDITIONS, EMITTED RF ENERGY CAN AFFECT THEIR OPERATION. IF NECESSARY, CONSULT THE VEHICLE DEALER/MANUFACTURER TO DETERMINE
2. THE IMMUNITY OF VEHICLE ELECTRONIC SYSTEMS TO RF ENERGY.THE HANDPORTABLE TELEPHONE MUST NOT BE OPERATED IN AREAS LIKELY TO CONTAIN POTENTIALLY EXPLOSIVE ATMOSPHERES EG PETROL STATIONS (SERVICE STATIONS), BLASTING AREAS ETC.
3. OPERATION OF ANY RADIO TRANSMITTING EQUIPMENT, INCLUDING CELLULAR TELEPHONES, MAY INTERFERE WITH THE FUNCTIONALITY OF INADEQUATELY PROTECTED MEDICAL DEVICES. CONSULT A PHYSICIAN OR THE MANUFACTURER OF THE MEDICAL DEVICE IF YOU HAVE ANY QUESTIONS. OTHER ELECTRONIC EQUIPMENT MAY ALSO BE SUBJECT TO INTERFERENCE.

Cautions:

1. Servicing and alignment must be undertaken by qualified personnel only.
2. Ensure all work is carried out at an anti-static workstation and that an anti-static wrist strap is worn.
3. Use only approved components as specified in the parts list.
4. Ensure all components, modules screws and insulators are correctly re-fitted after servicing and alignment.
5. Ensure all cables and wires are repositioned correctly.



Electrostatic discharge can easily damage the sensitive components of electronic products. Therefore every Service Supplier has to take care of all precautions, which are mentioned in the service level related "Service Partner Requirements", available on NOKIA Online. Also see ESD Protection Requirements in this Service Manual.

2. GENERAL REPAIR INFORMATION

In this section the technician will get some general hints how to carry out repairs:

- To familiarize oneself with NOKIA product read the tutorials or user guide on www.nokia.com -->Support--> Phones, by selecting the Phone Model.
 - Before starting the repair you must take care of ESD precautions like being in your ESD Protected Area and connecting your wristband.
 - Use gloves to avoid corrosion and fingerprints.
 - Protect windows and displays with a film to avoid dust and scratches.
 - When cleaning the LCD Module any lint-free cloth can be used (e.g. Micro-Fibre cloth).
 - When cleaning the pads you have to use a soft cloth/ESD brush and Isopropanol. It is not allowed to use a glass fiber pencil because it scratches the surface and will lead later on to corrosion.
 - Mechanical parts (except shielding lids and bent parts), which didn't repair the failure, can be reused, if they are not soldered.
 - When removing the shielding lids make sure to replace them with new ones, otherwise the high-frequency leakage can have an influence on the device.
 - Always use original NOKIA spare parts.
 - Check the soldering joints of the parts, which are concerned regarding the indicated error (e.g. soldered connectors or switches) and resolder them if necessary (Level 2 only).
 - Remove redundant soldering flux after repair.
 - Meet the torque requirements when assembling the unit (see also the document "torques for transceiver assembly" on NOKIA Partner Web Site/NOKIA Online).
 - Always use your own equipment for testing where you are sure that it works. E.g. if the customer complains about charger function, please test the phone with your own charger to be sure if phone or charger causes the malfunction.
 - A SIM card is needed for all GoNoGo tests.
 - When doing the fault log entries, always note the Item code, which caused the malfunction. Also, fill in the appropriate part code from the assembly, if needed.
 - Please be aware that some malfunctions could be software related and solved by an update.
-
- There are several documents available on NOL, which have to be followed:
 -
 - First, take care for the latest content pages of Service Bulletins, which are always available for each folder on NOKIA Online. This is also important to recognize, if existing documents have become invalid.
 -
 - The service level indicator at the bottom of each document tells the appropriate destination.

Downloads > Support Library >

1. Instructions
 2. General Service Bulletins
 3. Product related documents
 4. Spare Part Service Bulletins
 5. Service Tools Service Bulletins
 6. Common Software Service Bulletins
- etc,...

Use General SB-217 as a reference or overview.

Please also check NOKIA Online (NOL) for latest news and files on a regular basis.

3. PATHFINDER FOR WORKSHOP STAFF

In addition to the information in this Service Manual, there are several instructions and information, which have to be followed. Main documentation database is [NOKIA Online](#) with the purpose of serving different multimedia content, like video clips or interactive tutorials.

It is mandatory to watch for newest technical and organizational information on a daily basis to be updated as required (see "Latest files in Support Library"). Every new information has to be processed and implemented as soon as possible. When logged into NOL you can also find needed information in different folder like:

Support Library

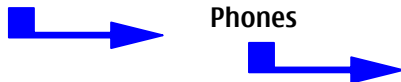

- Service Manuals
- Service Bulletins
- Software
- Repair Information

Level 1&2 e-learning (former NOKIA CarePoint) on NOKIA Online

Former NOKIA CarePoint content, such as	<ul style="list-style-type: none"> • Online Troubleshooting • Product information • Videos – Disassembly/Assembly 	can be found on NOKIA Online
		<p style="text-align: center;">NOKIA Online</p> <p style="text-align: center;">↓</p> <p style="text-align: center;">Care Services</p> <p style="text-align: center;">↓</p> <p style="text-align: center;">Training</p> <p style="text-align: center;">↓</p> <p style="text-align: center;">Phone Models</p>

Level 1&2 e-learning courses offer a quick overview of the NOKIA phone and support for how to repair and use the phone:

Overview & Guides Basic information about the phone, features and technologies	Disassembly & Assembly Instructions how to disassemble and assemble the phone	Troubleshooting Step-by-step instructions on how to locate and repair the most common problems with the phone
--	---	---

To reduce the server traffic it is recommended to download newest version of huge files like videos, Phoenix packages or Service Manuals only once and distribute it internally for further use.

4. EXPLODED VIEW AND COMPONENT DISPOSAL

Recommendation for the ecologically friendly disposal of components. Colorized components show the different categories. See corresponding ITEM/CIRCUIT REF in the Spare Parts Service Bulletins on NOL.

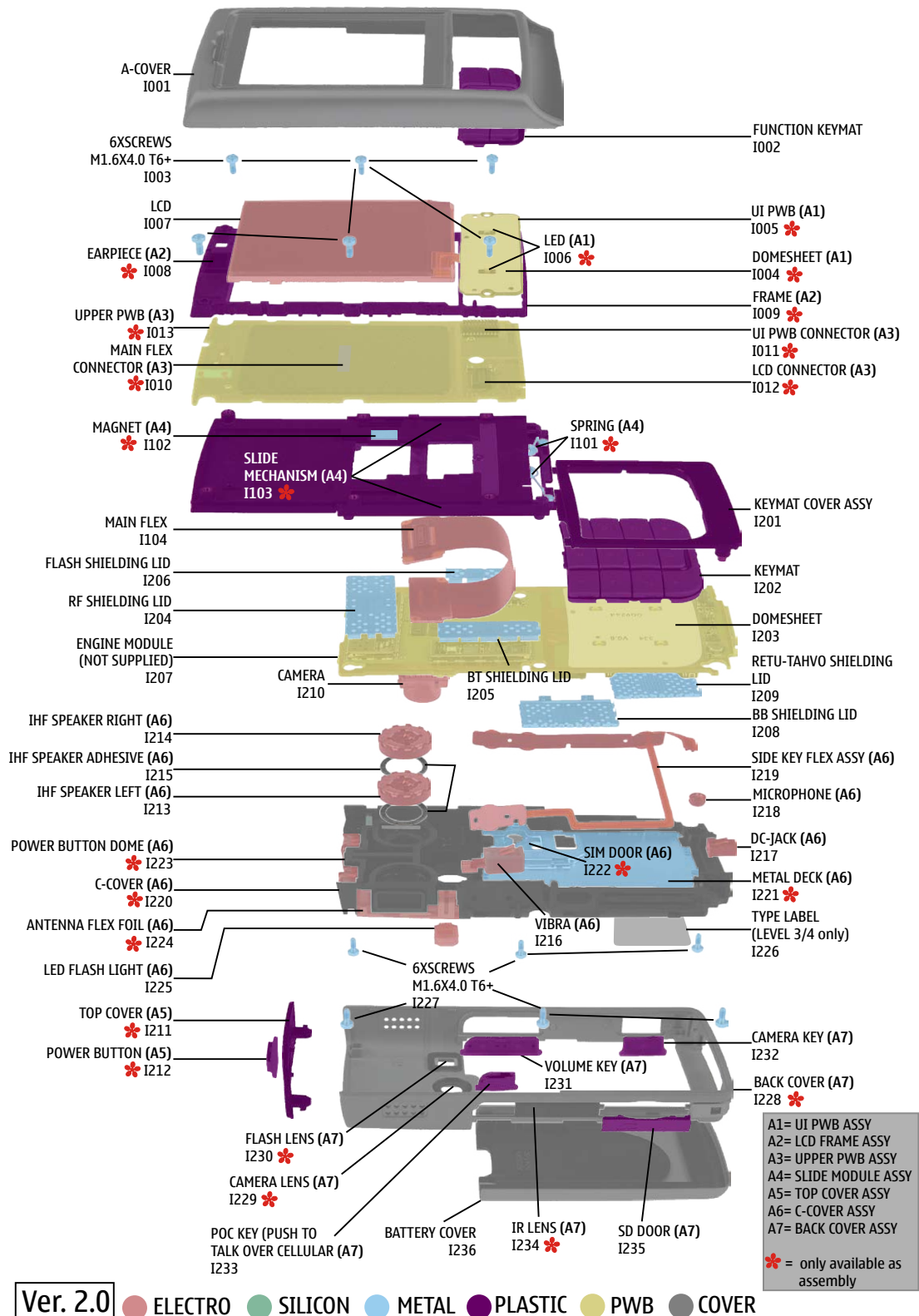

5. SPARE PARTS OVERVIEW

A2 = LCD FRAME ASSY

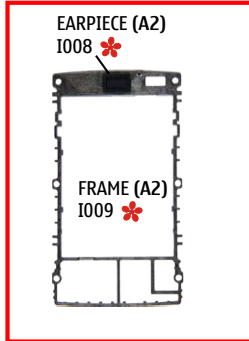

A3 = UPPER PWB ASSY

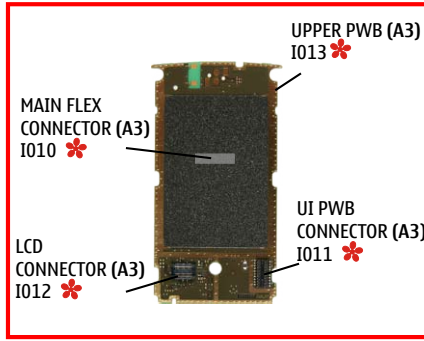

A4 = SLIDE MODULE ASSY

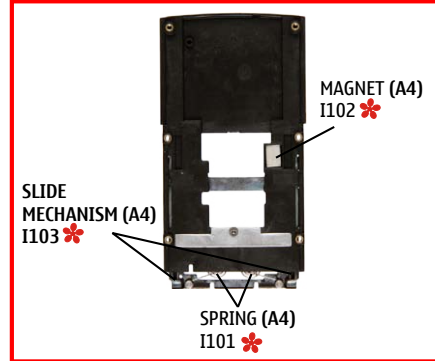

A1 = UI PWB ASSY

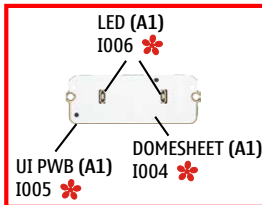

A5 = TOP COVER ASSY



A7 = BACK COVER ASSY

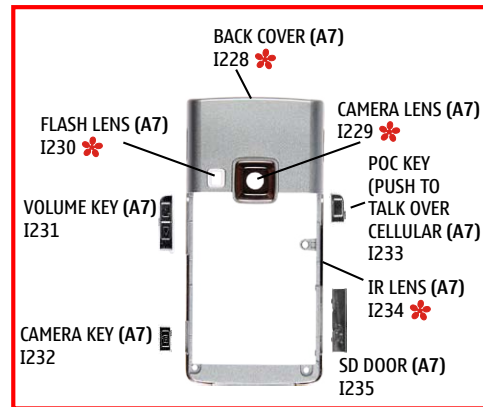

A6 = C-COVER ASSY

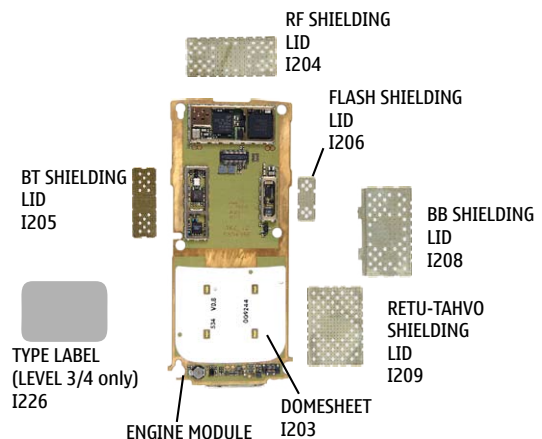
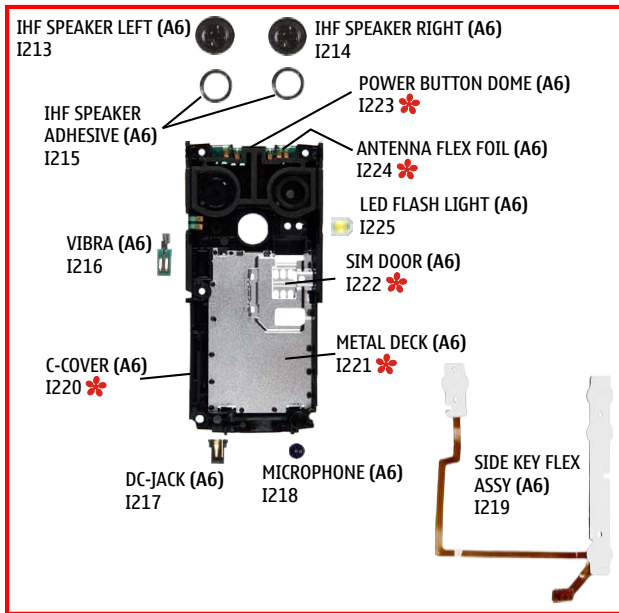

A-COVER
I001



KEYMAT
I202
KEYMAT COVER ASSY
I201



FUNCTION KEYMAT
I002



LCD
I007



MAIN FLEX
I104



6XSCREWS
M1.6X4.0 T6+
I003



CAMERA
I210



6XSCREWS
M1.6X4.0 T6+
I227



BATTERY COVER
I236

A1= UI PWB ASSY
 A2= LCD FRAME ASSY
 A3= UPPER PWB ASSY
 A4= SLIDE MODULE ASSY
 A5= TOP COVER ASSY
 A6= C-COVER ASSY
 A7= BACK COVER ASSY
 * = only available as assembly

Ver. 2.0

6. SPARE PARTS LIST

Please exchange this page (placeholder) with latest corresponding Service Bulletins (spare parts, SWAP units and service tools) from NOL!

This will ensure, that you are using up-to-date order codes only.

Therefore Service Bulletins have to be checked from NOL on daily basis.

[Home](#) | [User](#) | [Sitemap](#) | [Log Out](#)



Nokia Online

Search

[Care Services](#)

[Support Library](#) | [Warranty Info](#) | [Service Points](#) | [Training](#)

Support Library

Latest files
⇒ Browse files

Browse files

Select category:

Select subcategory:

Select subcategory:

Date range from: / /

until: / /

Search

Files for Service level 2 Date:03.02.2005







- XXXXXXXXXXXXXXXXXXXX

Files for Service level 1 Date:16.02.2005

- XXXXXXXXXXXXXXXXXXXX
- XXXXXXXXXXXXXXXXXXXX
- XXXXXXXXXXXXXXXXXXXX

© Nokia 2005 [legal notice and site usage terms](#) | [privacy policy](#).

7. SERVICE TOOLS

	<p>FLS-4S incl. ACF-8, Driver and User Guide Dongle and flash device incorporated into one package, developed specifically for POS use.</p>
	<p>ACF-8 Universal Power Supply is used to power FLS-4S.</p>
	<p>Travel Charger ACP-12 Small and lightweight charger for fast charging of your phone battery.</p>
	<p>Internal Battery BL-5C Inserted under the back cover, this Li-Ion 900 mAh battery provides power in a lightweight package.</p>
	<p>Headset HS-23 Small and lightweight stereo headset with handsfree functionality, volume control, Push to talk support, and comfortable earpieces for listening to the FM radio or MP3 player in compatible phones.</p>
	<p>SS-15 Camera removal tool. One side is for disassembly, the other side for assembly.</p>
	<p>RJ-76 Soldering Jig</p>

	<p>Lead-free Solder Wire Mandatory for lead-free products (Level 2 only).</p>
	<p>0772040 NMP Standard Toolkit</p> <ul style="list-style-type: none"> • NOKIA opening tool SRT-6 NOKIA No. 0770431 • Tonichi torque driver NOKIA No. 6901525 • Hoya micro Fibre cloth MX304 • Dastex gloves S, M, XL • Artlux goggles AH166 • Wera bit T5 867/4TX 5x50 • Wera 867/4 6IP; 50mm (Torx 6 PLUS®) • Wera bit T6 867/4TX 6x50 • Wera 867/1 5IP; 25mm (Torx 5 PLUS®) • Wera bit T6 PLUS® 867/4TX 6IP • Facom side cutter 416E • Facom T5 driver SP.14032 • Facom T6 driver SP.14033 • Facom slot screwdriver AEF. 2x35.E • Wetec tweezers 7abb SA-ESD • Wetec tweezers 22 SA-ESD • Wetec tweezers 13 SA-SMD ESD • Wetec tweezers PSF SA-ESD • Wetec ESD brush E1211 • Kaiser Fototechnik airbrush 6315 • Wetec dental tool DEM83266/0 • RS Components Scissors 323-5732

8. SW-UPDATE

Flash Concept – (Point of Sales)

To use FLS-4S Flash Dongle you have to follow the user guide inside the sales package. Please check always for the latest version of flash software, which is available on [NOKIA Online](#).

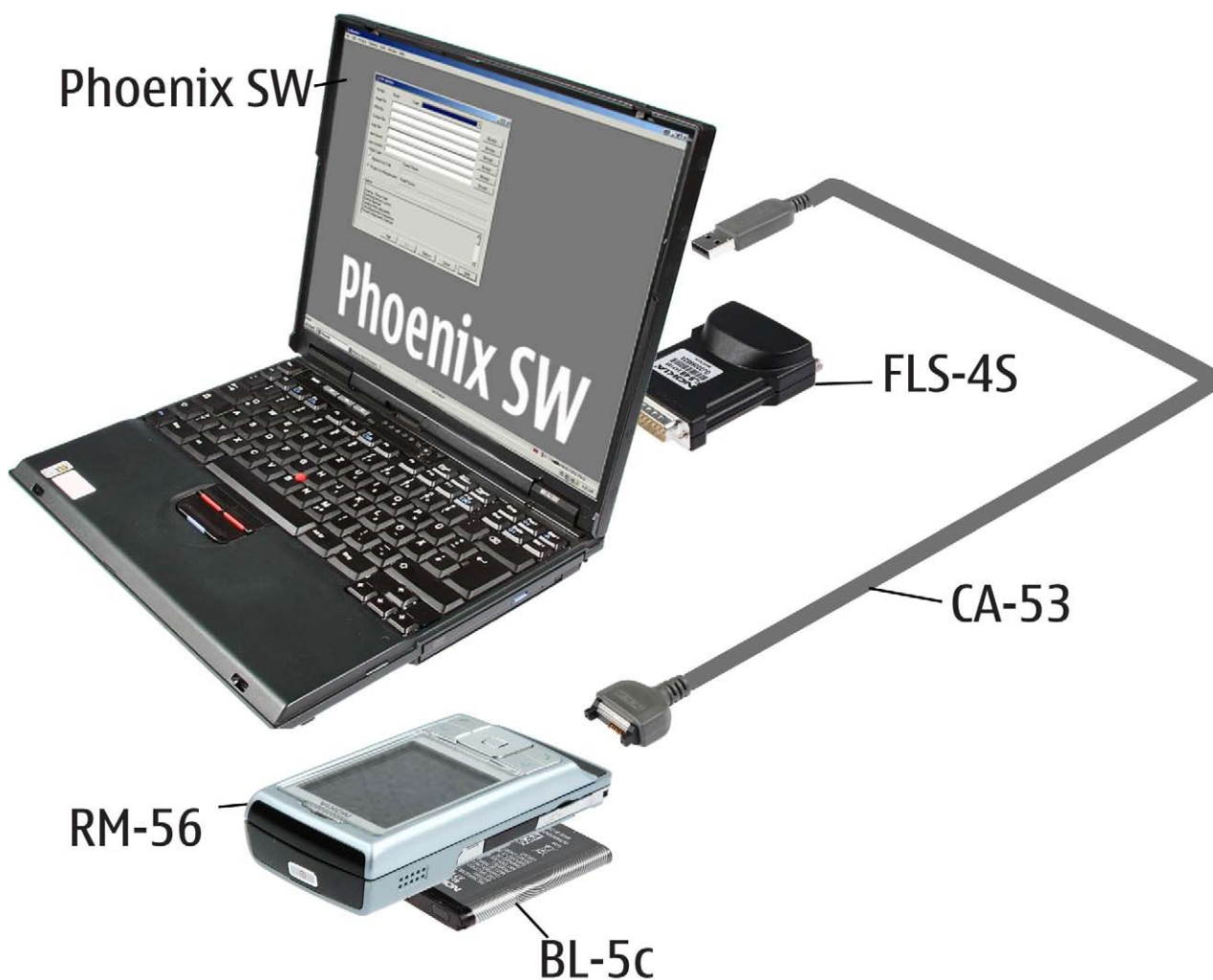

9. DISASSEMBLY INSTRUCTION (UPPER PART)

 <p>1. Needed tools for disassembly and assembly.</p>	 <p>2. Protect the window with a plastic film.</p>
 <p>3. Protect the camera window with a plastic film.</p>	 <p>4. Remove the Battery Cover. Ensure that no battery is still inserted.</p>
 <p>5. Carefully release the shown plastic clips from the bottom side.</p>	 <p>6. Prevent scratching the surfaces. Do not shift the SRT-6 along the sides.</p>
 <p>7. Continue on the opposite side.</p>	 <p>8. After releasing both clips shift out the unit.</p>



9. Now lift the lower side and hold it in this position.



10. Carefully release the upper clips of the A-Cover with a slotted screwdriver.



11. Release the clips on the opposite side, too.

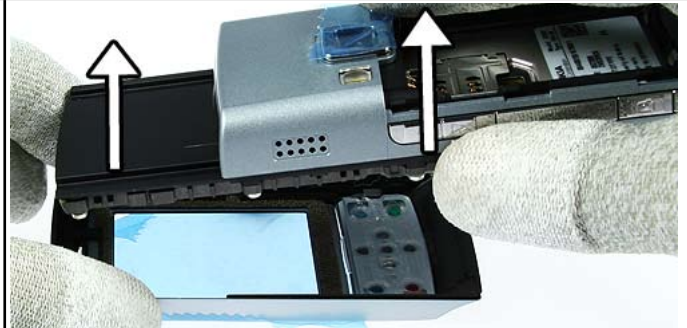

12. The separation of the parts becomes easy if all clips are released correctly.



13. Protect the inner side of the window with a plastic film and separate the Function Keymat.



14. Protect the LCD with a plastic film, too.



15. Remove 2 Torx Plus® size 6 screws in the order shown. **For assembly, use the reverse order and a torque of 14 Ncm.**

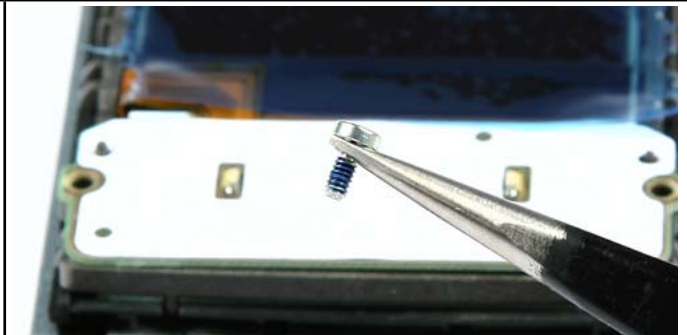

16. All screws in this phone must be renewed after removal.



17. Remove the UI PWB.

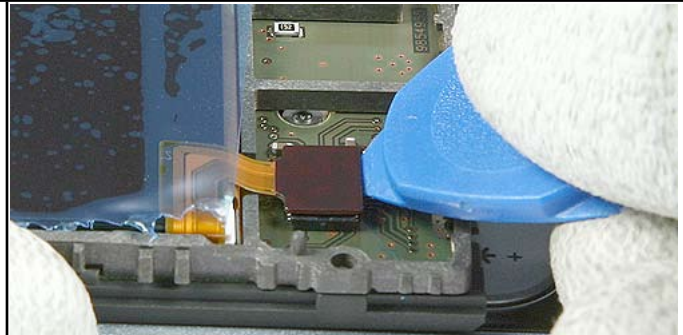

18. Open the flex connector.

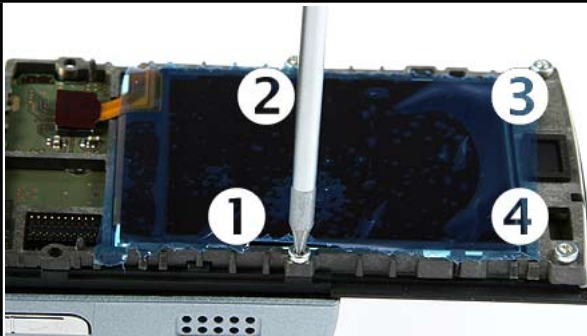

19. Remove 4 Torx Plus® size 6 screws in the shown order.
For assembly use the reverse order and the torque of 14 Ncm.



20. Remove the LCD Frame Assy.



21. Separate the LCD from the Frame.

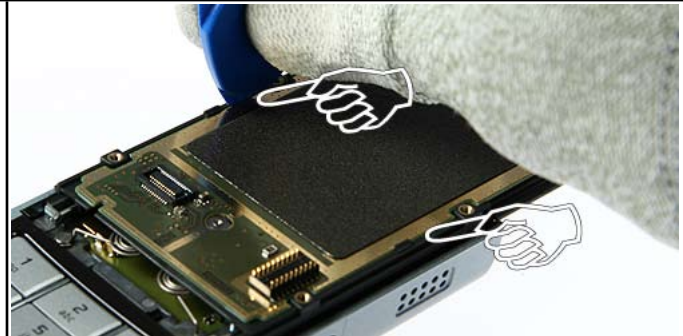

22. Release the clips and lift out the Upper PWB Assy. Bear in mind that the PWB is still connected with a flex foil.

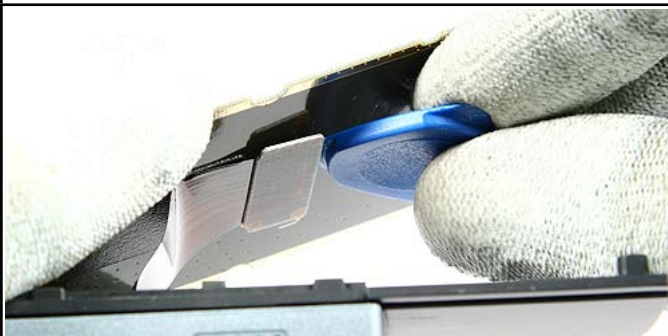

23. Carefully open the Main Flex Connector.



24. Remove the Upper PWB.

10. DISASSEMBLY INSTRUCTION (LOWER PART)



1. Needed tools for disassembly and assembly.



2. Protect the window with a plastic film.



3. Protect the camera window, too.



4. Remove the Battery Cover. Ensure that no battery is inserted.



5. Release the clips of the Keymat with the SRT-6 as shown.



6. Ensure that all clips are released.



7. Separate the Keypad.



8. Remove the 2 Torx Plus® size 6 screws in the order shown. **For assembly use the reverse order and a torque of 14 Ncm.**



9. Note that all screws used in this phone must be renewed after removal.



10. Release the plastic clips of the Keymat Cover Assy.



11. After releasing the clips, the Keymat Cover Assy can be removed easily.



12. Remove the screw. **For assembly use a torque of 14 Ncm.**



13. Release the clips of the Back Cover Assy on both sides as shown.



14. Carefully lift the Back Cover Assy from one side first. Place the connector side first when reassemble.



15. The keys are not fixed any more. Do not loose them.



16. Carefully push out the hinge from the SD Door at the shown side first.



17. Now pull out the other side.



18. Release the Flash Light with the SRT-6.

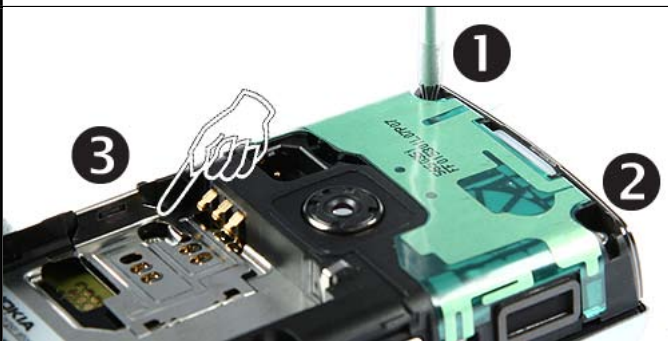

19. Remove the 3 screws in the order shown. **For assembly use the reverse order and a torque of 14 Ncm.**



20. Remove the Top Cover Assy.



21. Push out the Power Button.

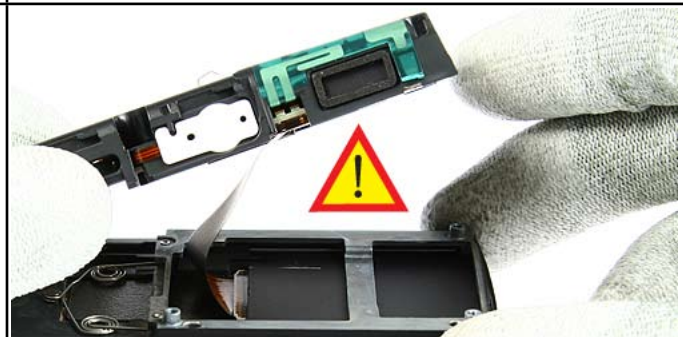

22. Lift out the Engine Module. Bear in mind that the Main Flex is still connected.

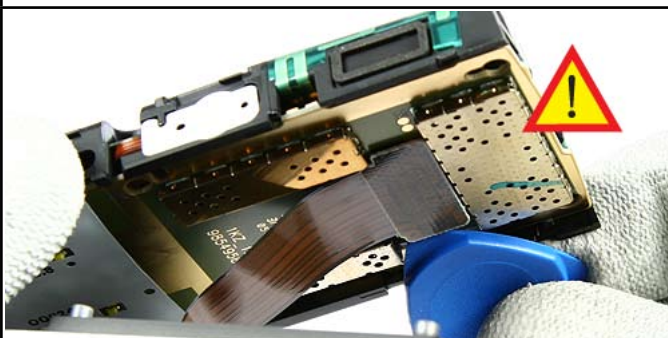

23. Open the connector of the Main Flex.

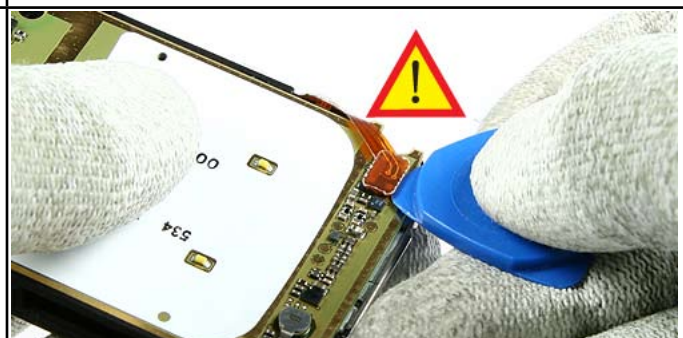

24. Open the connector of the Side Key Flex Assy.

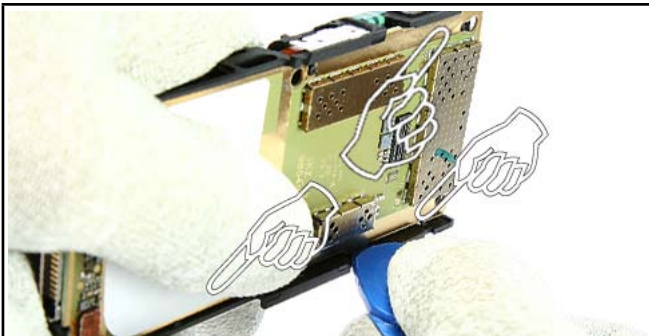

25. Release the plastic clips as shown.

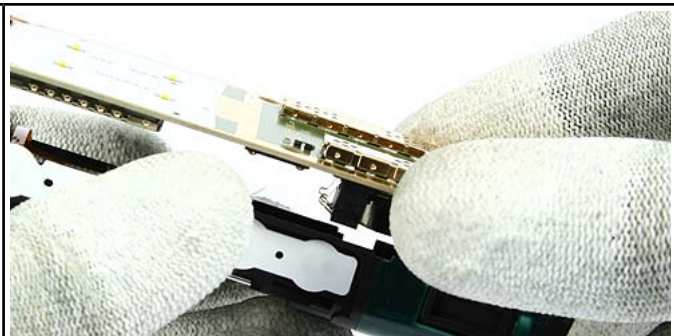

26. Lift out the Engine Module and place it into the rework jig.

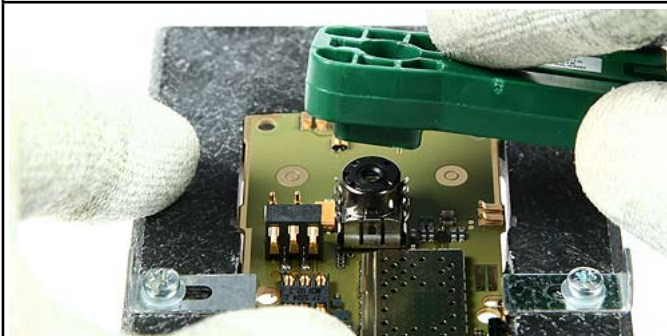

27. Use the SS-15 camera removal tool to remove the Camera.



28. Place the tool and push it down carefully. Fix the Camera.

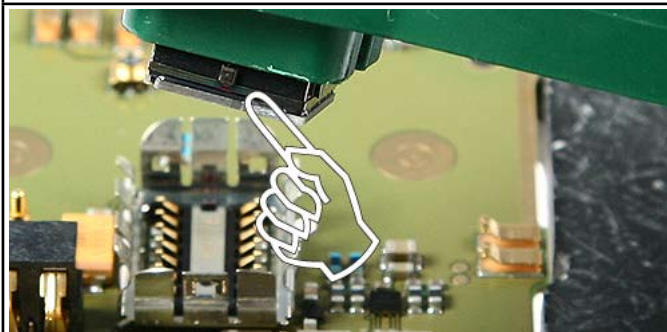

29. Now pull the Camera upwards. **For assembly mind the correct position and use the assembly side of the SS-15.**

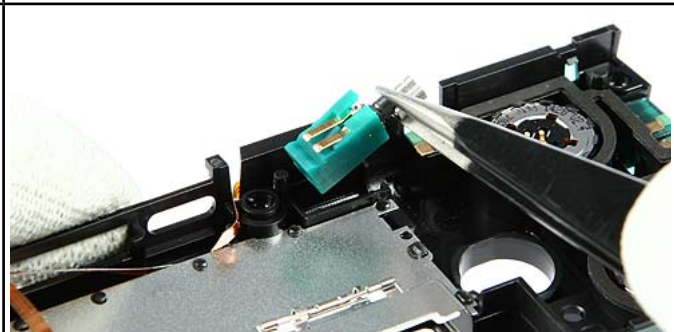

30. Lever out the Vibra.



31. Remove the DC-Jack with the DC plug.



32. Remove the Microphone with the dental tool.



33. Lever out both IHF Speakers.



34. The IHF Speaker Adhesives will be destroyed.



35. Peel up the Adhesive residues with tweezers. **Always use new ones when reassemble.**

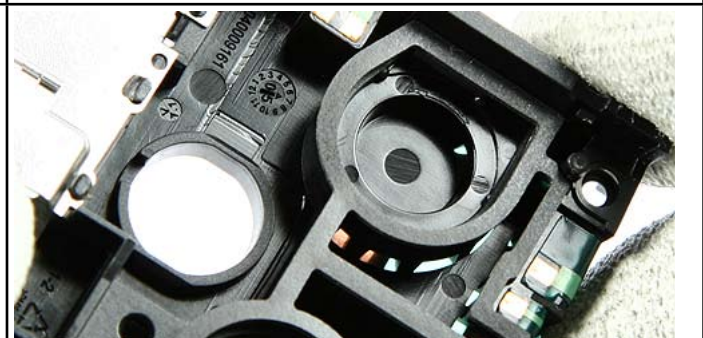

36. Ensure that no residues remain when replacing the IHF Speakers.



37. Peel up the Side Key Flex Assy with angled tweezers at the shown side first.

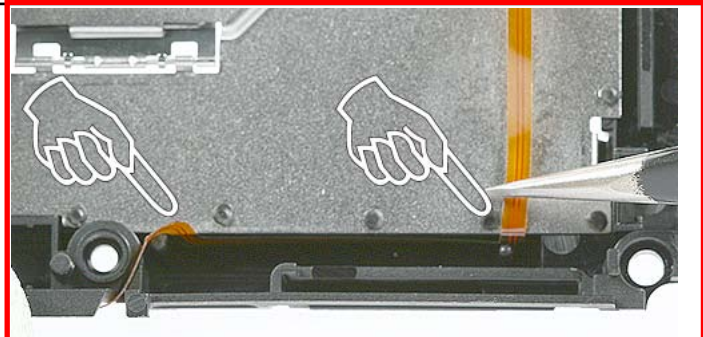

38. For Assembly note the 2 guide pins while placing a new Side Key Flex Assy.

















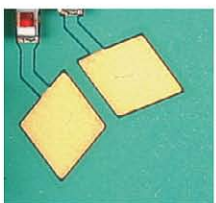

39. Continue with the larger part. Peel it up slowly to prevent adhesive residues.

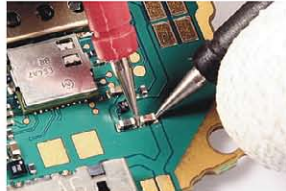

40. For Assembly mind the correct positioning of the Side Key Flex Assy.

11.LEGEND FOR QUICK TROUBLE SHOOTER

Legend for Quick Troubleshooter	
This legend is valid for all parts of the Quick Troubleshooter	
Follow the steps until the problem is solved. If this doesn't help, you are not authorized to go forward.	
	The start point of repair activities regarding the appeared fault symptoms.
	Only marked components (e.g. I002 ) can be replaced.
	<p>Cloth usage: Check pads or contacts for optical and mechanical condition particularly regarding to corrosion. Clean it if necessary.</p>    
	<p>Measure component for electrical functionality and change, if needed. (Level 2 only)</p>  
	<p>ESD Brush usage: Check pads or contacts for optical and mechanical condition particularly regarding to corrosion. Clean it if necessary.</p>    
	No more action possible - send product to the appropriate service supplier with higher service level.

12. QUICK TROUBLE SHOOTER PART 1

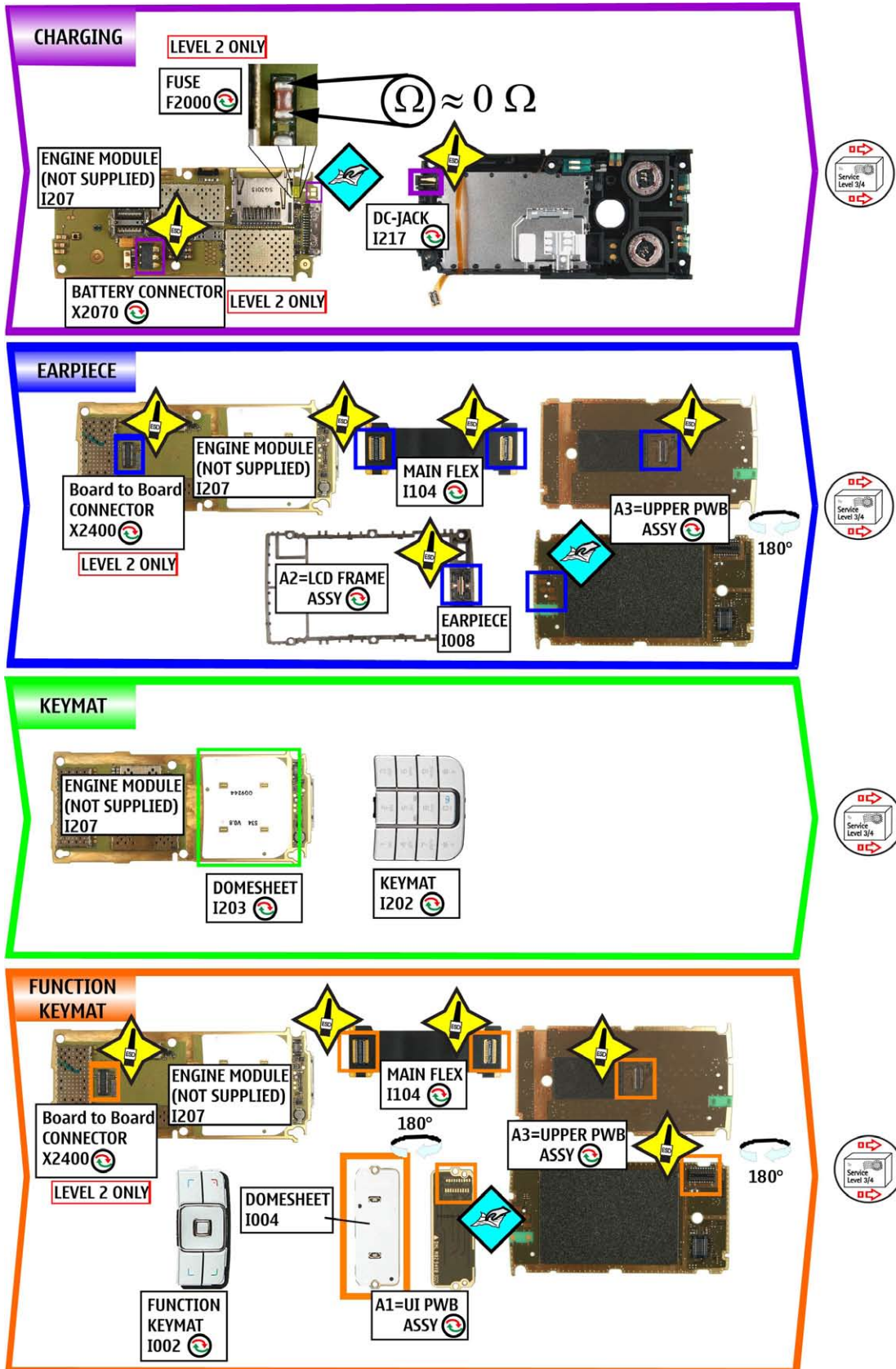

13. QUICK TROUBLE SHOOTER PART 2

IHF SPEAKER

ENGINE MODULE (NOT SUPPLIED) I207

IHF SPEAKER LEFT I213

A6=C-COVER ASSY

IHF SPEAKER RIGHT I214

SERVICE GSM

ENGINE MODULE (NOT SUPPLIED) I207

SPRING CONTACTS LEVEL 2 ONLY

X7550

X7551

X7555

A6=C-COVER ASSY

ANTENNA FLEX FOIL I224

DISPLAY

ENGINE MODULE (NOT SUPPLIED) I207

Board to Board CONNECTOR X2400

MAIN FLEX I104

LCD I007

A3=UPPER PWB ASSY

180°

BLUETOOTH

ENGINE MODULE (NOT SUPPLIED) I207

BT ANTENNA CONTACTS

A6=C-COVER ASSY

SPRING CONTACTS LEVEL 2 ONLY

X6002

X6001

14. QUICK TROUBLE SHOOTER PART 3

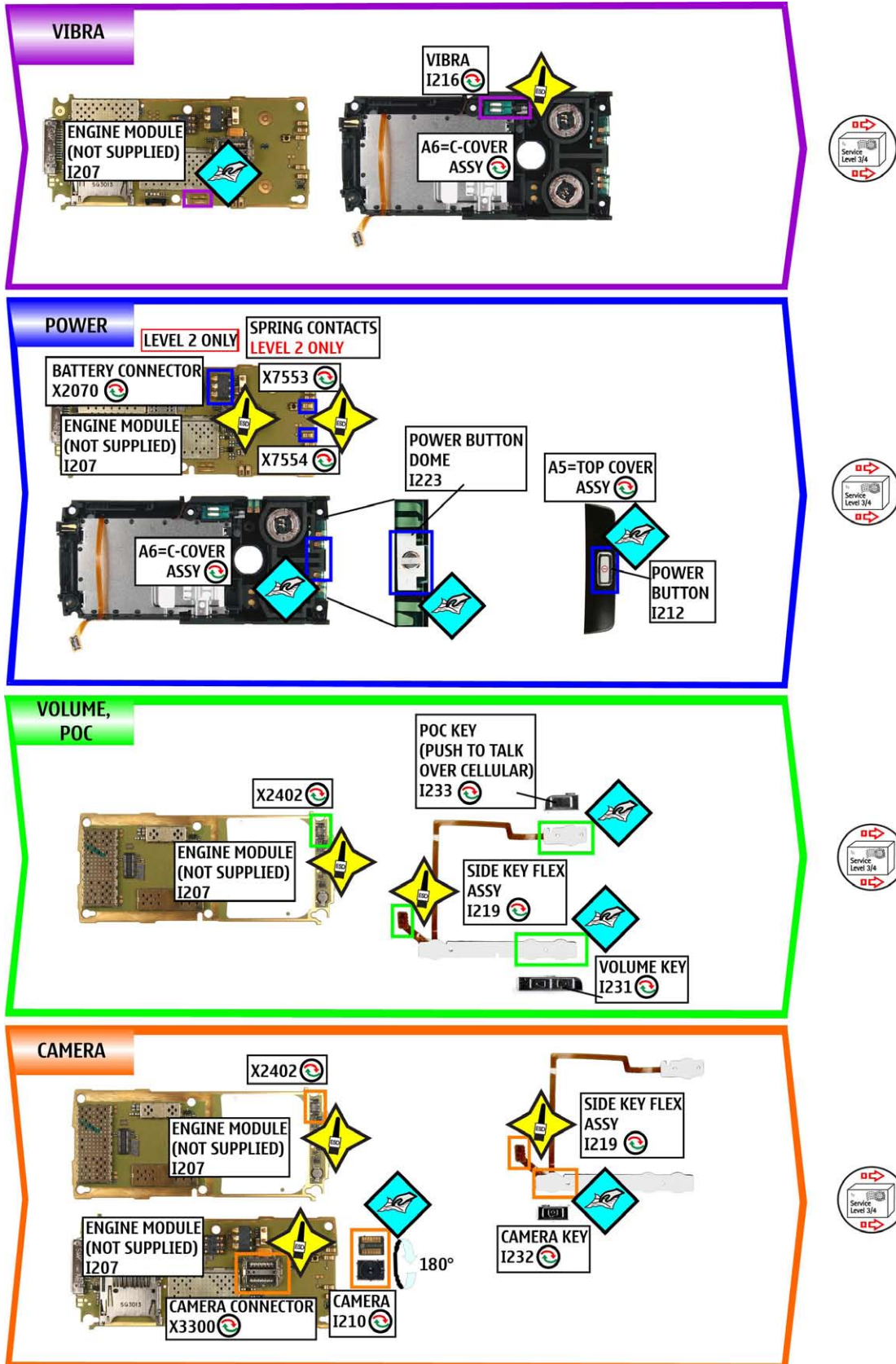

15. QUICK TROUBLE SHOOTER PART 4

LED FLASH LIGHT

SD

MICROPHONE

SIM



16. CAMERA GONOGO TEST

Before starting the GoNoGo test, check that camera window is clean. If not, clean the window with cloth.



- Press the red End button  to reach the Home Menu

- Select Menu 
- Select Media
- Select Camera

- Press Capture  or use the Camera Key  to take a photo
This Image will be saved to Gallery into the Photos folder automatically.
Test was successful, if the Image appears on your Display. The camera is ok.
- Select Delete
- Select Yes
- Press the red End button to reach the Home Menu

If the test is failed see Quick Trouble Shooter.

17. BLUETOOTH & INFRARED TEST

Bluetooth test

You need another Bluetooth device (e.g. 6230) to do a GoNoGo test.

Make sure that Bluetooth is activated in the reference unit. The distance of the devices should be not more than 5m from each other.

Infrared test

You need another infrared device (e.g. 6230) to do a GoNoGo test. The infrared windows of the devices must be directed to each other and should have a distance of approximate 15 cm. Make sure that infrared is activated in receiver device.

Warning: Do not point the IR (infrared) beam at anyone's eye or allow it to interfere with other IR devices. This device is a Class 1 Laser product.

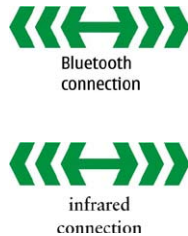

Reference unit, Bluetooth /infrared activated

Test unit

Settings on the test unit:

- Press the red End key  to reach the Home Menu
- Select Names
If phone and SIM memory is empty, create one new entry.
- Select an entry and select Details
- Select Options
- Select Send business card

A) - for infrared test: Select Via infrared

If sending of business card fails, make sure again that infrared windows are directed to each other and infrared is activated in reference unit. Then try again sending.

Test was successful, if you get the message "Business card received" on the Reference unit.

You will not get a confirmation on sender device.

B) - for Bluetooth test: Select Via Bluetooth

Search window appears and shows all Bluetooth units in range.

Choose one unit and press Select

Press Accept on the Reference unit.

Test was successful, if you get the message "Business card received" on the Reference unit.

- Press red End key of the Test unit to reach the Home Menu

Note: If the Bluetooth is activated, switch it off!

18. GONOGO TEST

After the optical check, a GoNoGo test has to be carried out if the unit has been unscrewed to guarantee the functionality of the phone.

Please refer to the actual information on NOKIA Online. When using delivered tester support files, take care of the right setup according to the tester type and product type.

Please refer to "Recommended Service Equipment" on NOKIA Online.

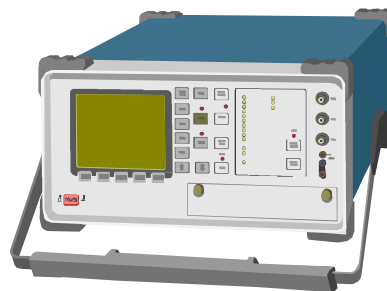

Mobile Phone Tester

19. BATTERY TEST

A battery tester lets you test the capacity of NOKIA batteries.

Please refer to the actual information on NOKIA Online.



<http://www.astratec.co.uk/>



<http://www.cadex.com/>

20. FORWARDING OF REPAIRS

When it is necessary to forward of repairs to appropriate service supplier with higher service level we recommend using the offered swap phone cartons as described in Spare Parts SB-004.

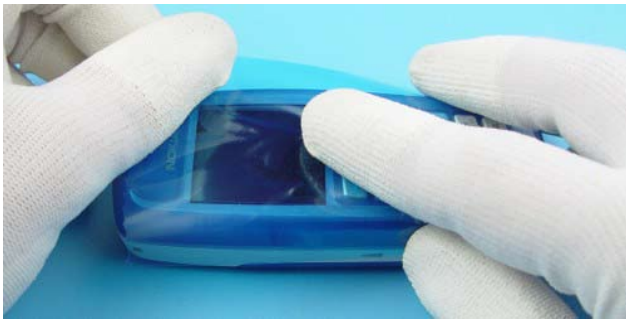

Always Protect the window with a protection film.



Put the unit under the stretch film.



Add repair documentation e.g. filled-in service note into the swap carton.



Fold the swap carton as shown in Spare Parts SB-004.



There are two different sizes of swap cartons for common mobile phones.

21.ESD PROTECTION REQUIREMENTS

Please refer to the NOKIA Online document [Service Supplier Requirements](#) in folder General instructions.

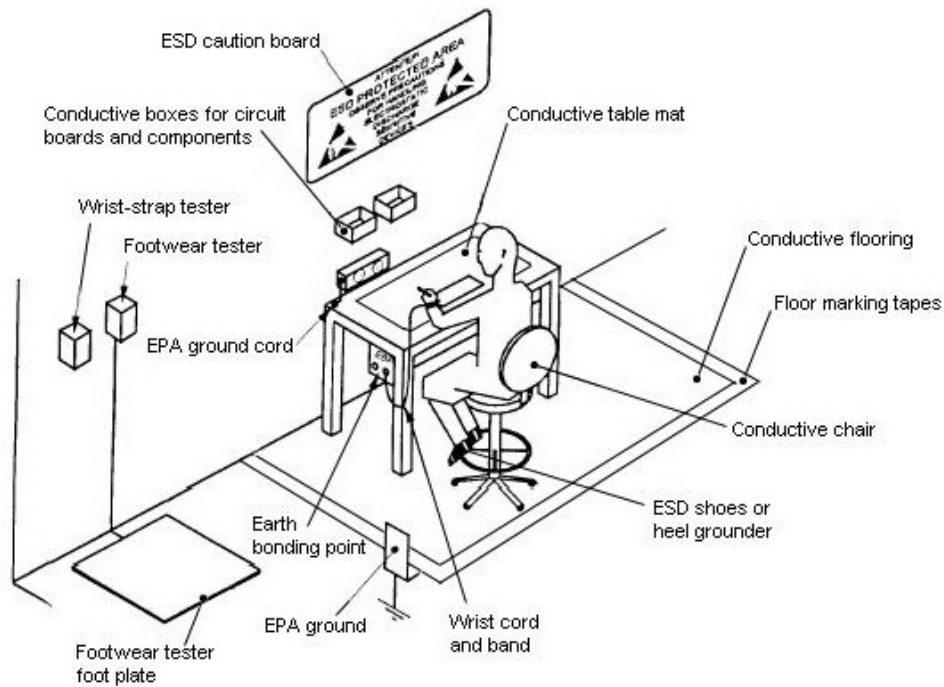

- USE** Conductive bags and boxes
- USE** ESD compatible service tools
- USE** Conductive wastebaskets
- USE** ESD gloves when handling PWBs/PCBs
- USE** Cleaning material without changing el. Characteristics
- USE** Grounded service equipment, i.e. soldering station
- USE** ESD clothes such as coat or frock

- NO** Smoking
- NO** Drinking
- NO** Eating
- NO** Dust
- NO** Useless Items
- NO** Normal pressured air for cleaning modules/ displays



The video covers general issues concerning Electro-Static Discharge (ESD)