

9-1.Baseband

9-1-1. Power ON

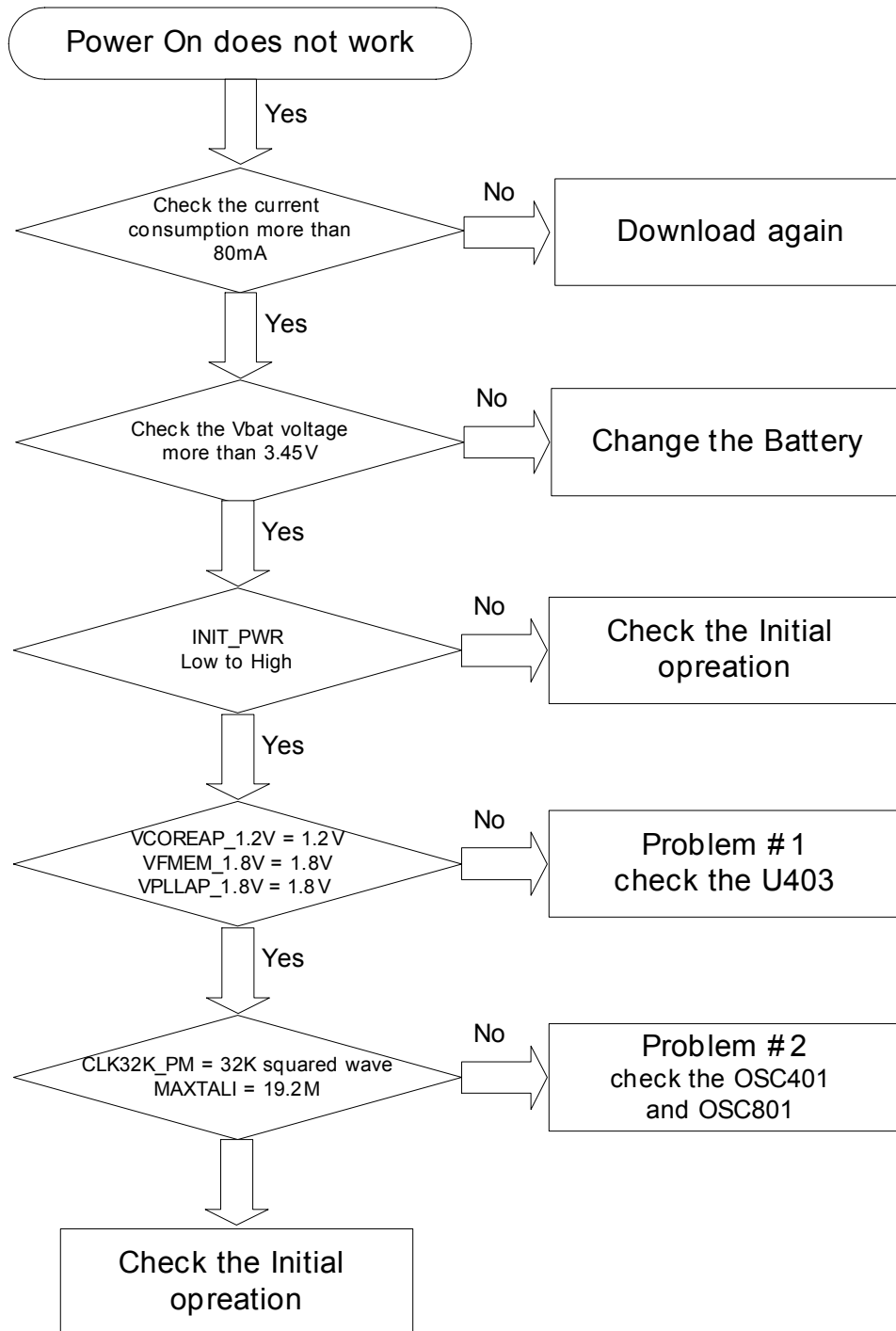

Power On Problem #1

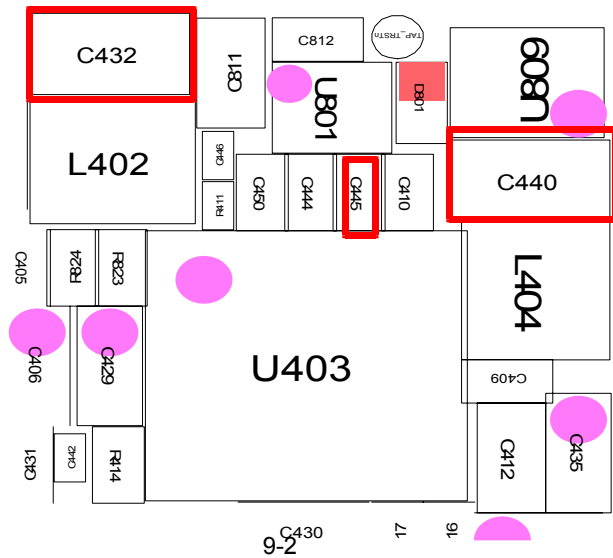
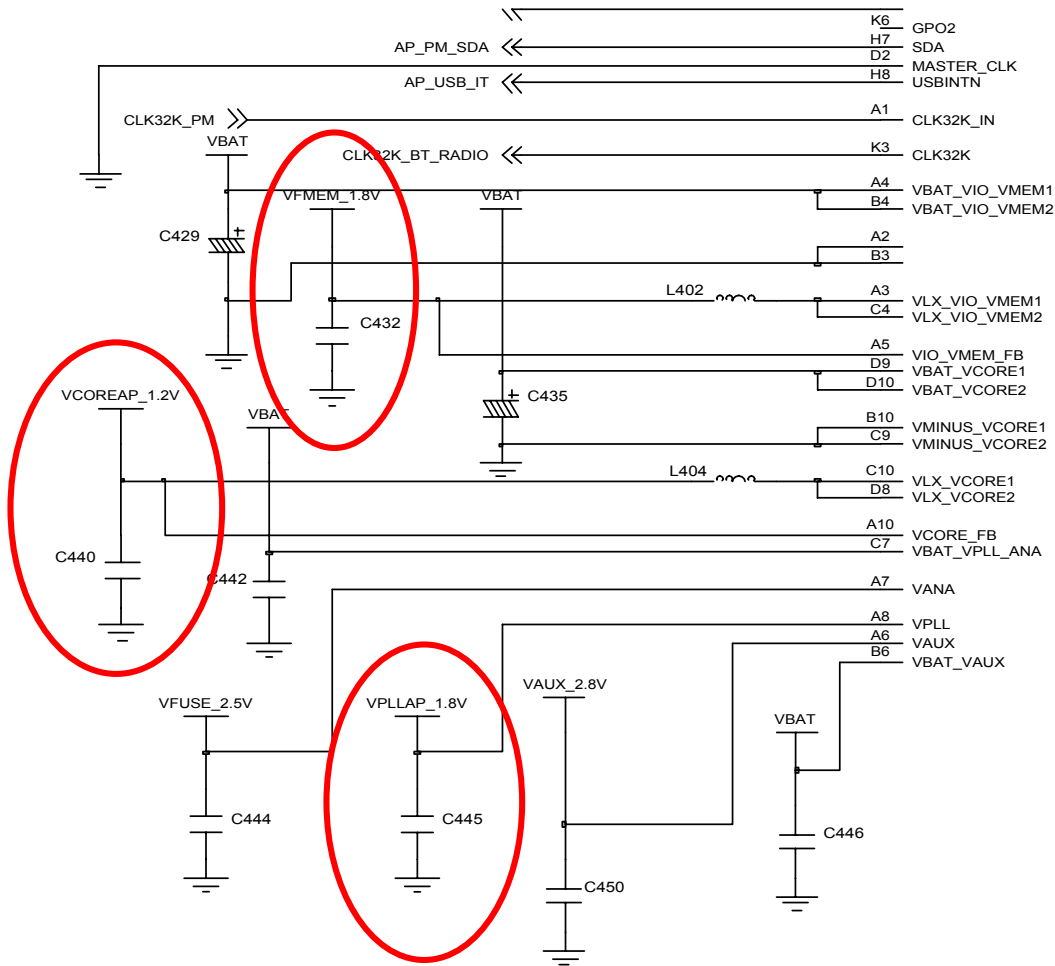

Power On Problem #2

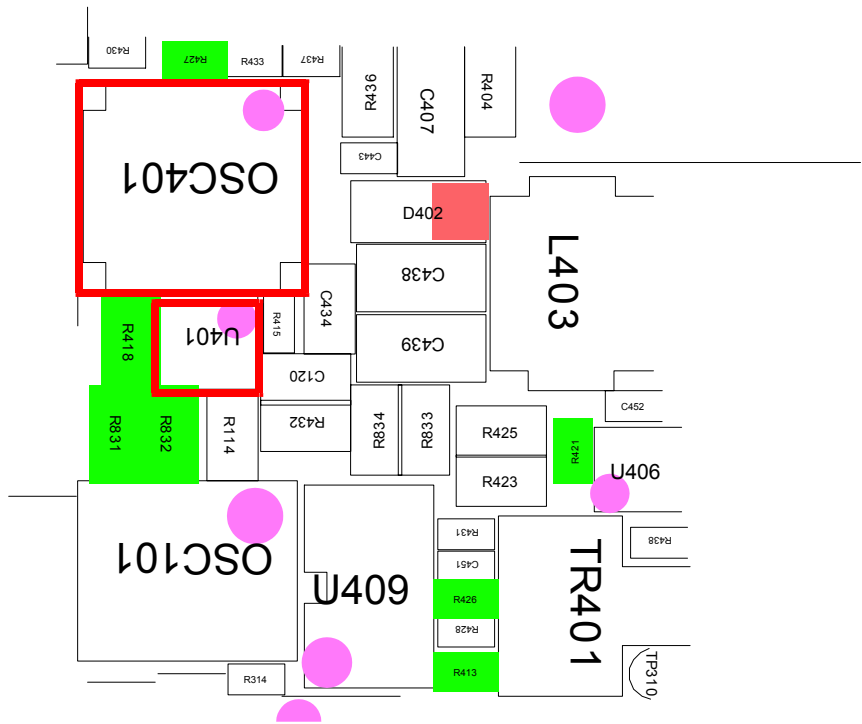
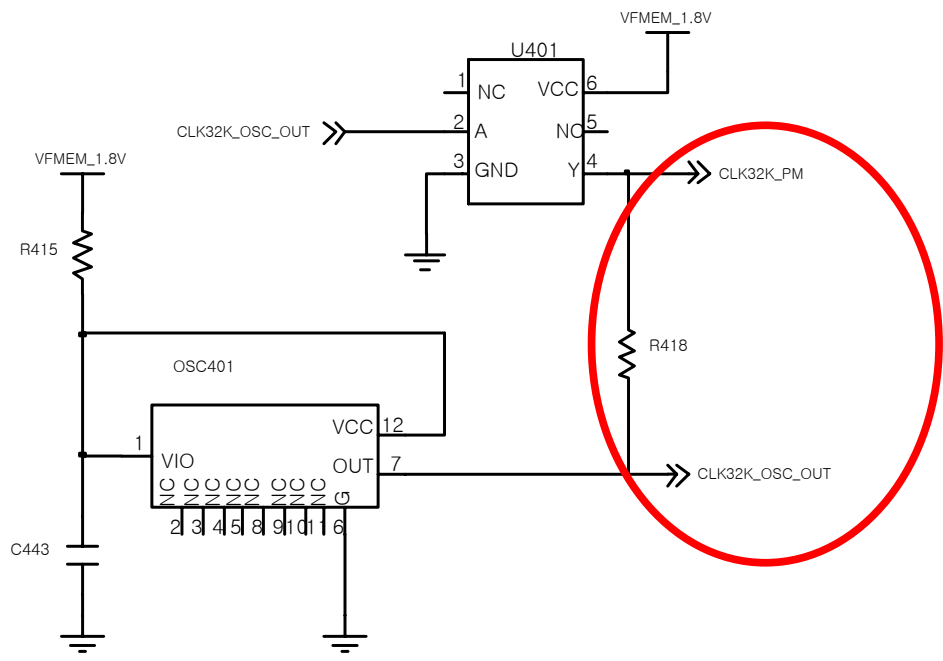

9-1-2. System Initial

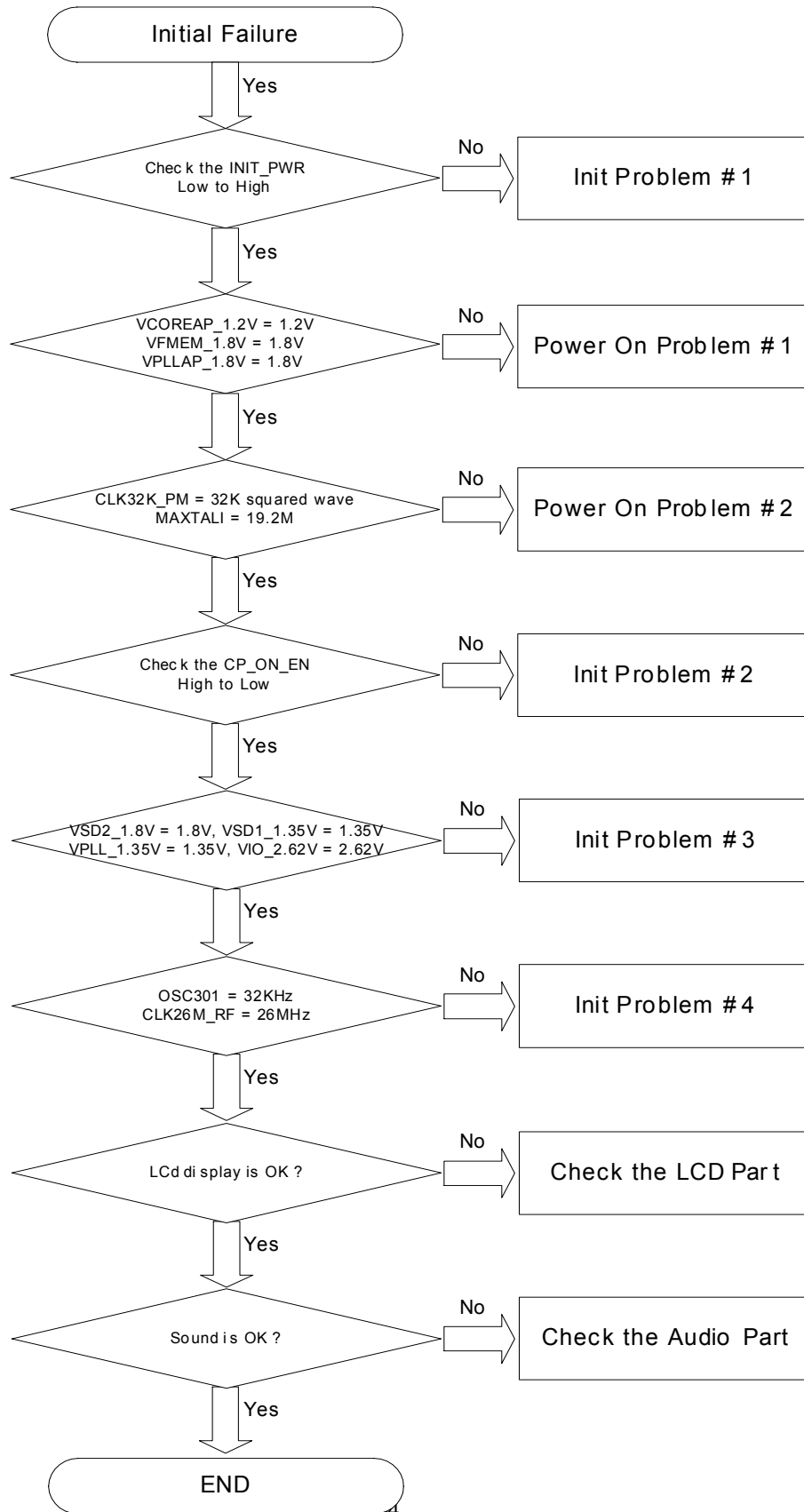

INIT Problem #1

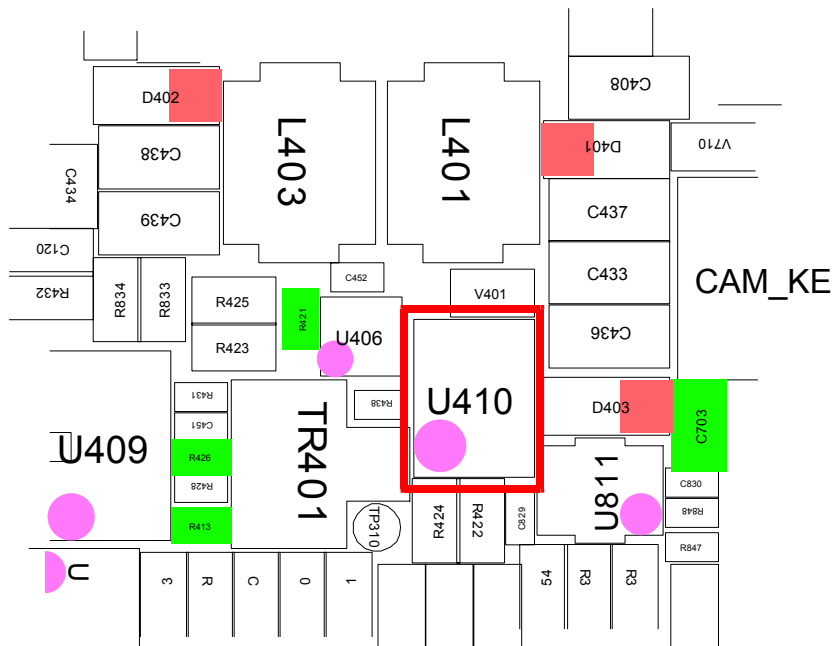
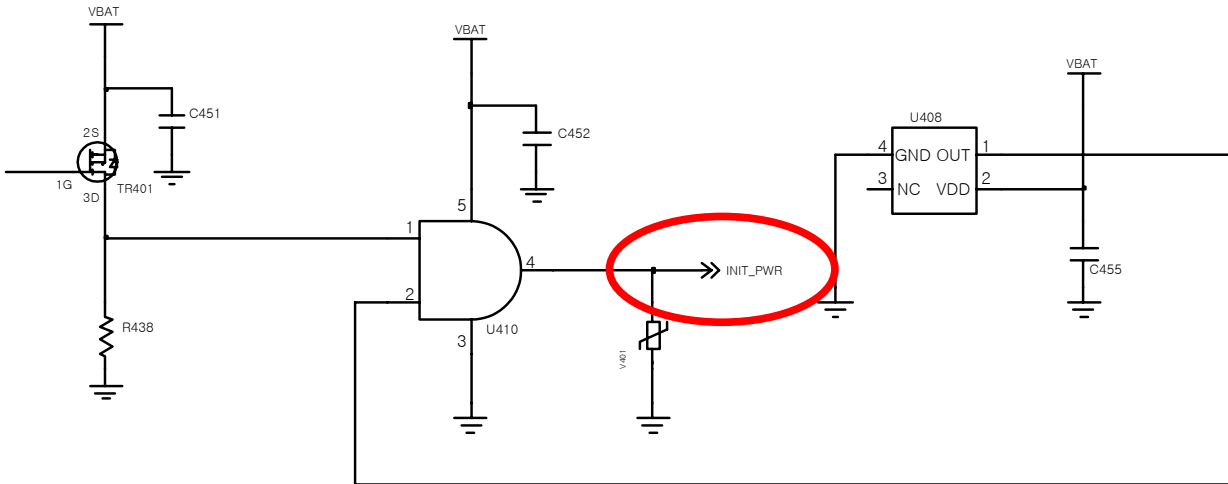

INIT Problem #2

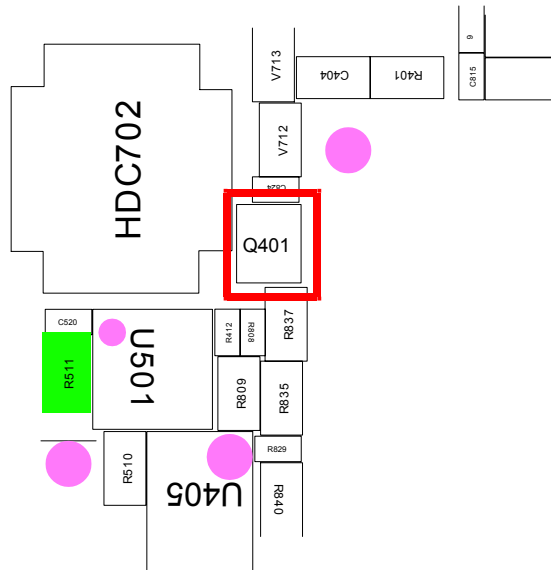
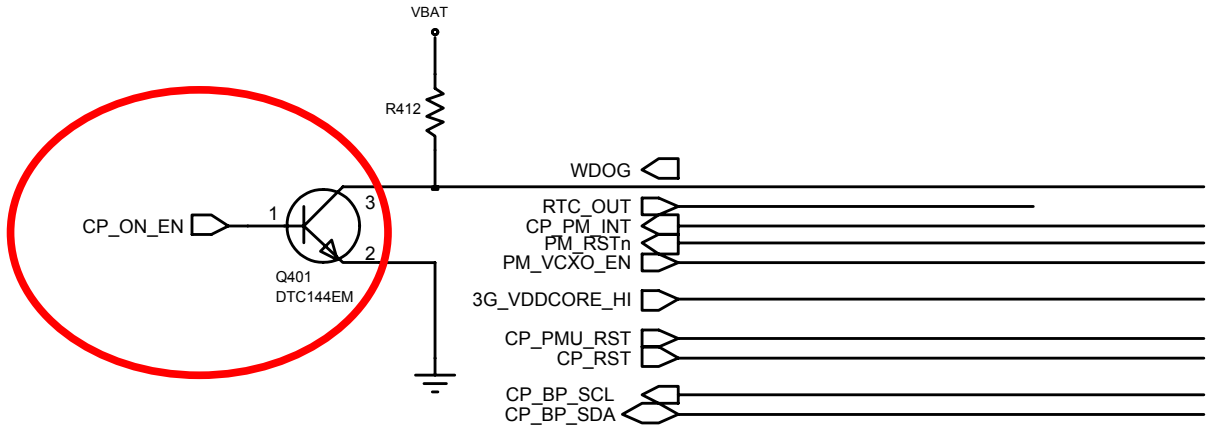

INIT Problem #3

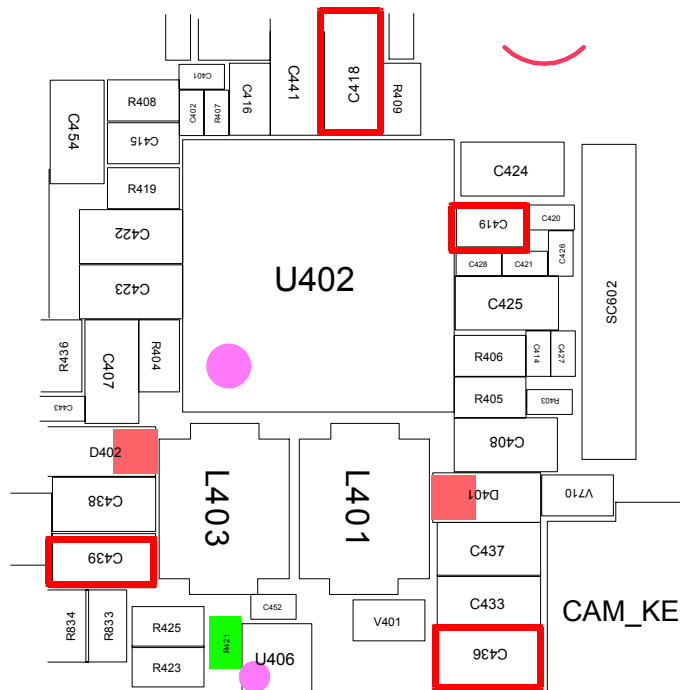
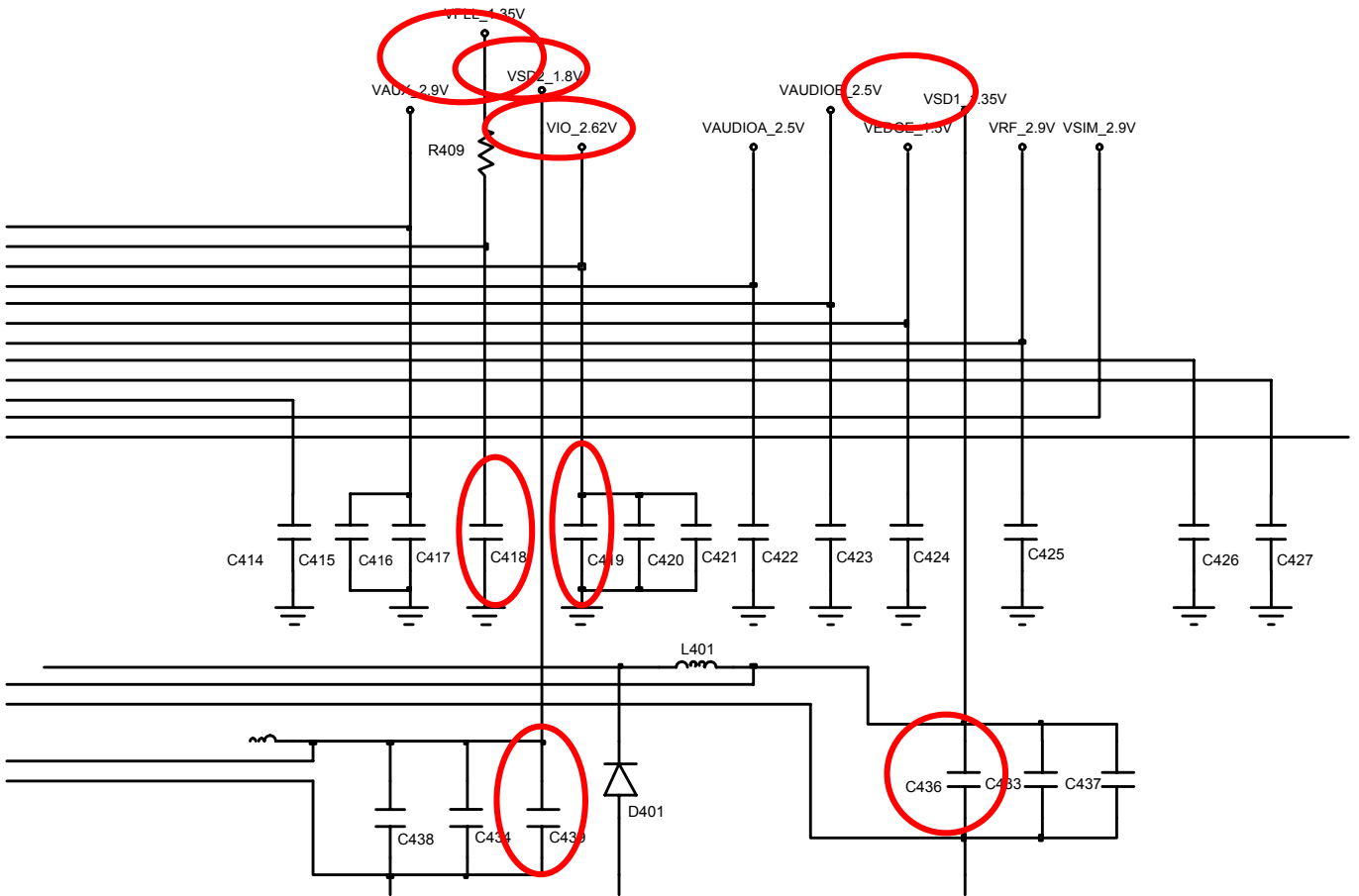

INIT Problem #4

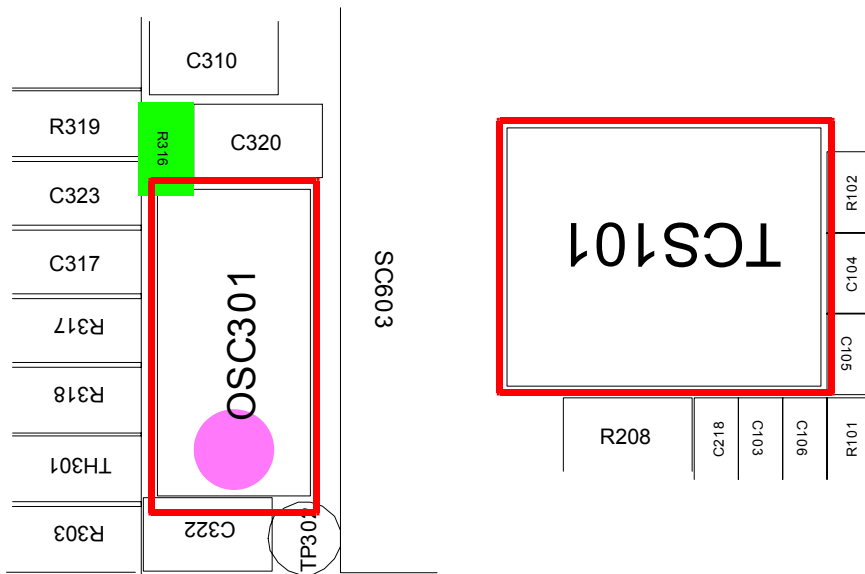
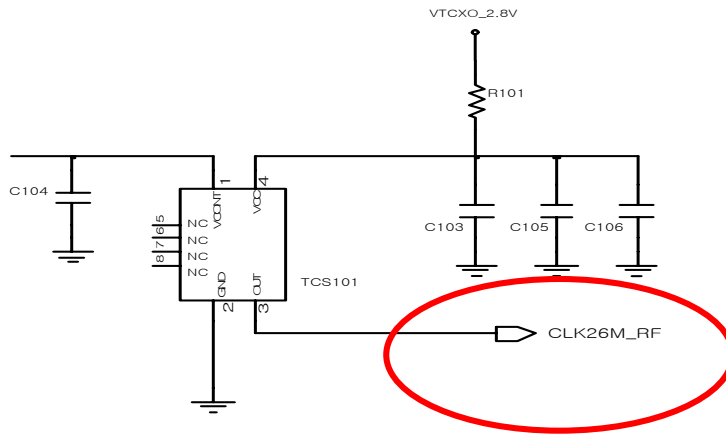
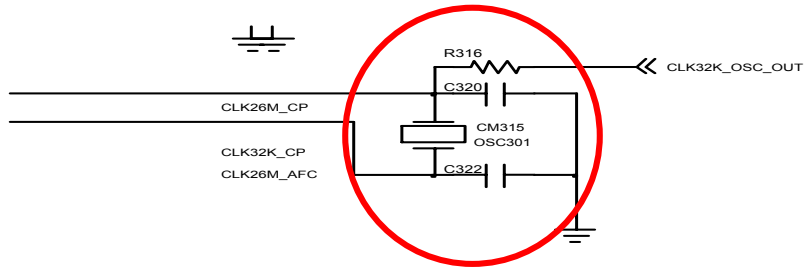

9-1-3. Sim Part

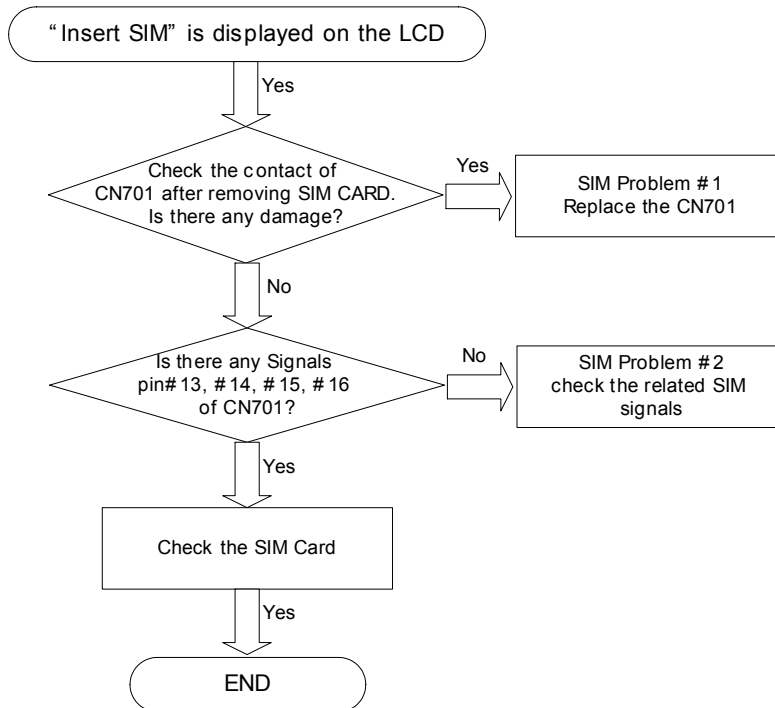

SIM Problem #1

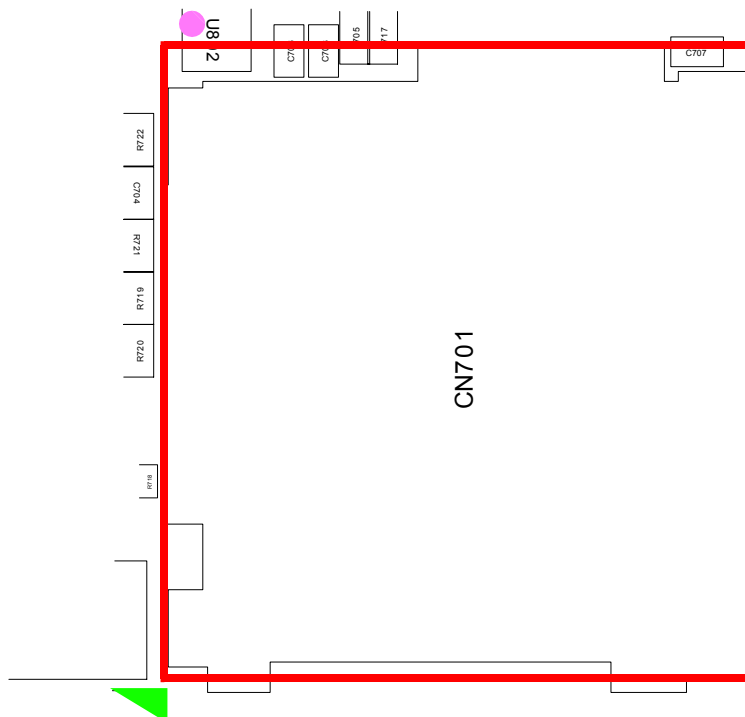

SIM Problem #2

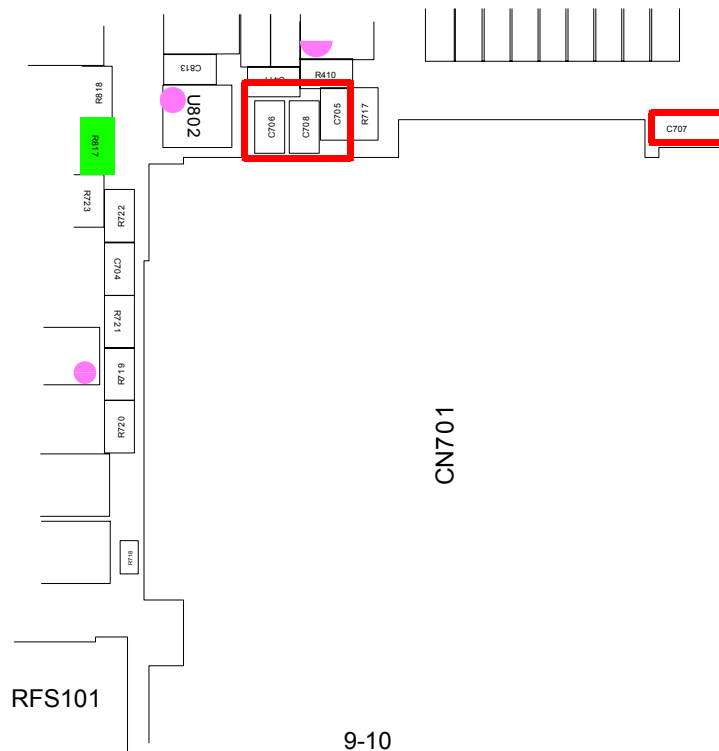
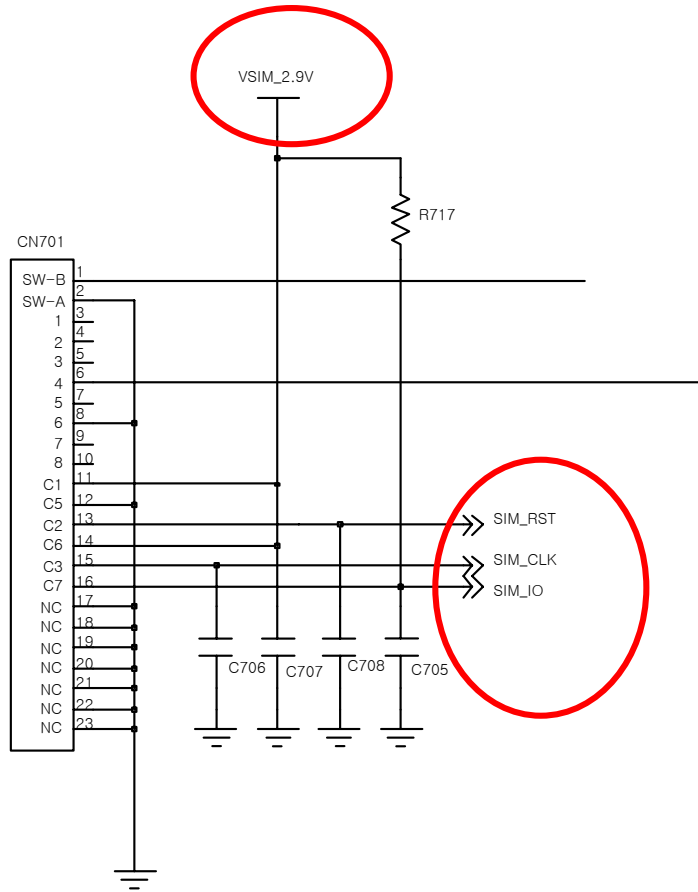

9-1-4. Charging Part

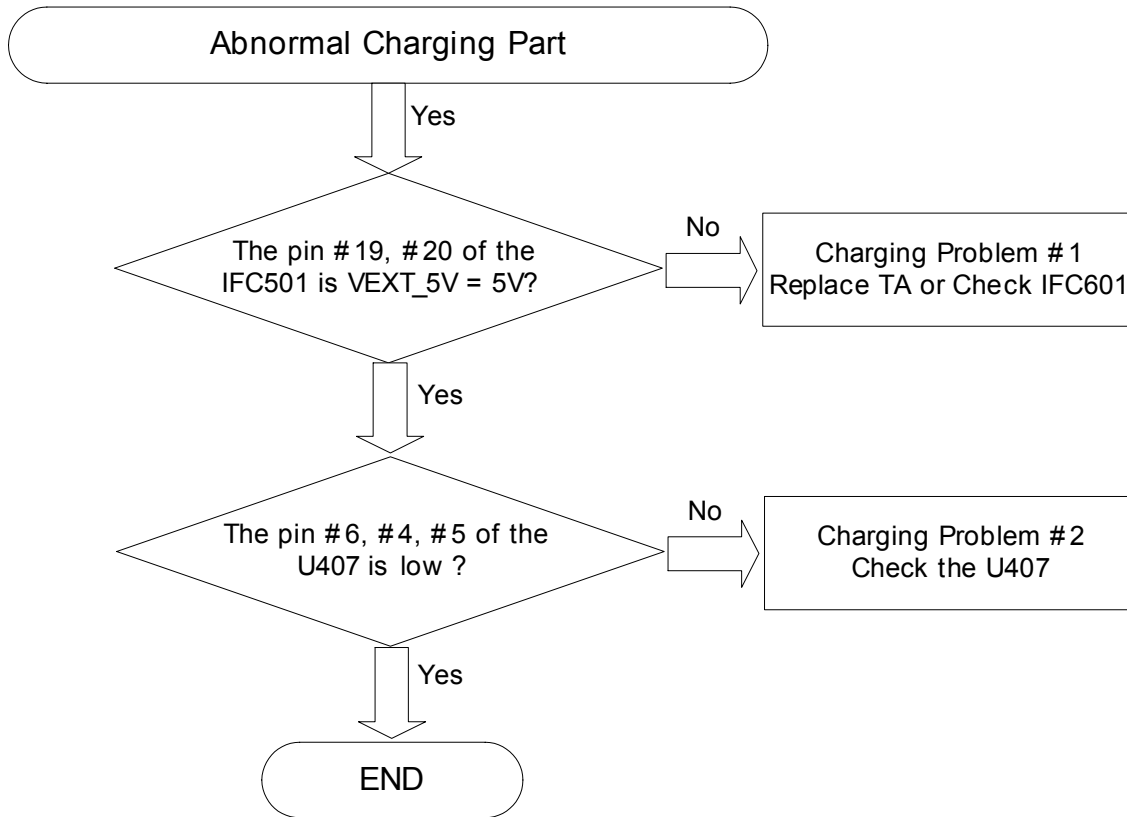

Charging Problem #1

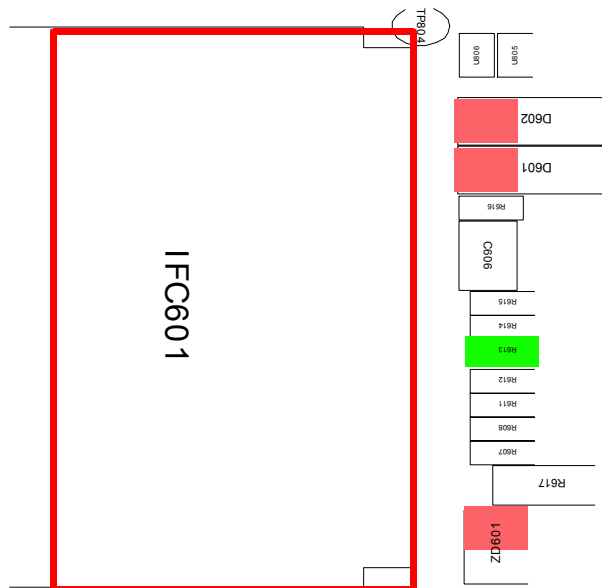

Charging Problem #2

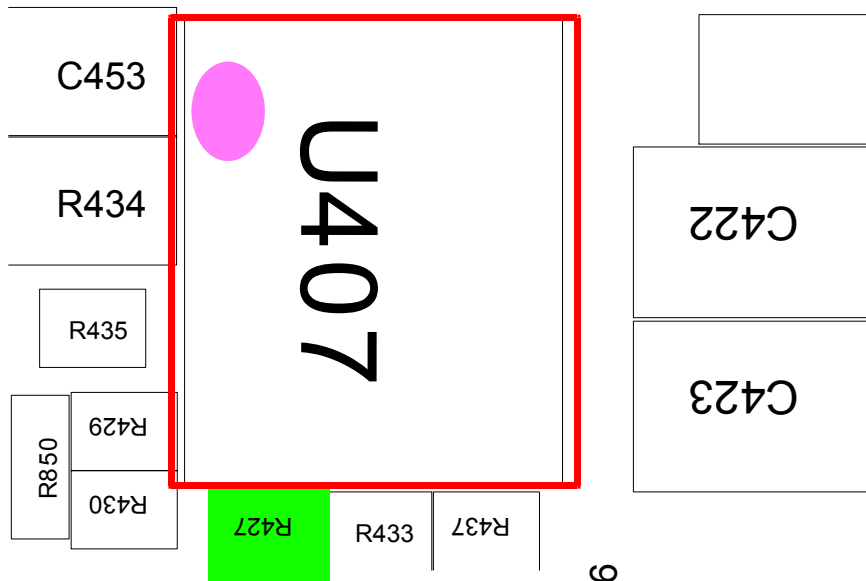
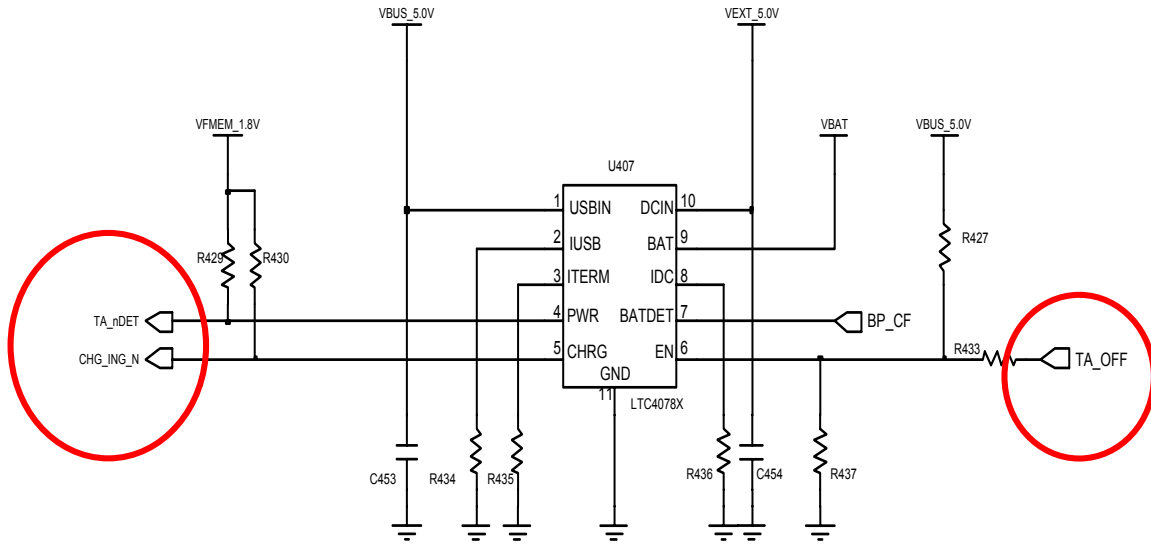

9-1-5. Microphone Part

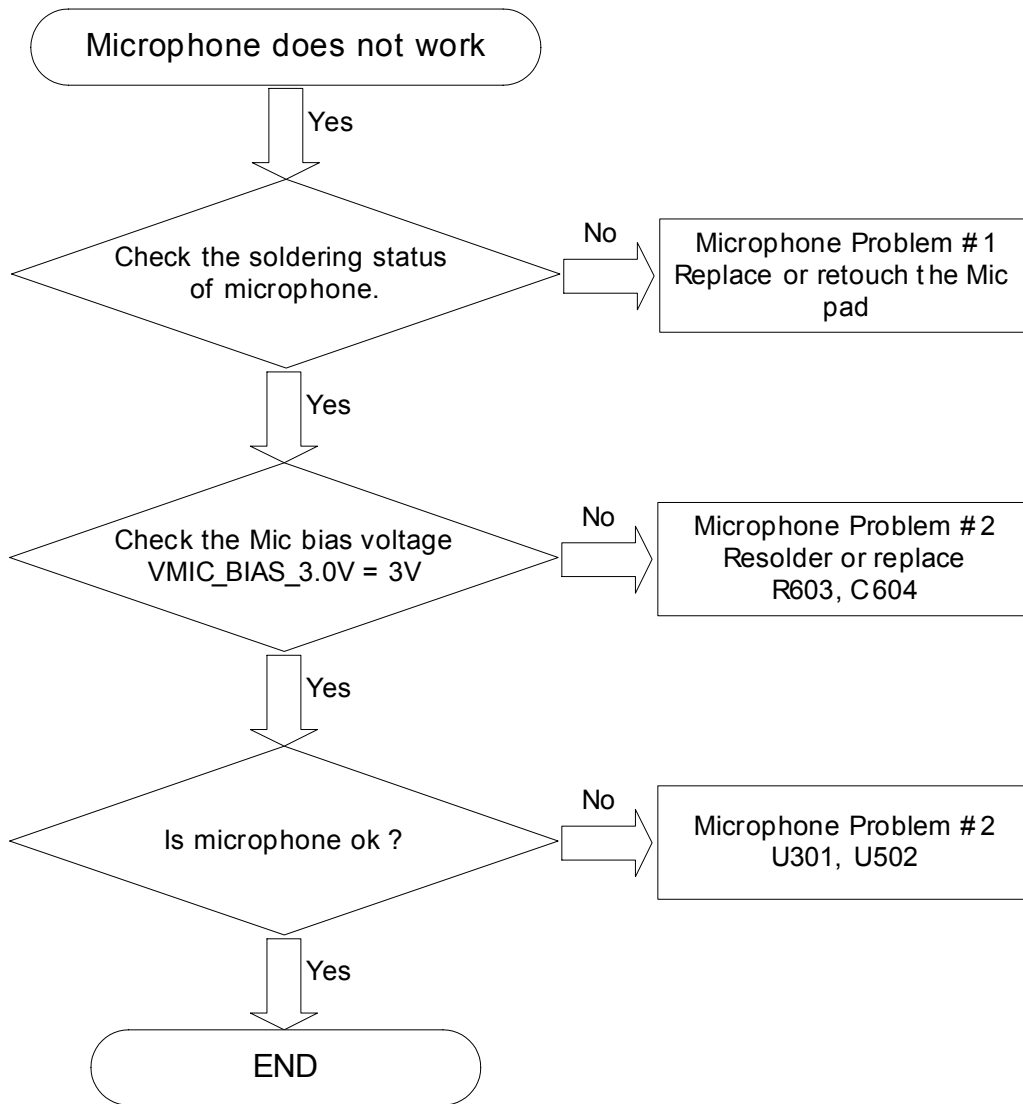

Microphone Problem #1

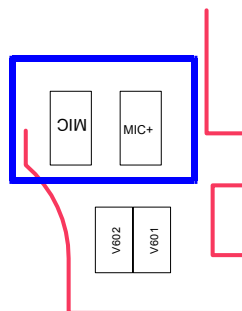

Microphone Problem #2

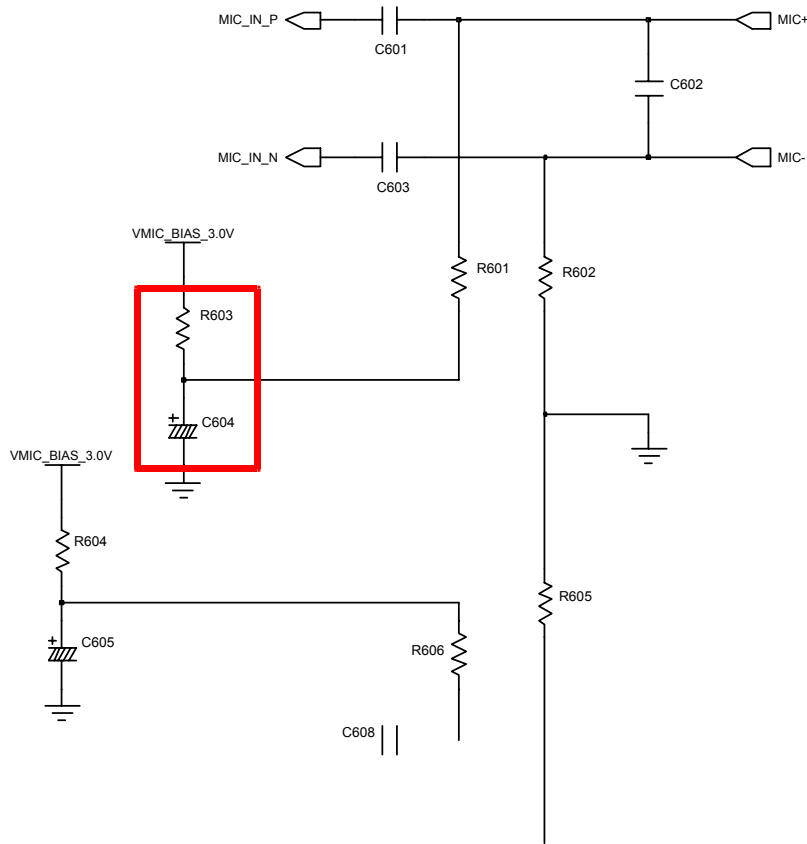

Microphone Problem #3

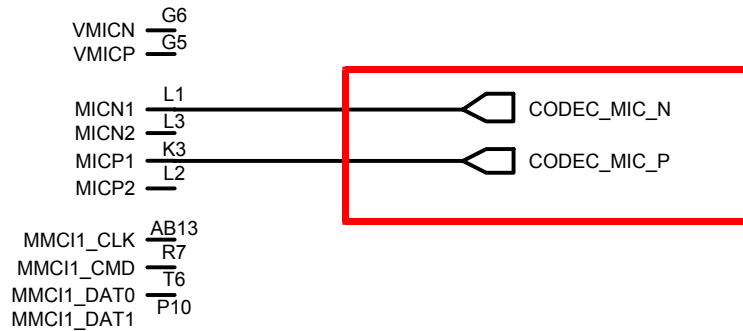

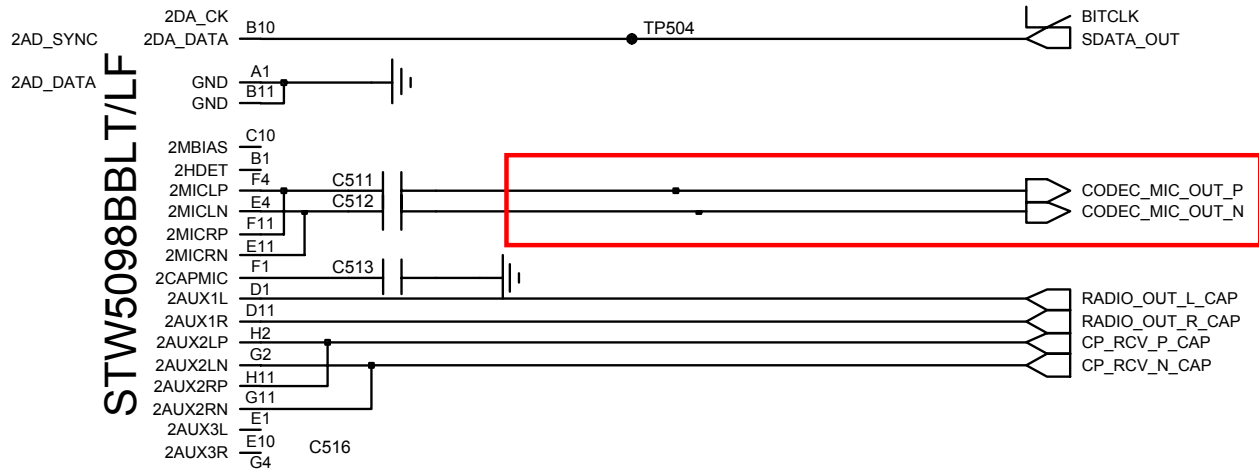
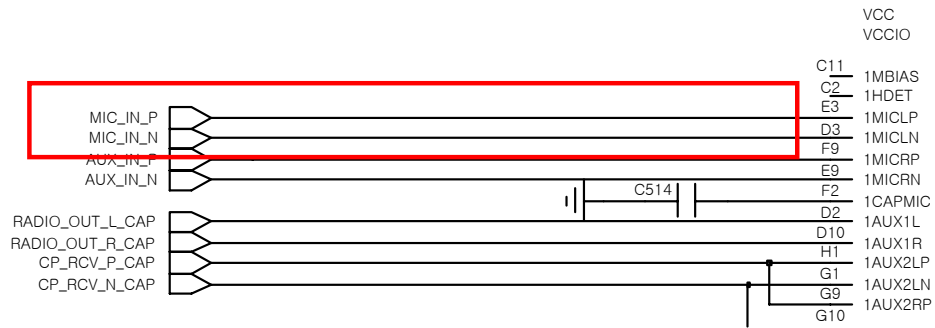

9-1-6. Speaker & Receiver Part

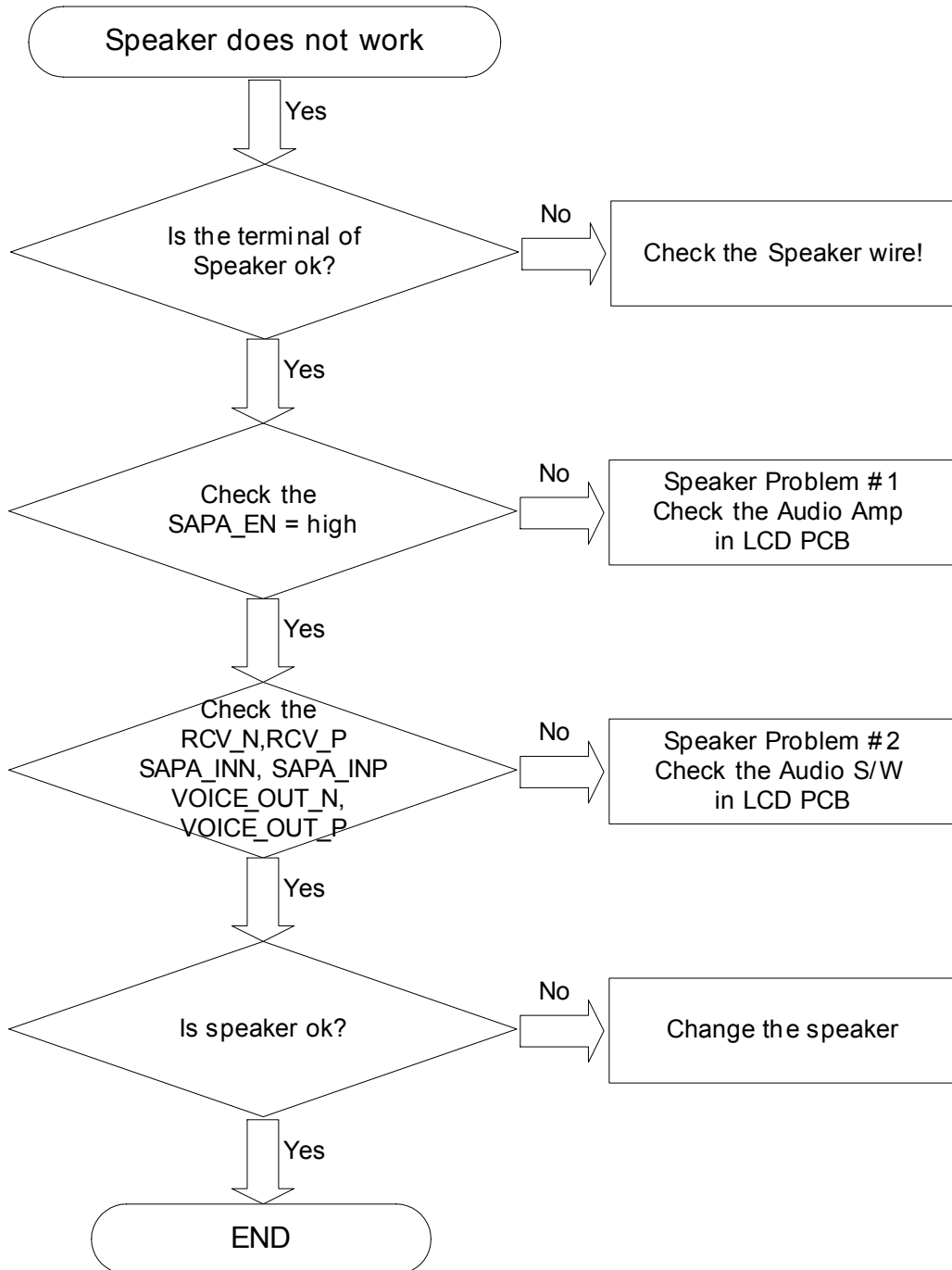

Speaker Problem #1

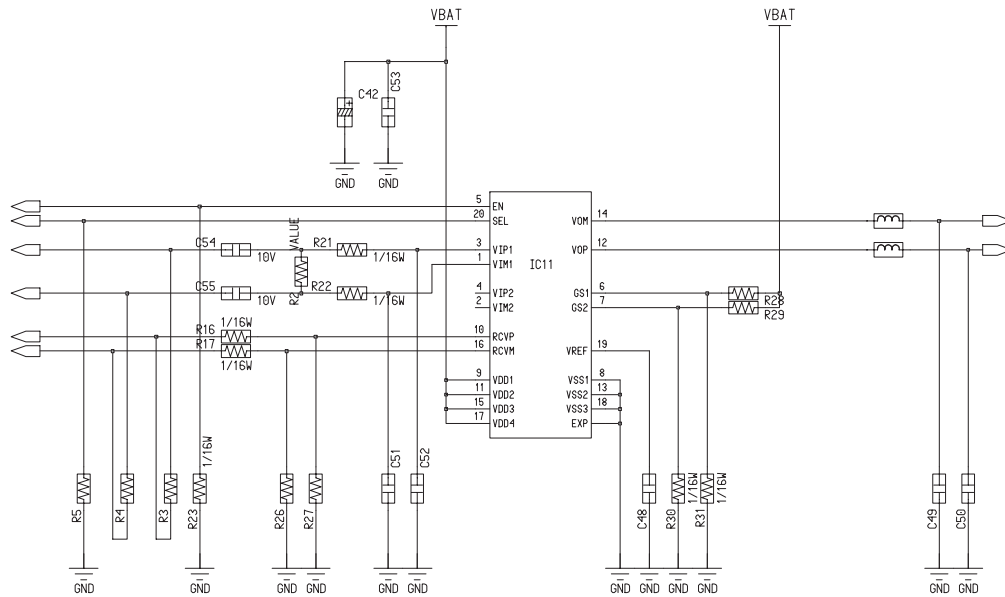

Speaker Problem #2

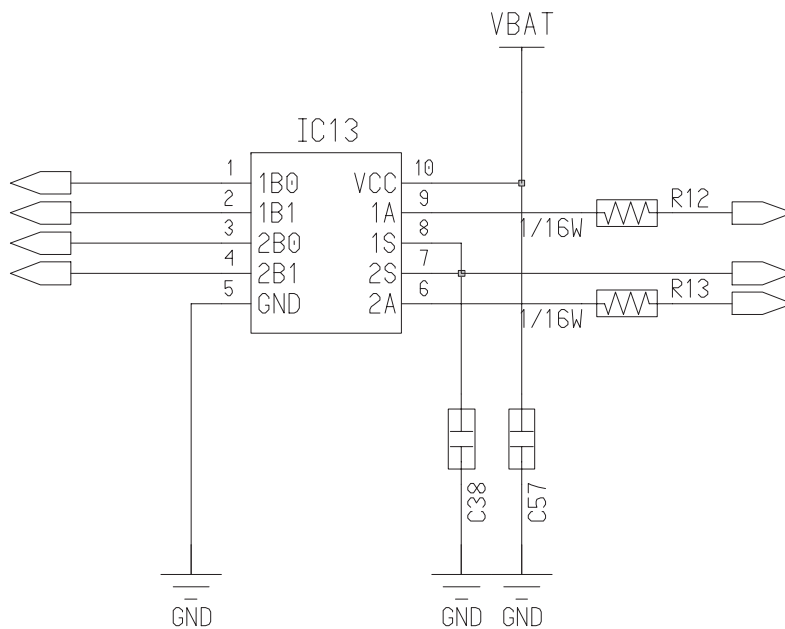

9-1-7. LCD Part

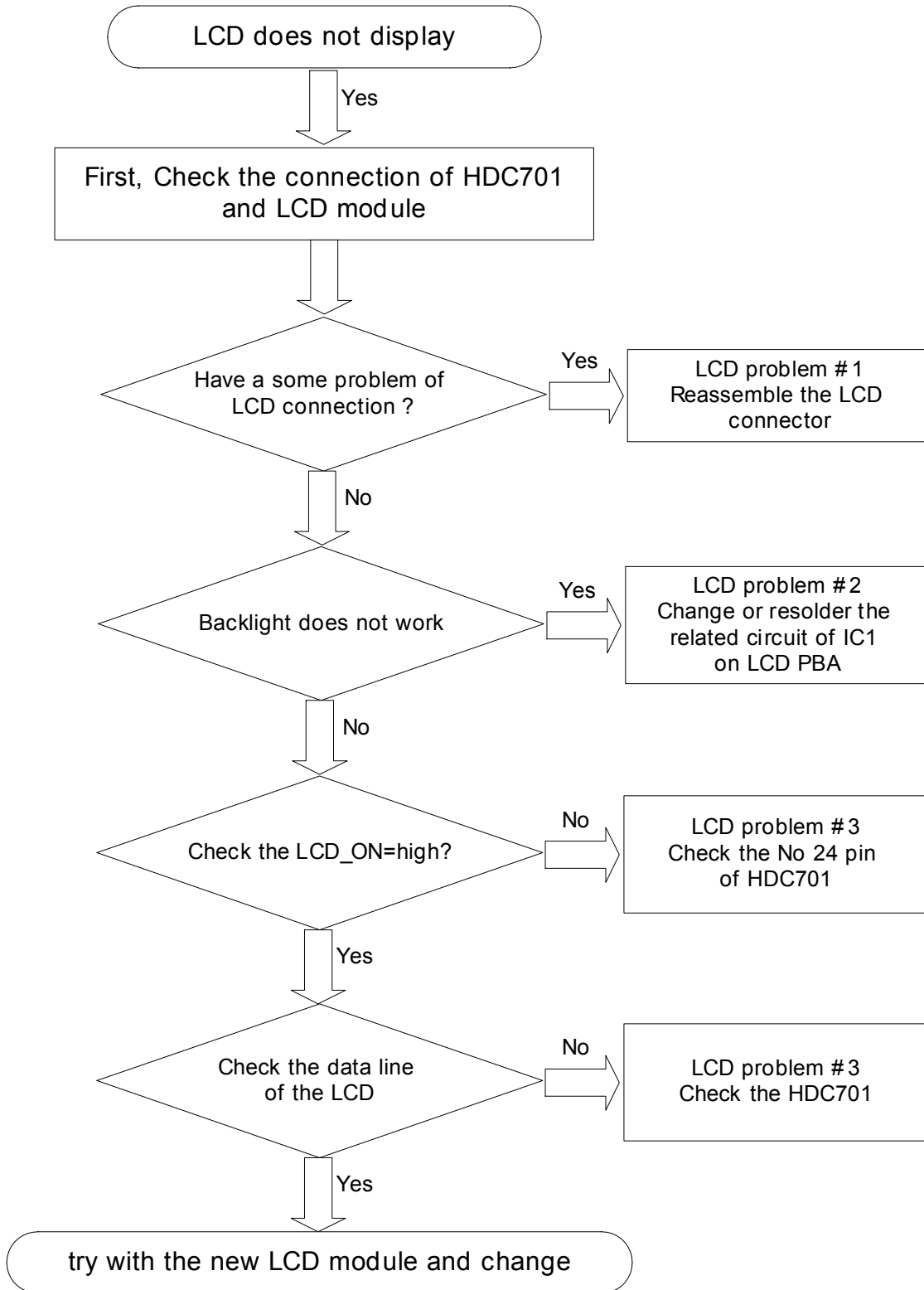

LCD Problem #1

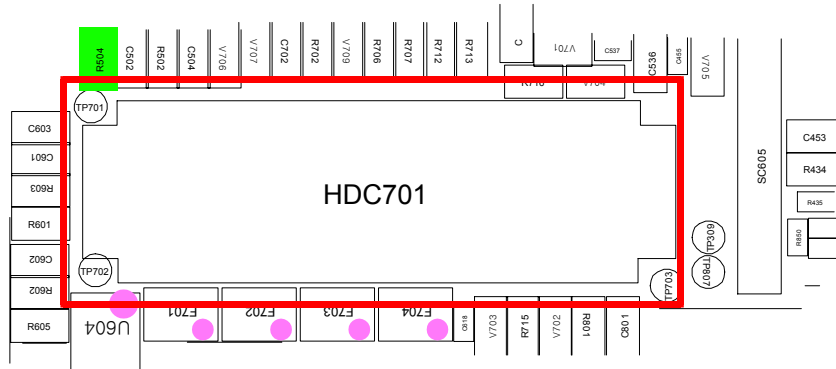

LCD Problem #2

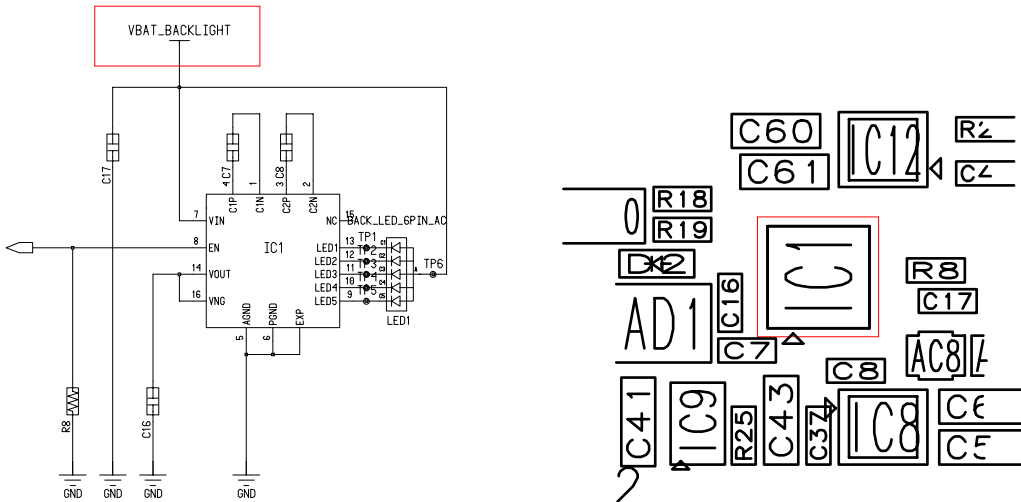

LCD Problem #3

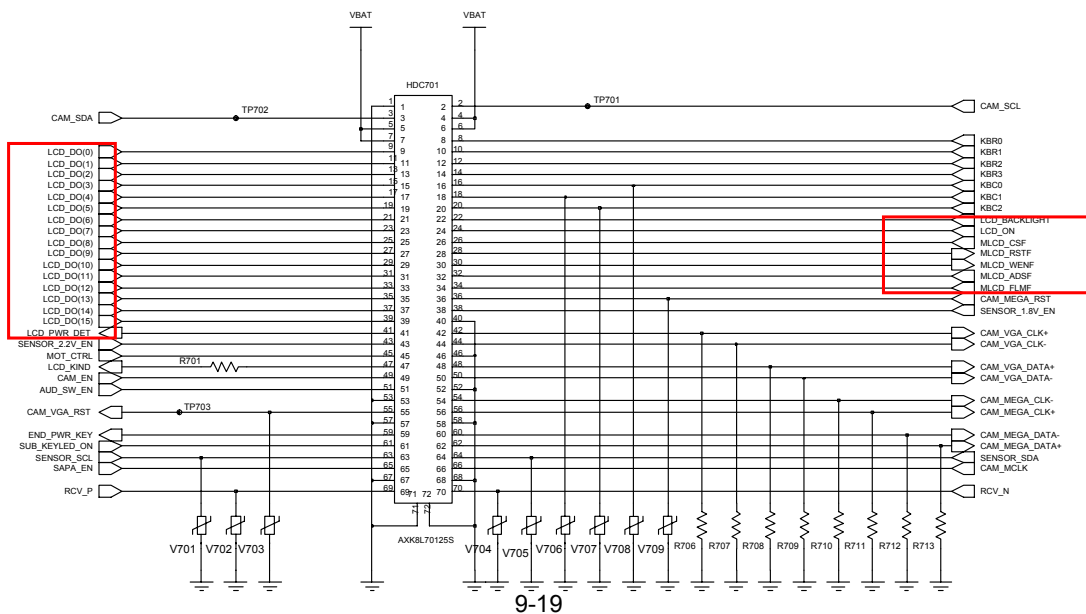

9-1-8. Camera Part

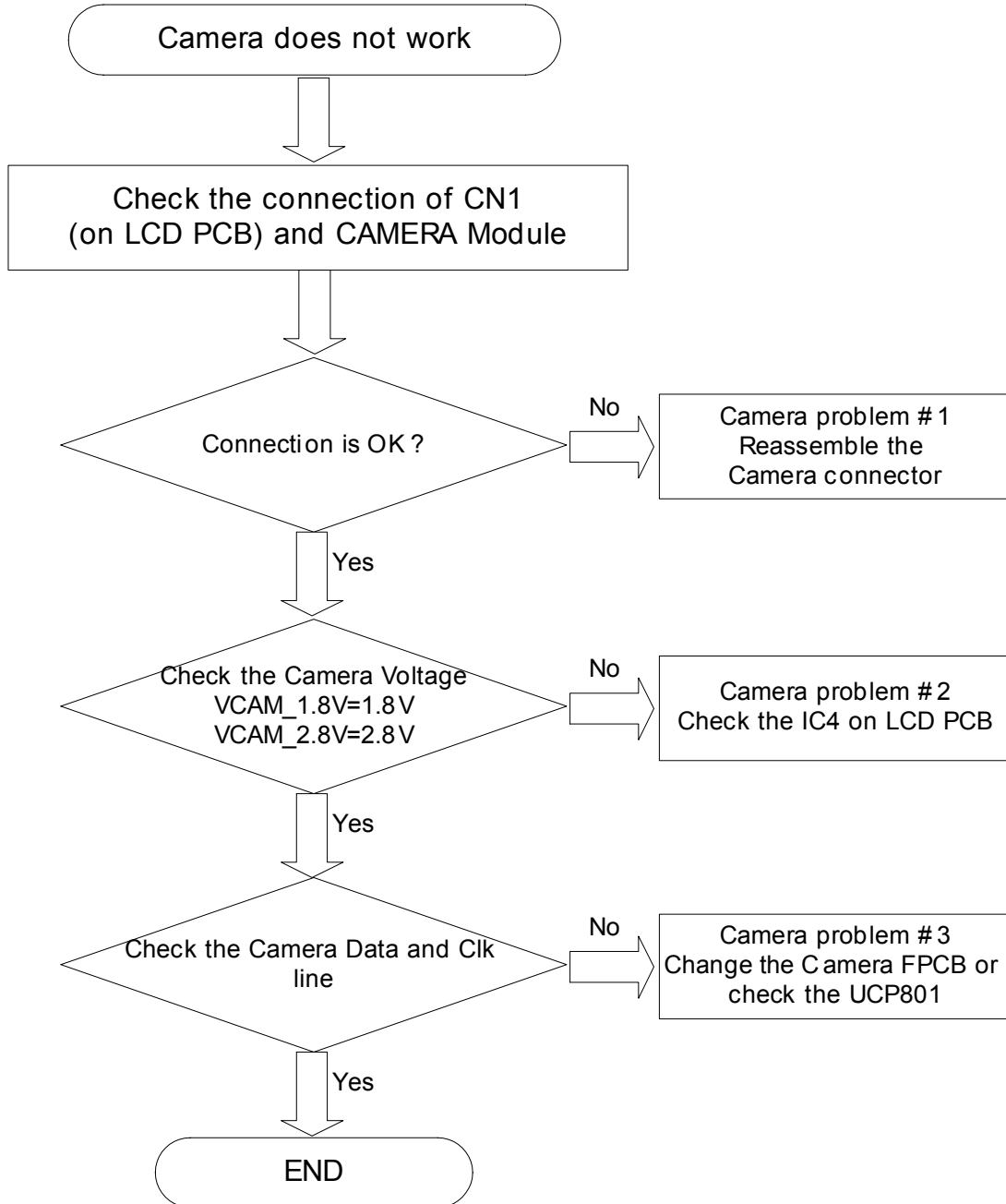

Camera Problem #1

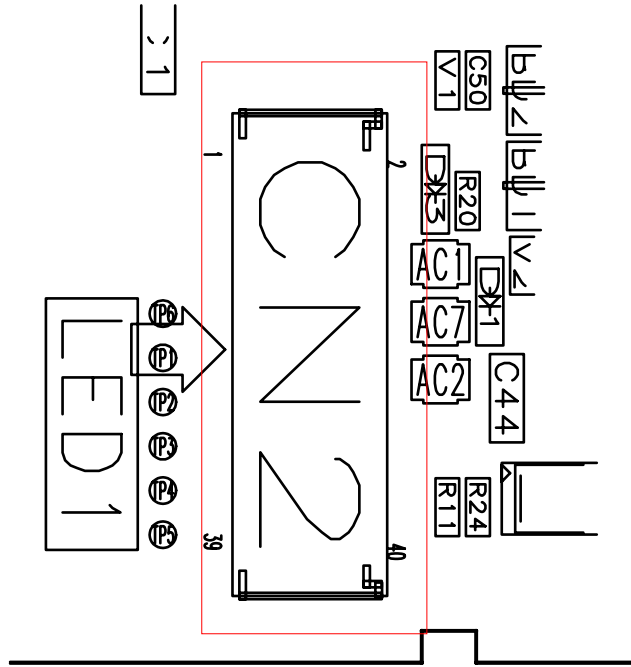

Camera Problem #2

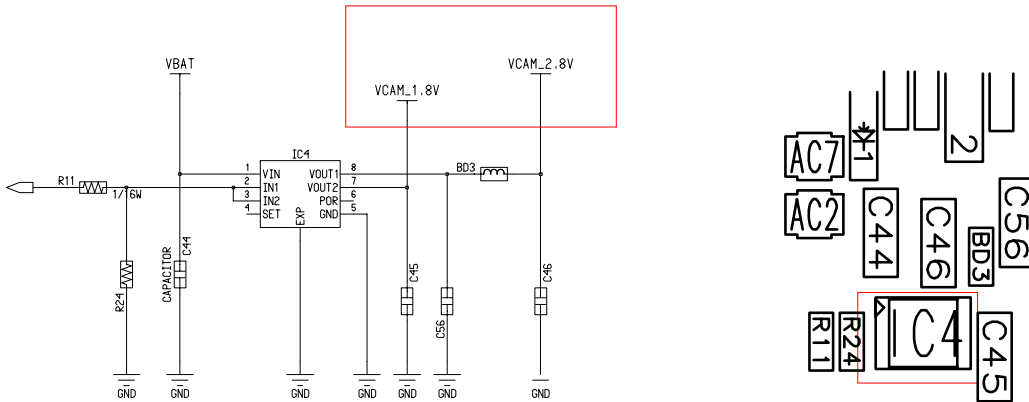

Camera Problem #3

- 3M camera data & clock line

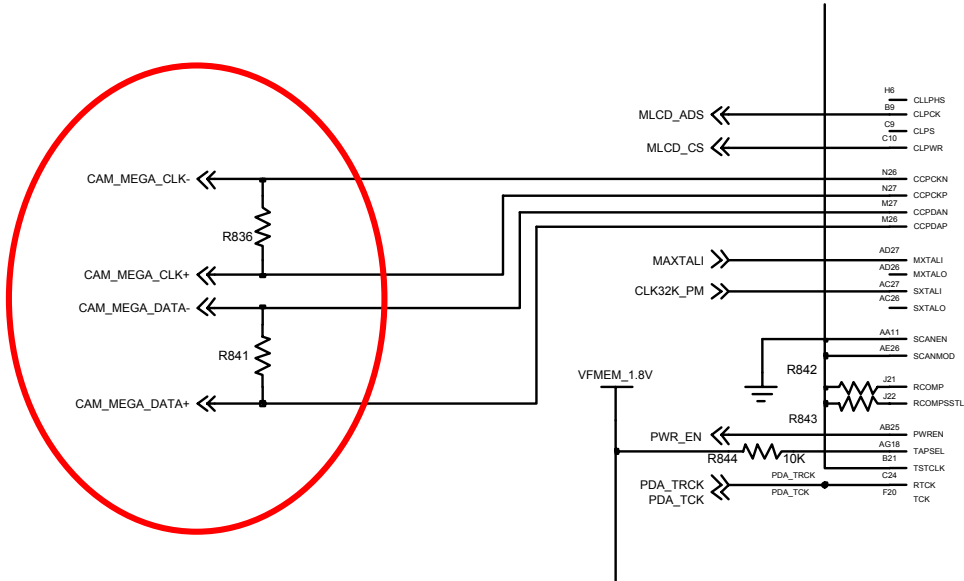

- VGA camera data & clock line

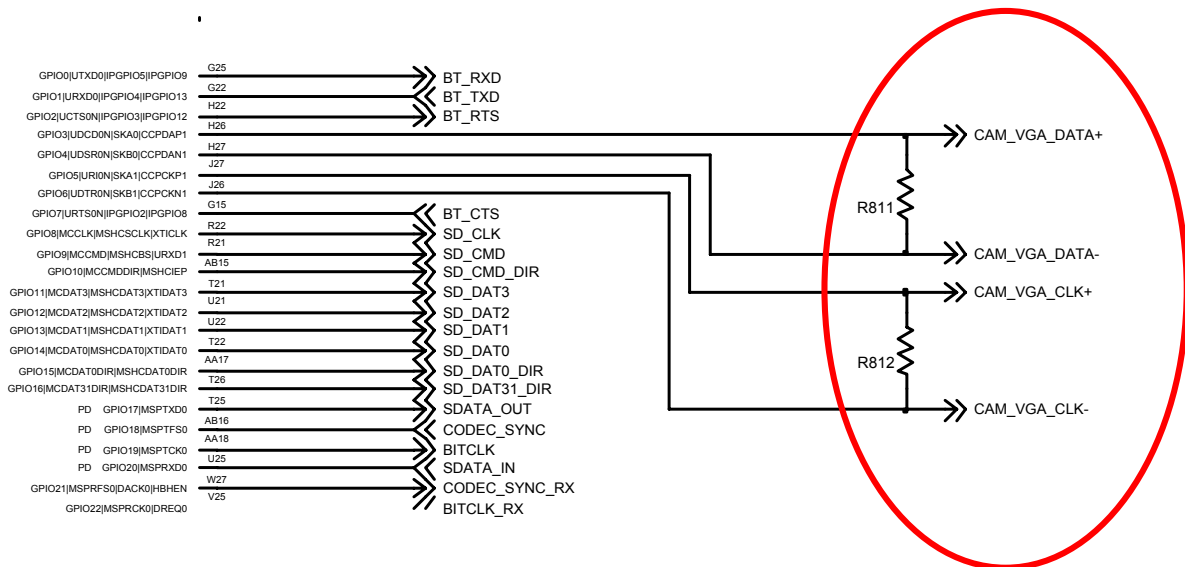

9-1-9. Bluetooth Part

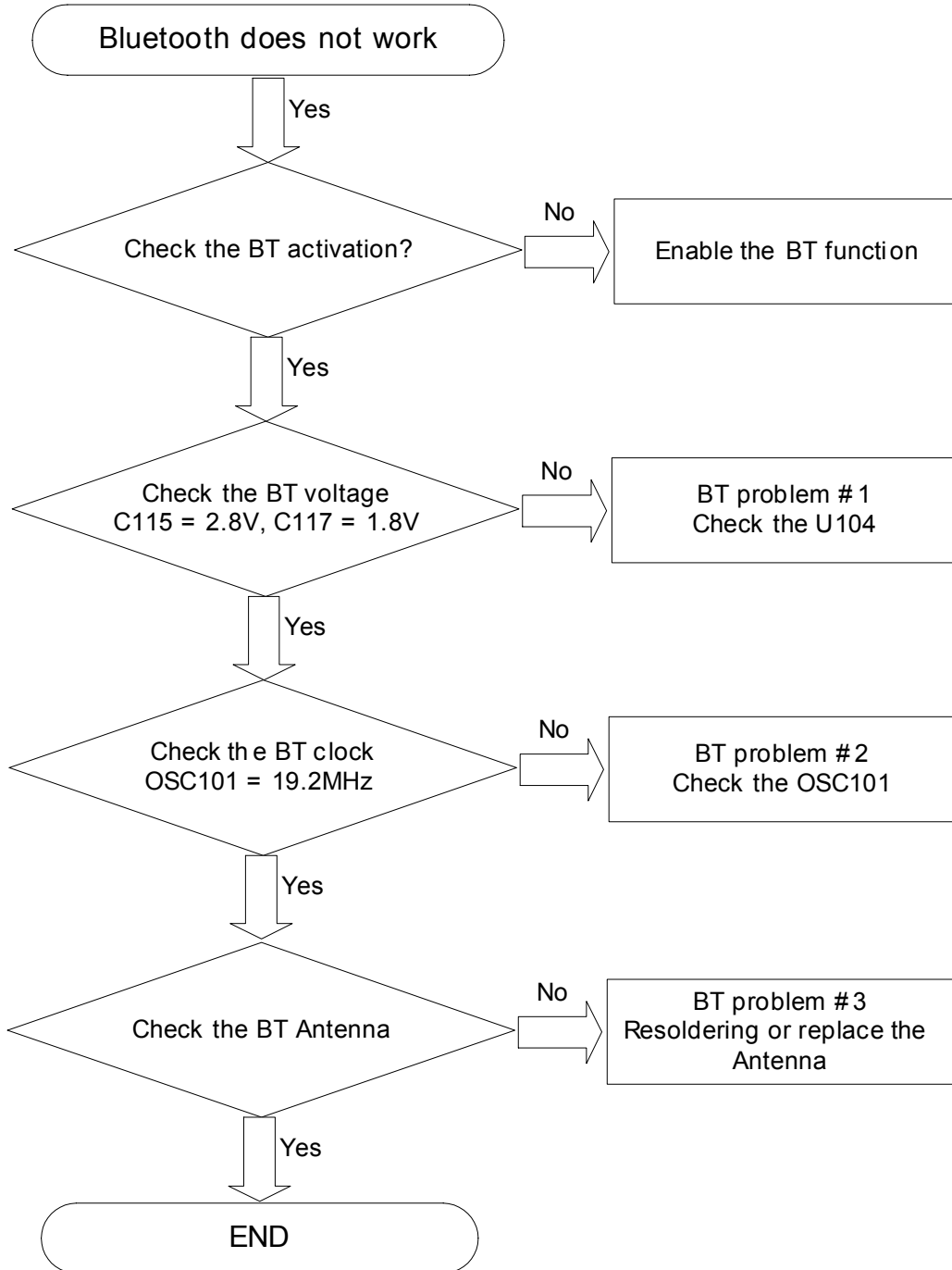

BT Problem #1

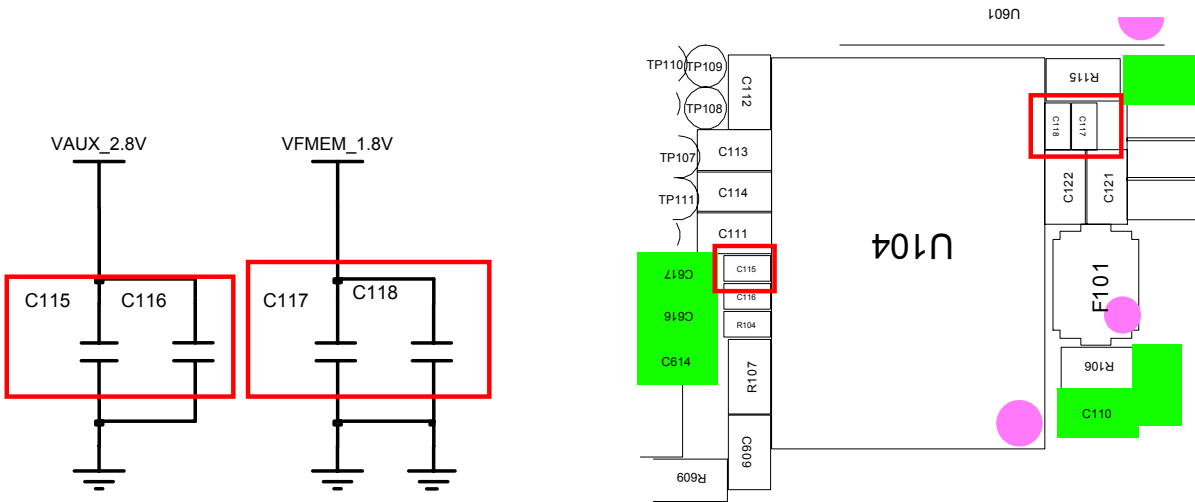

BT Problem #2

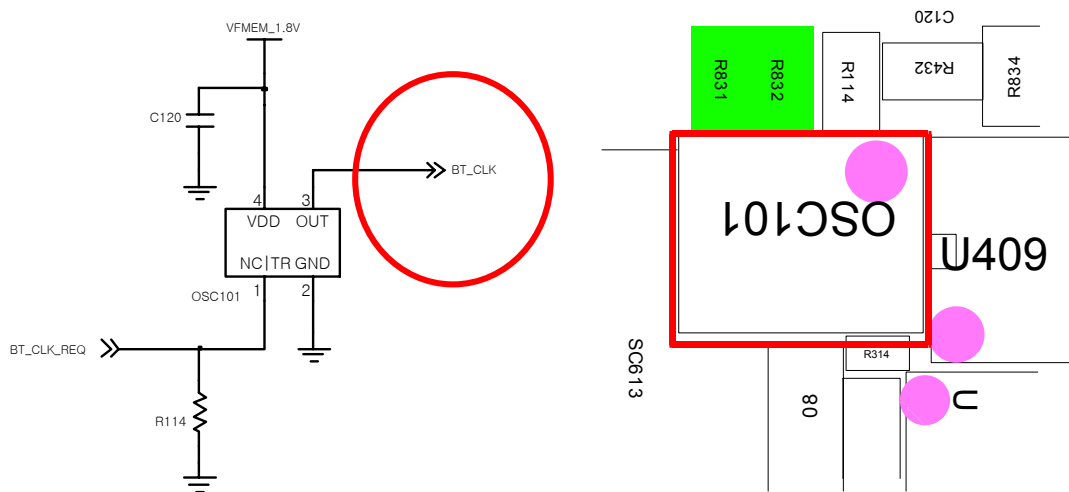

BT Problem #3

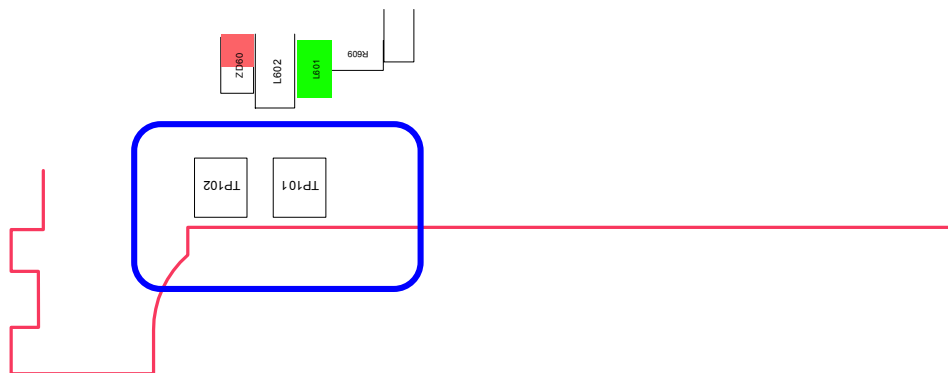

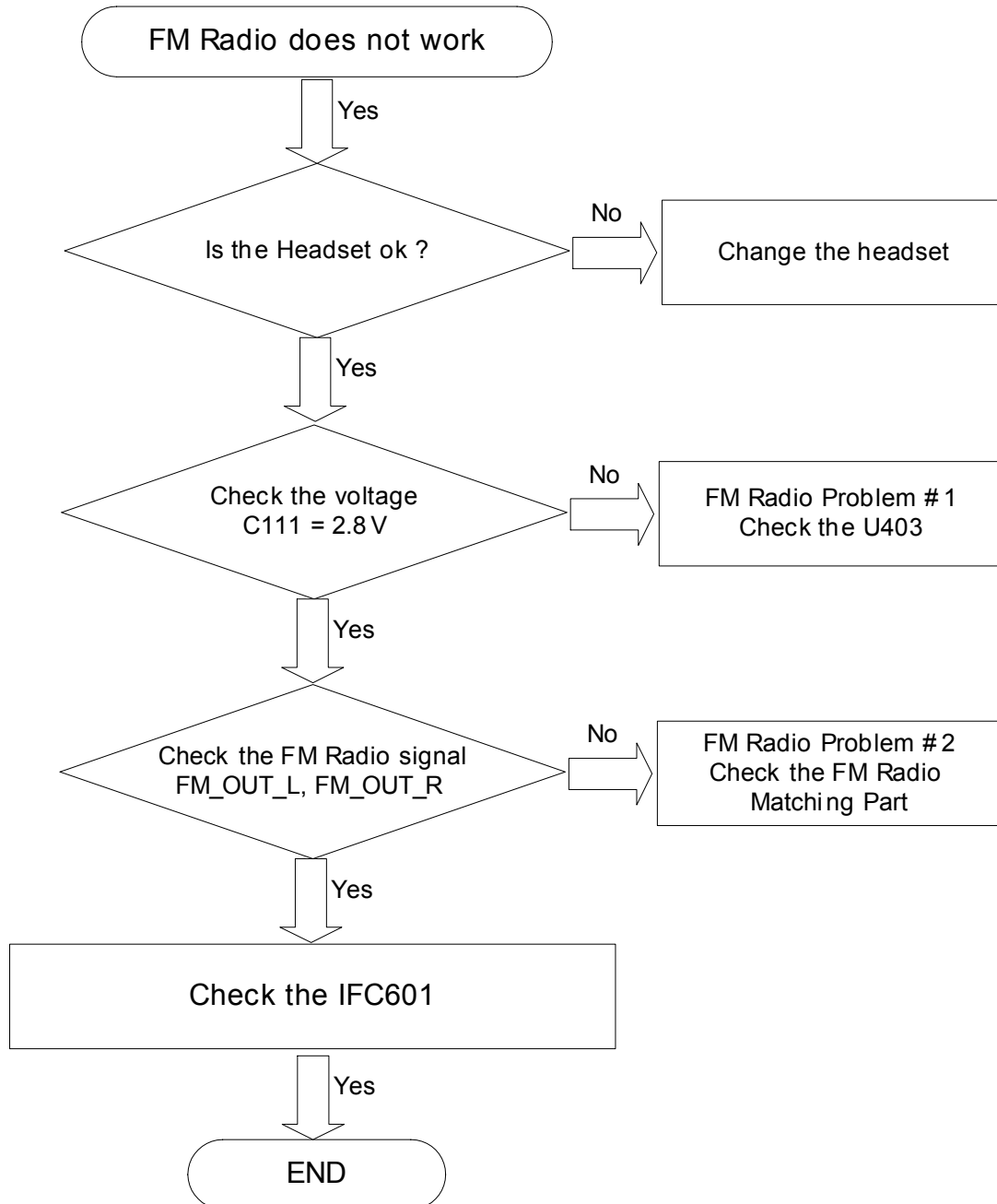
9-1-10. FM Radio Part

FM Radio Problem #1

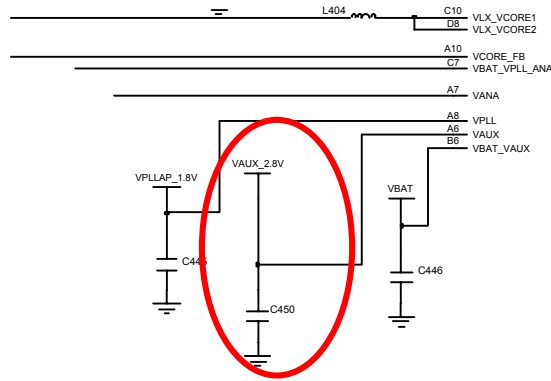

FM Radio Problem #2

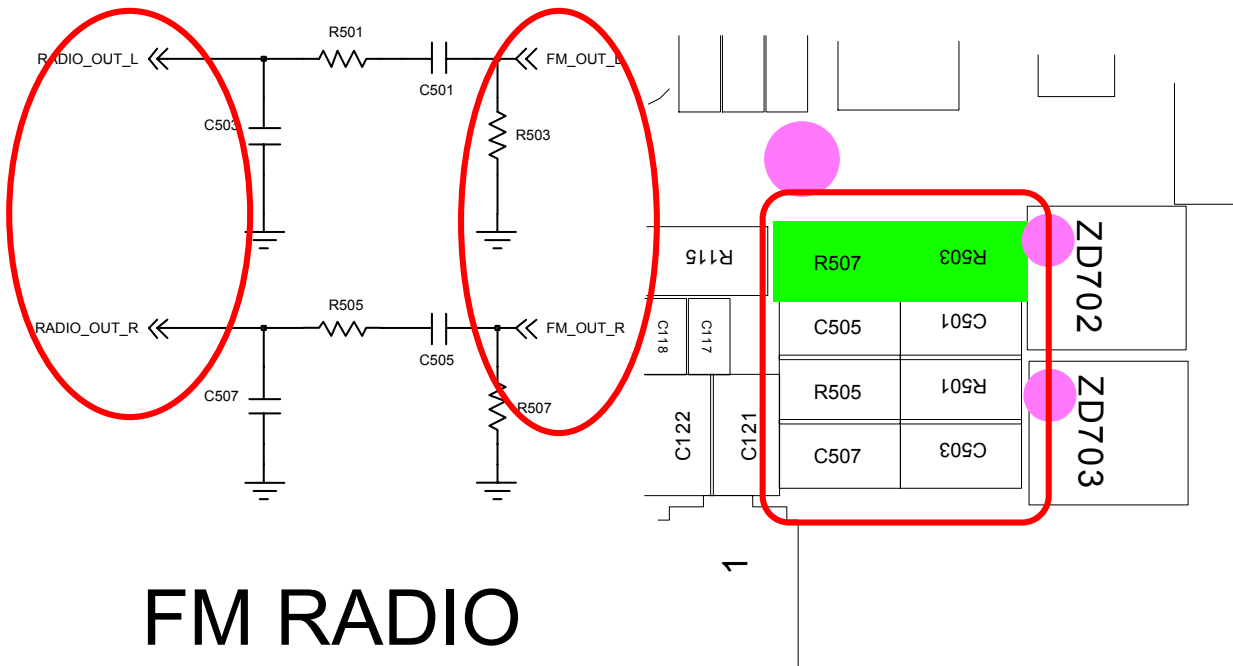

9-2. RF

9-2-1. EGSM RX Part

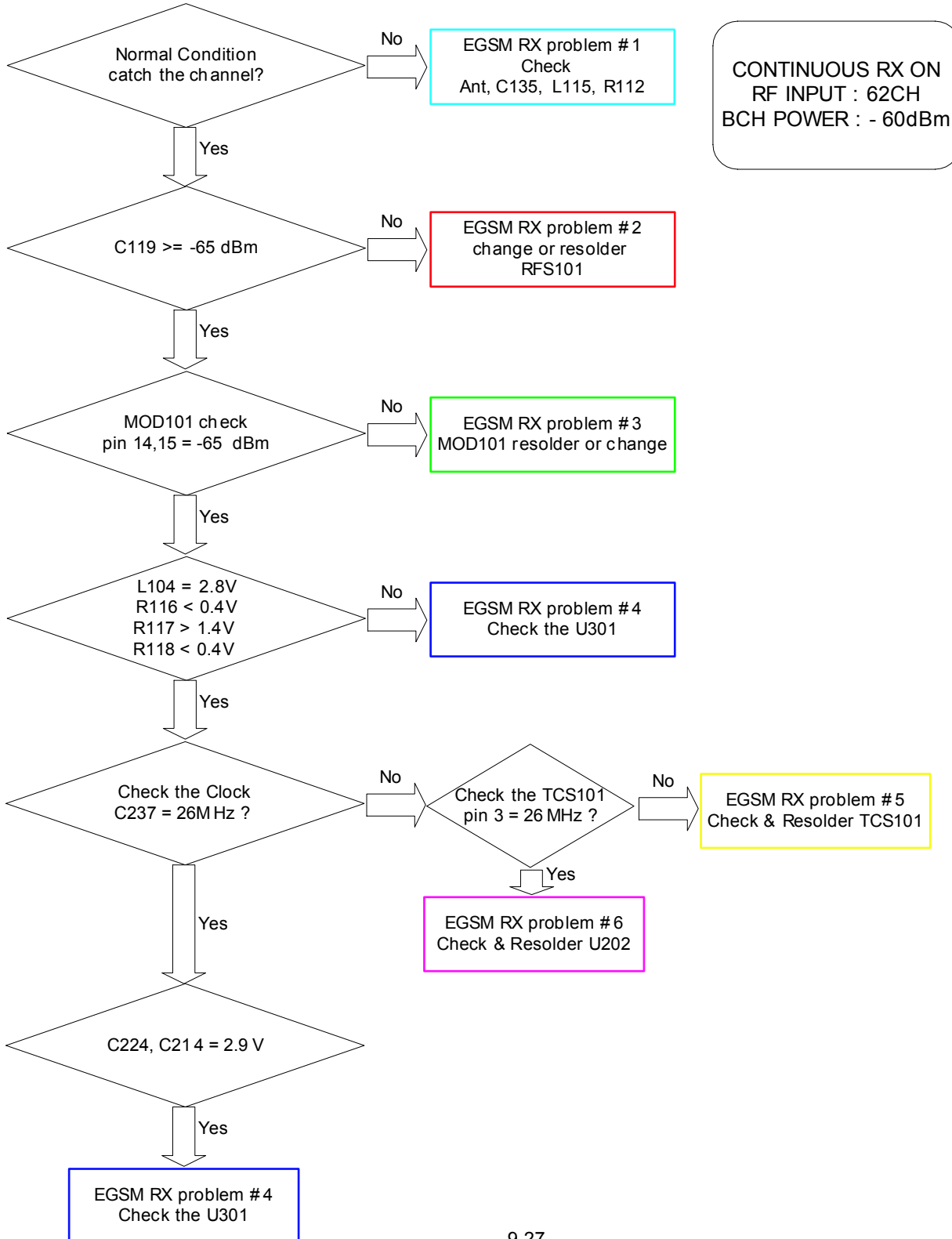

EGSM RX Problem #1,2

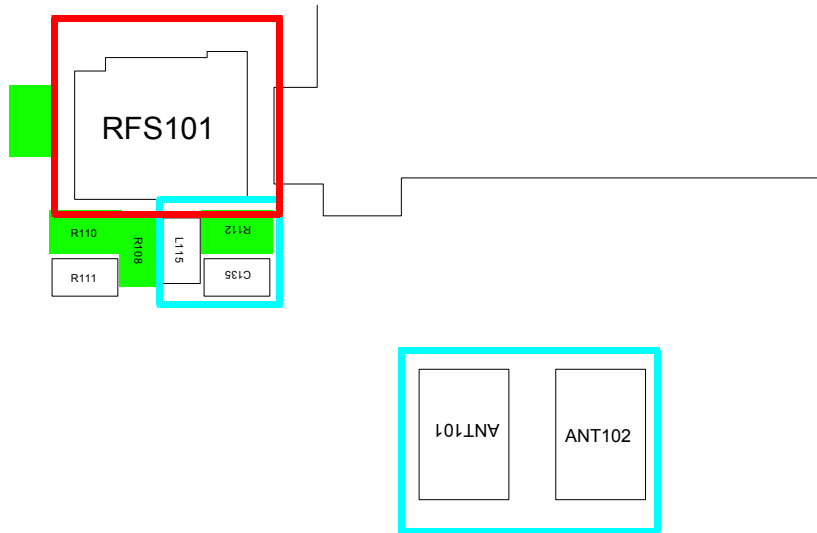

EGSM RX Problem #3,4,5,6

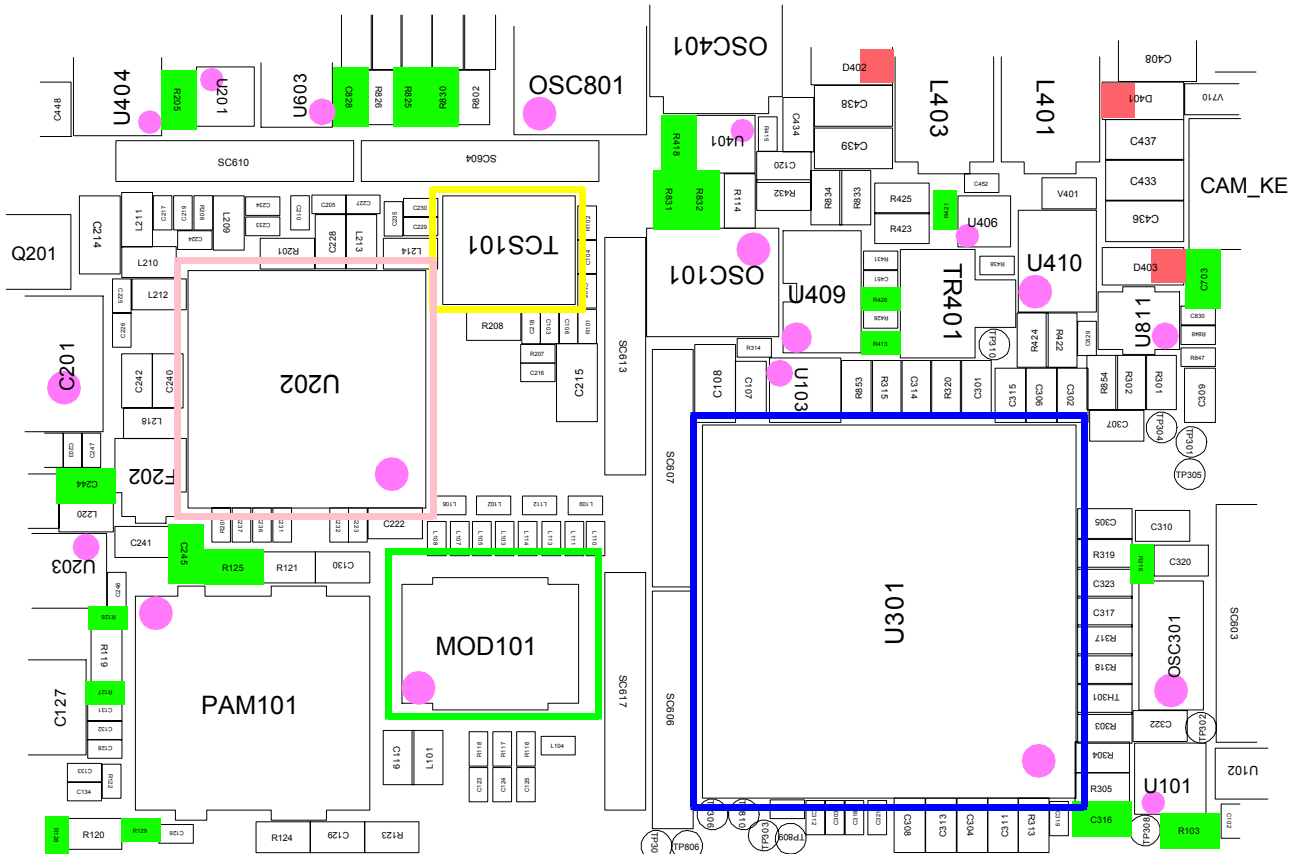

9-2-2. DCS RX Part

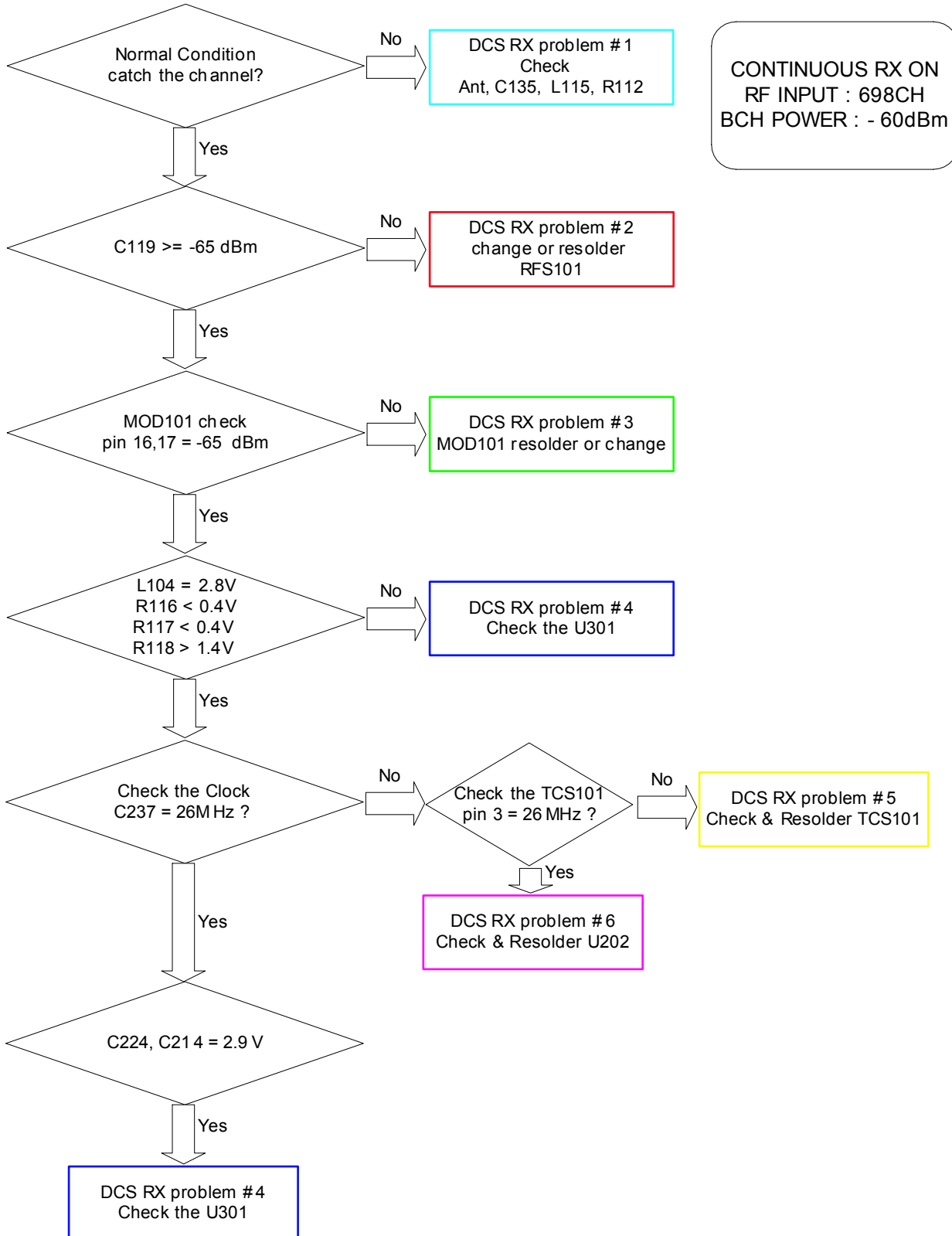

CONTINUOUS RX ON
RF INPUT : 698CH
BCH POWER : - 60dBm

Flow Chart of Troubleshooting and Circuit Diagrams

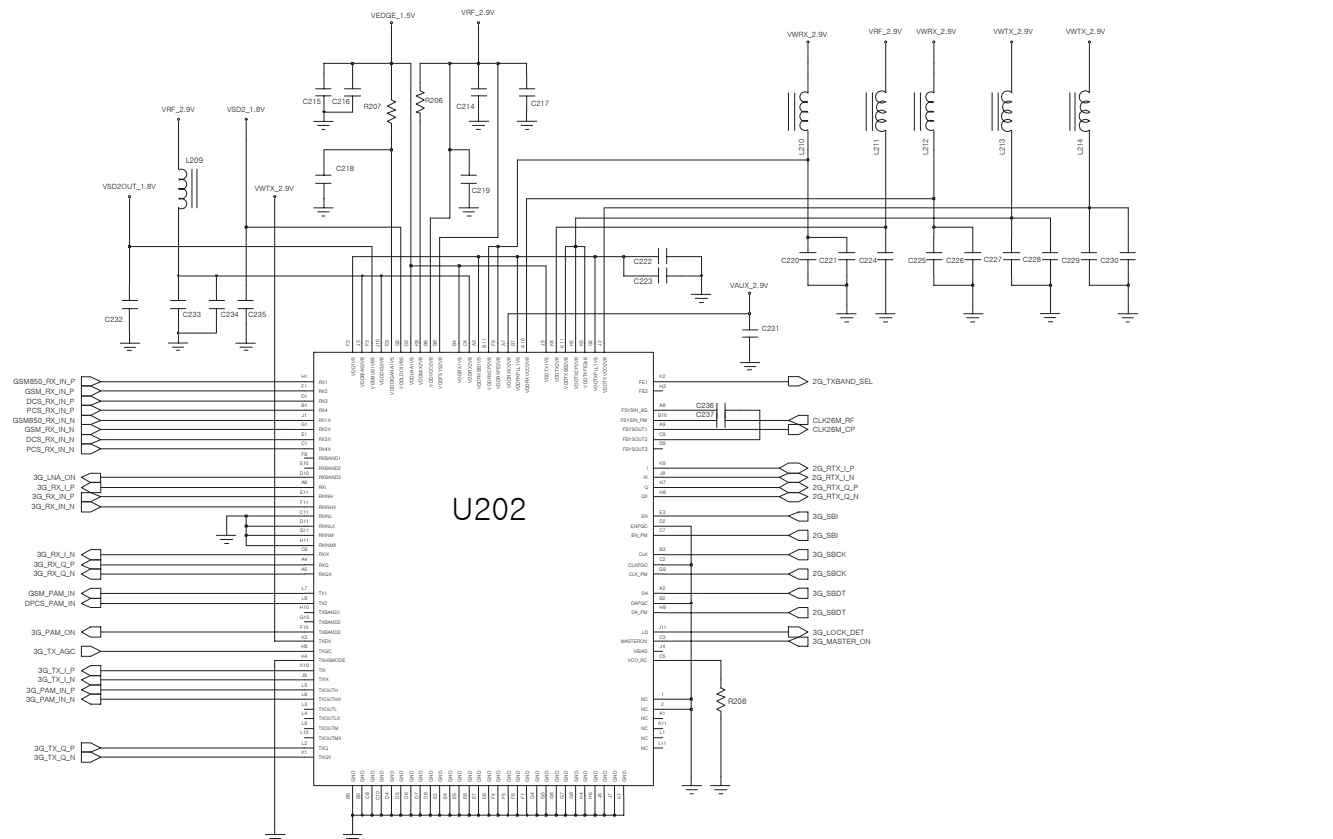
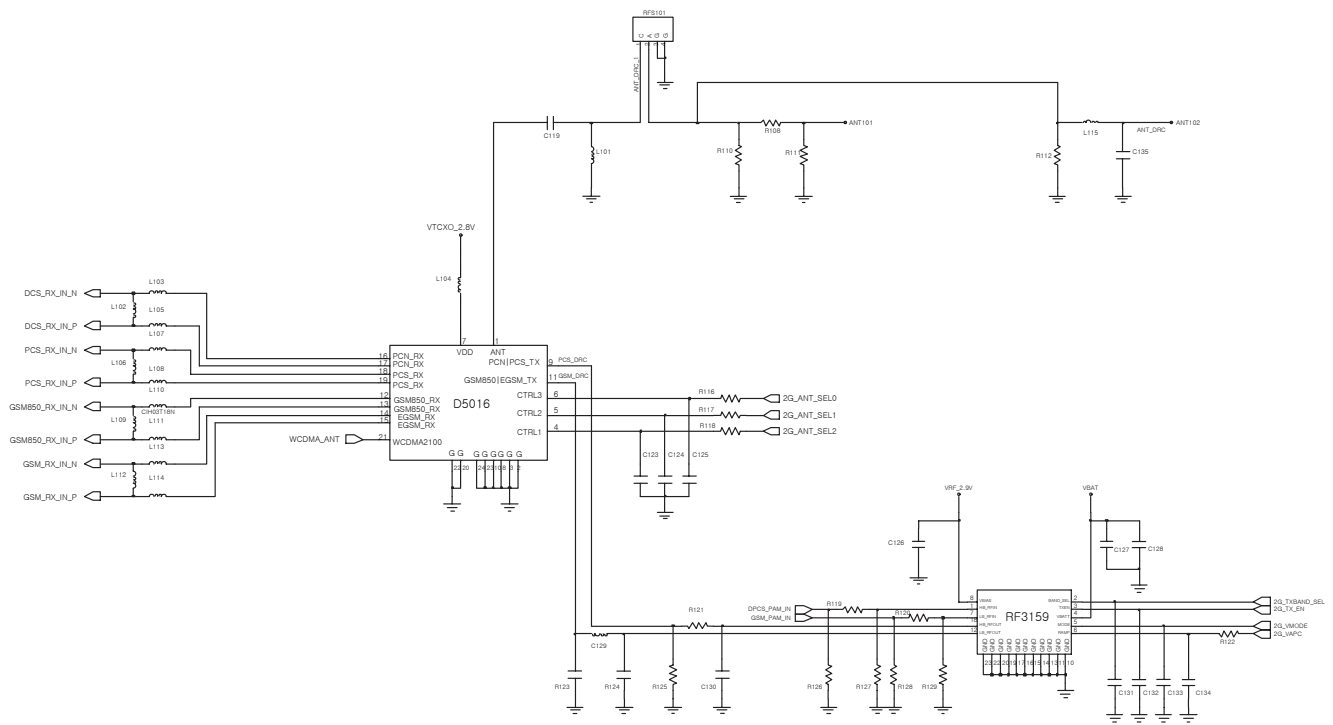

DCS RX Problem #1,2

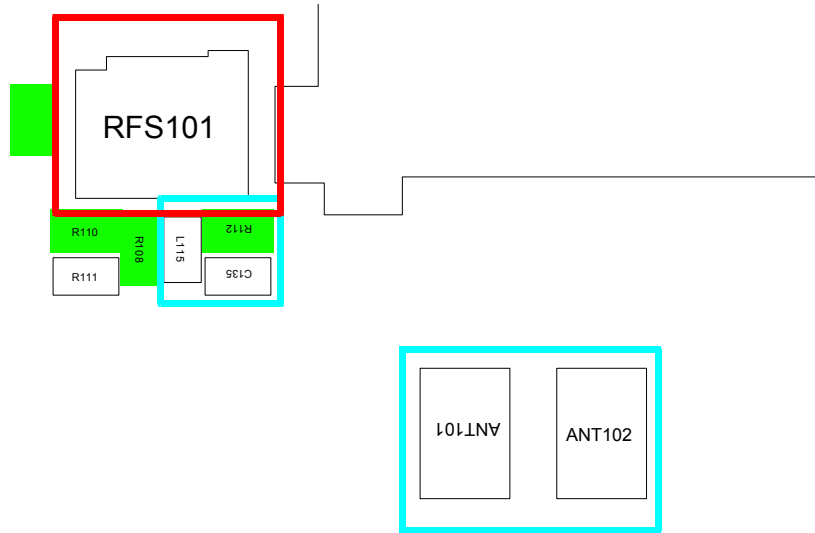

DCS RX Problem #3,4,5,6



9-2-3. PCS RX Part

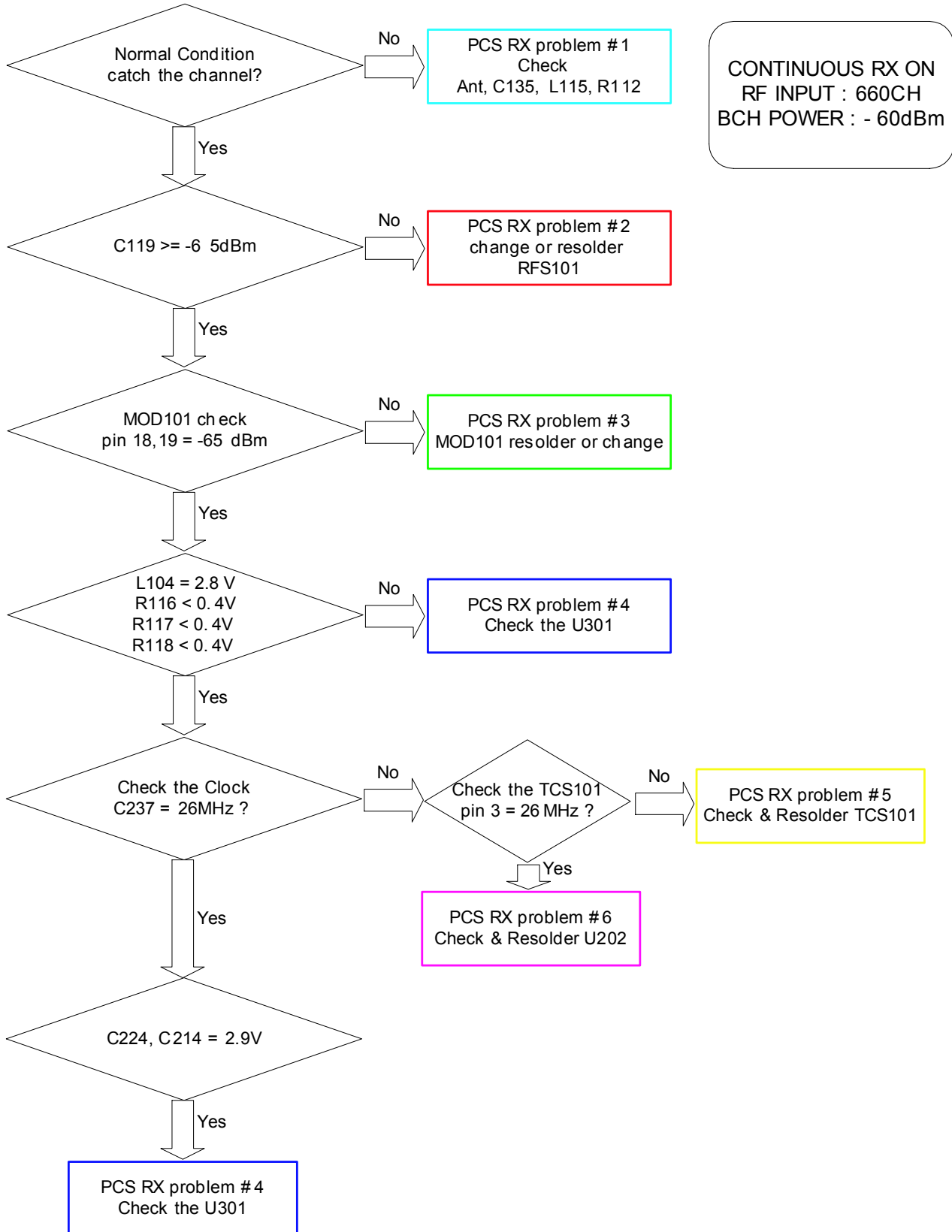

PCS RX Problem #1,2

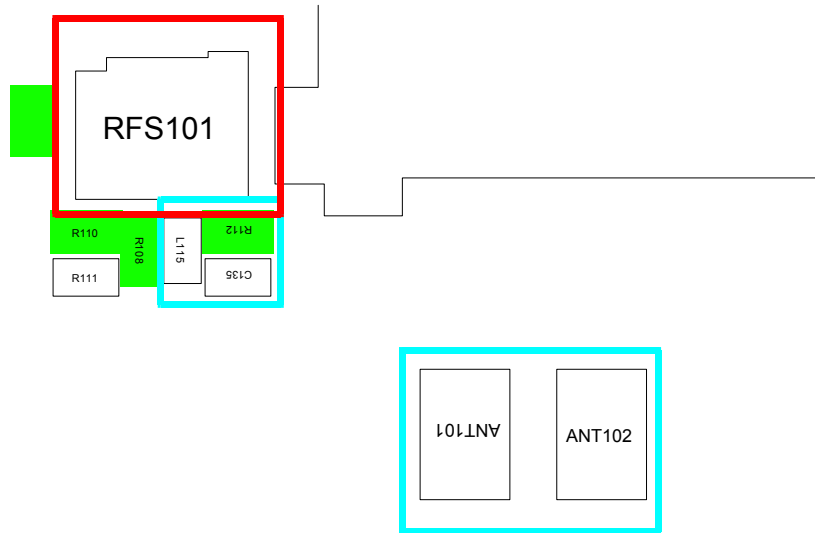

PCS RX Problem #3,4,5,6



9-2-4. EGSM TX Part

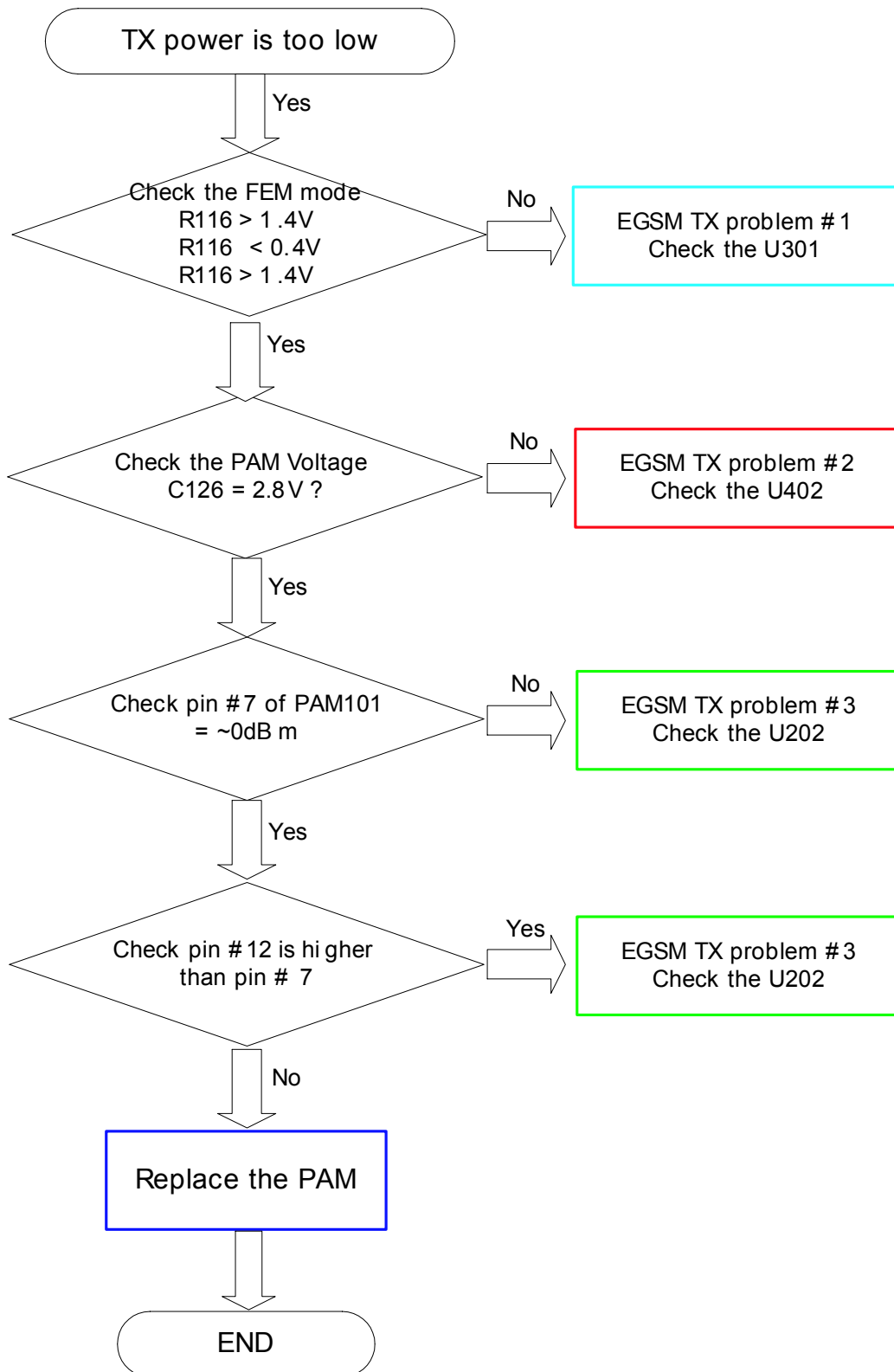

EGSM TX Problem #1,2,3

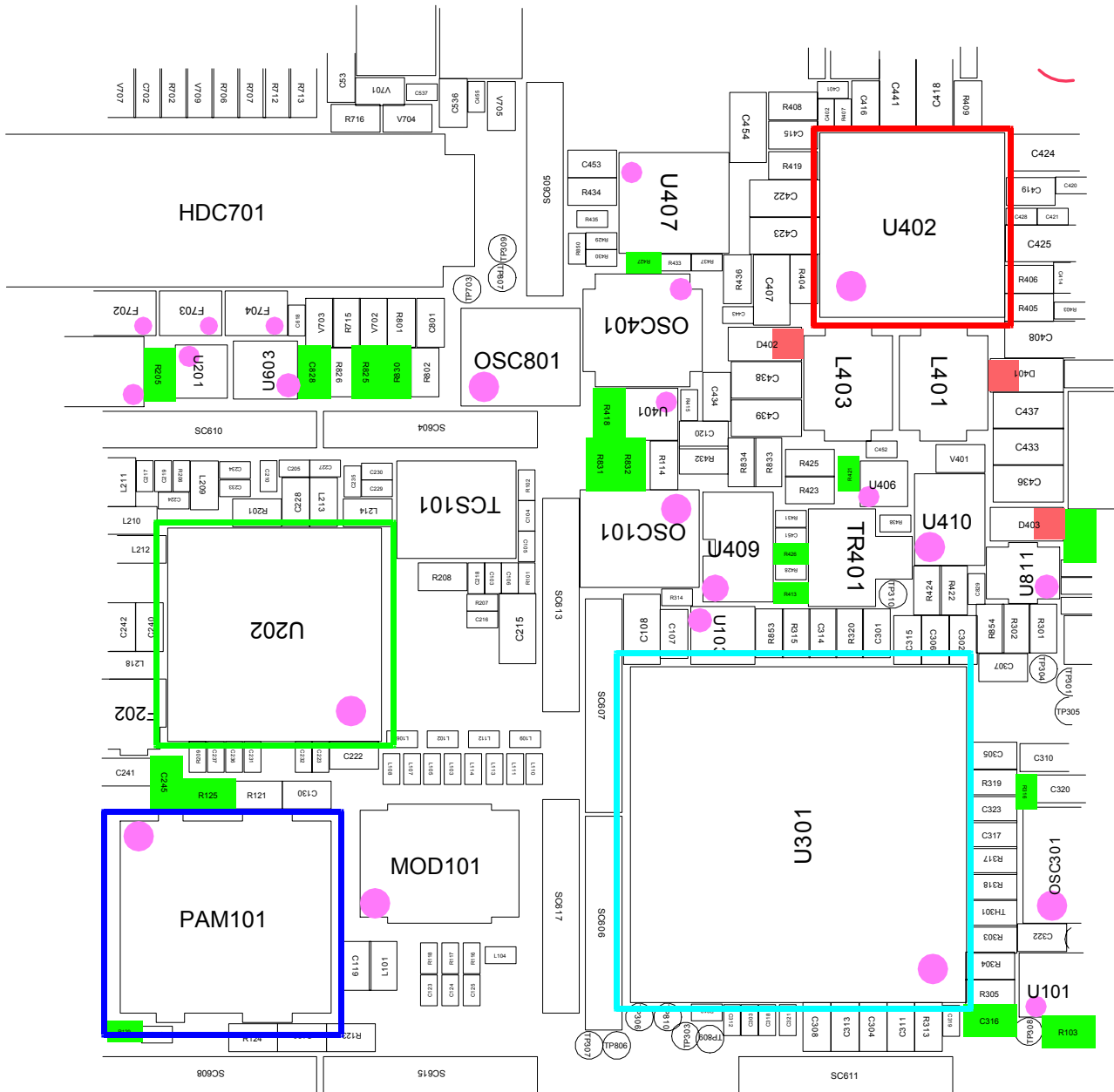

9-2-5. D/PCS TX Part

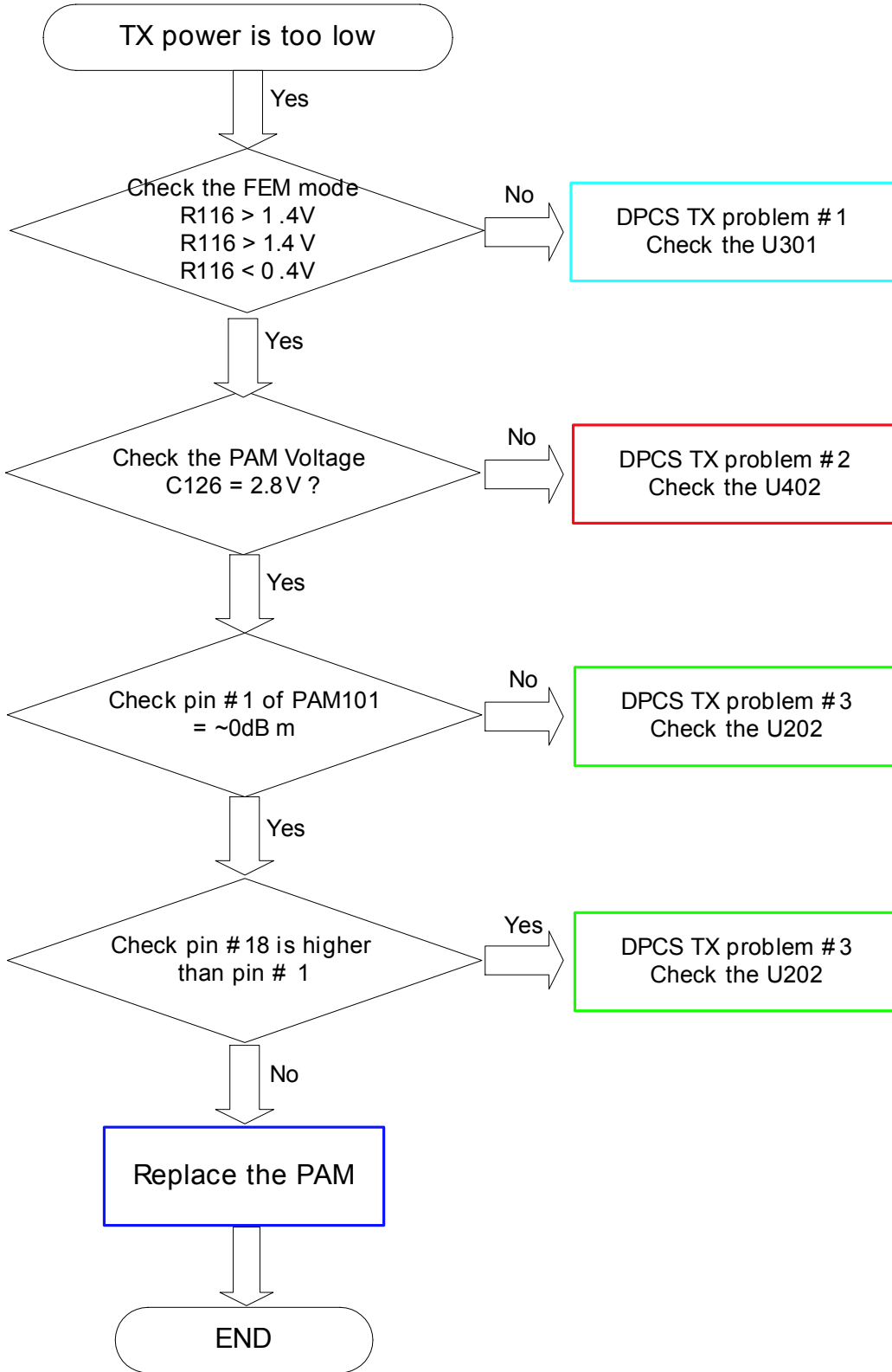

DPCS TX Problem #1,2,3

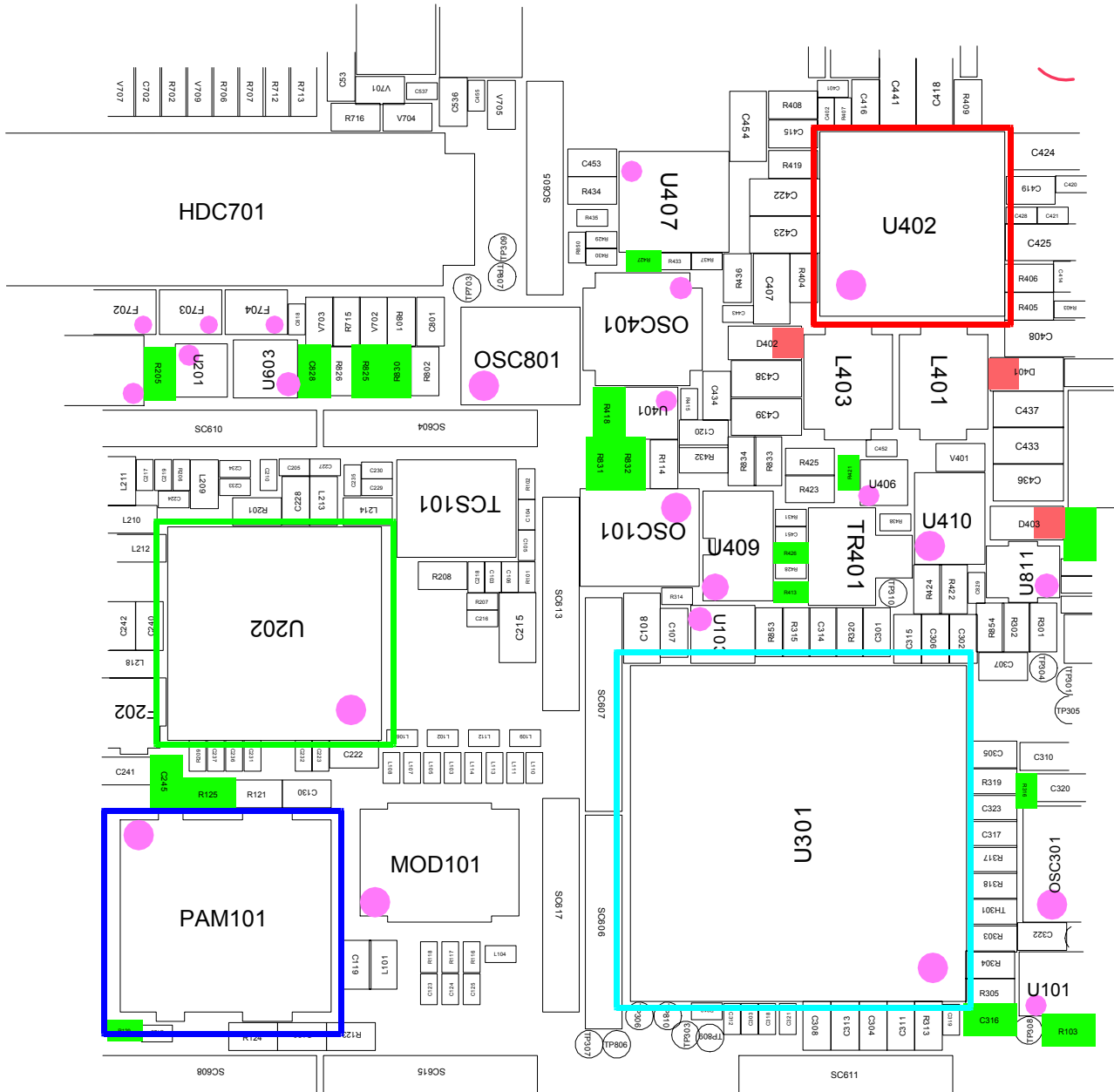

9-2-6. WCDMA RX Part

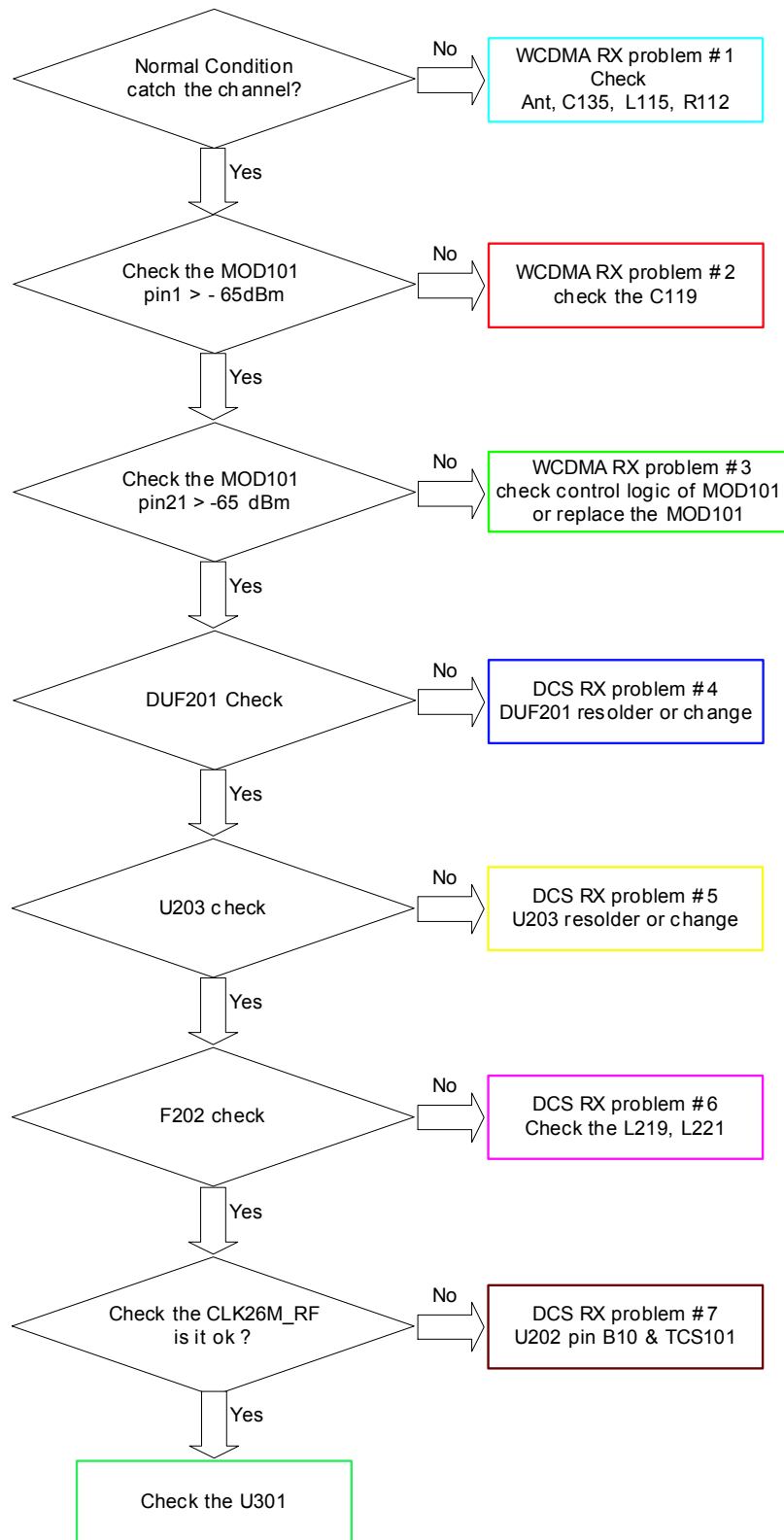

WCDMA RX Problem #1

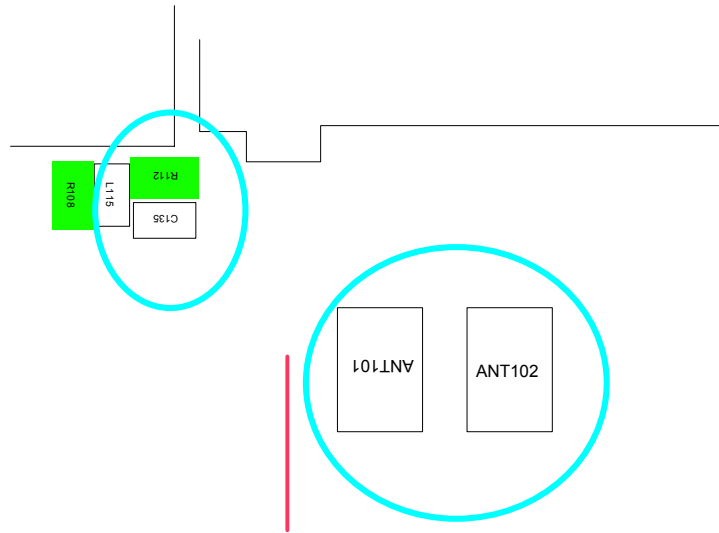

WCDMA RX Problem #2

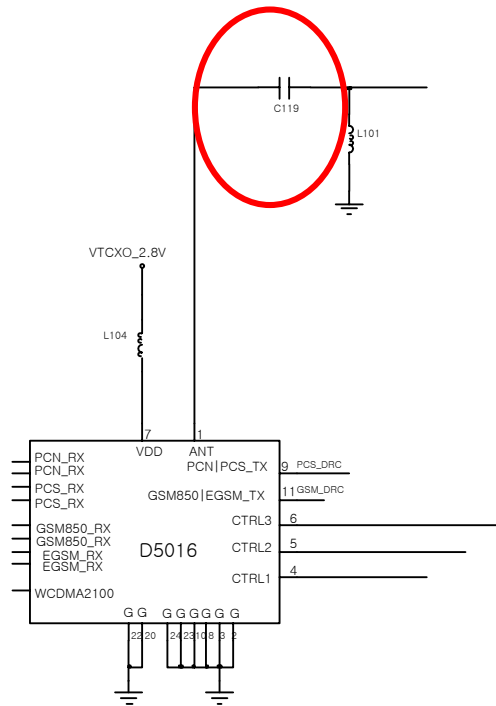

WCDMA RX Problem #3,4,5,6,7

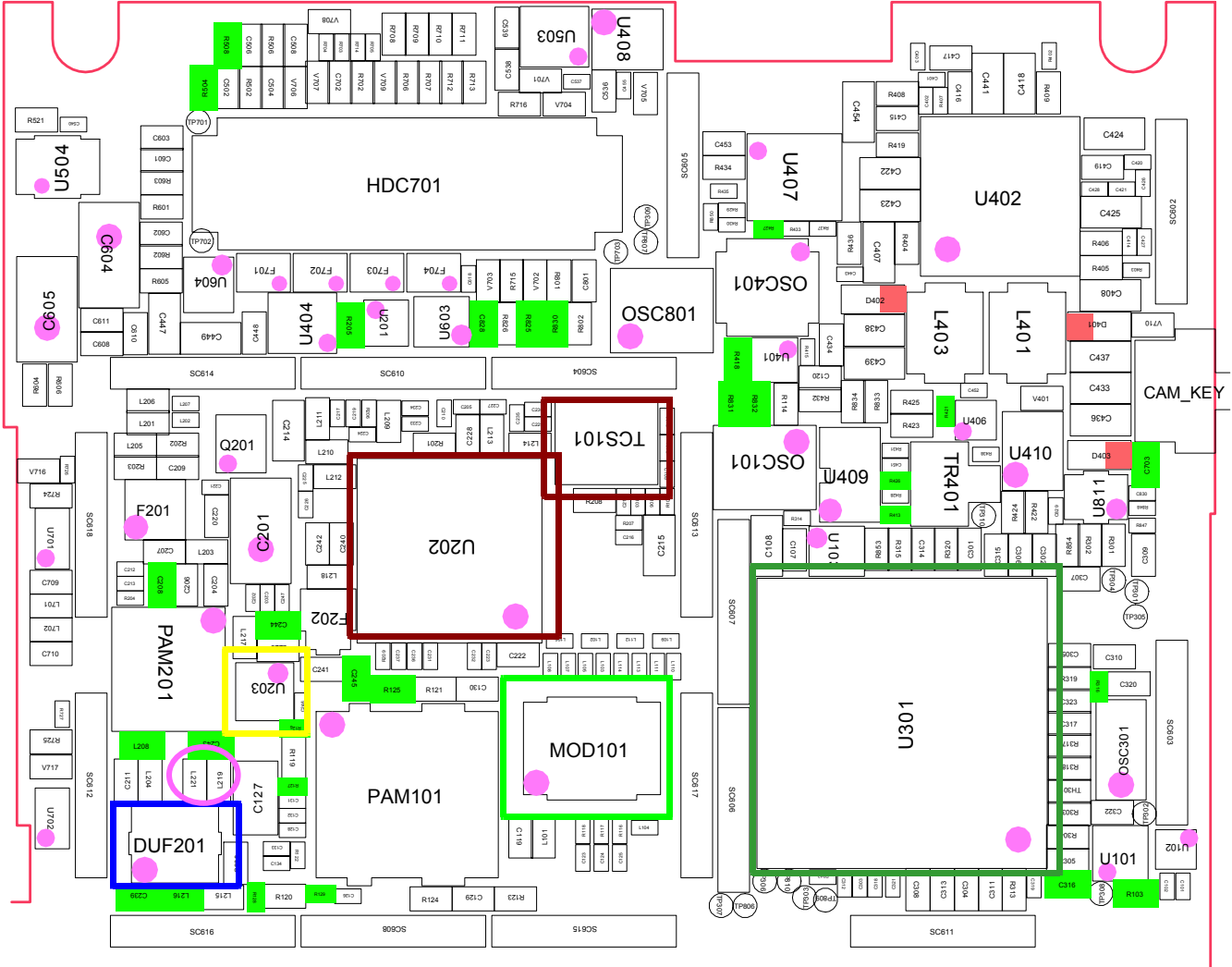

9-2-7. WCDMA Tx

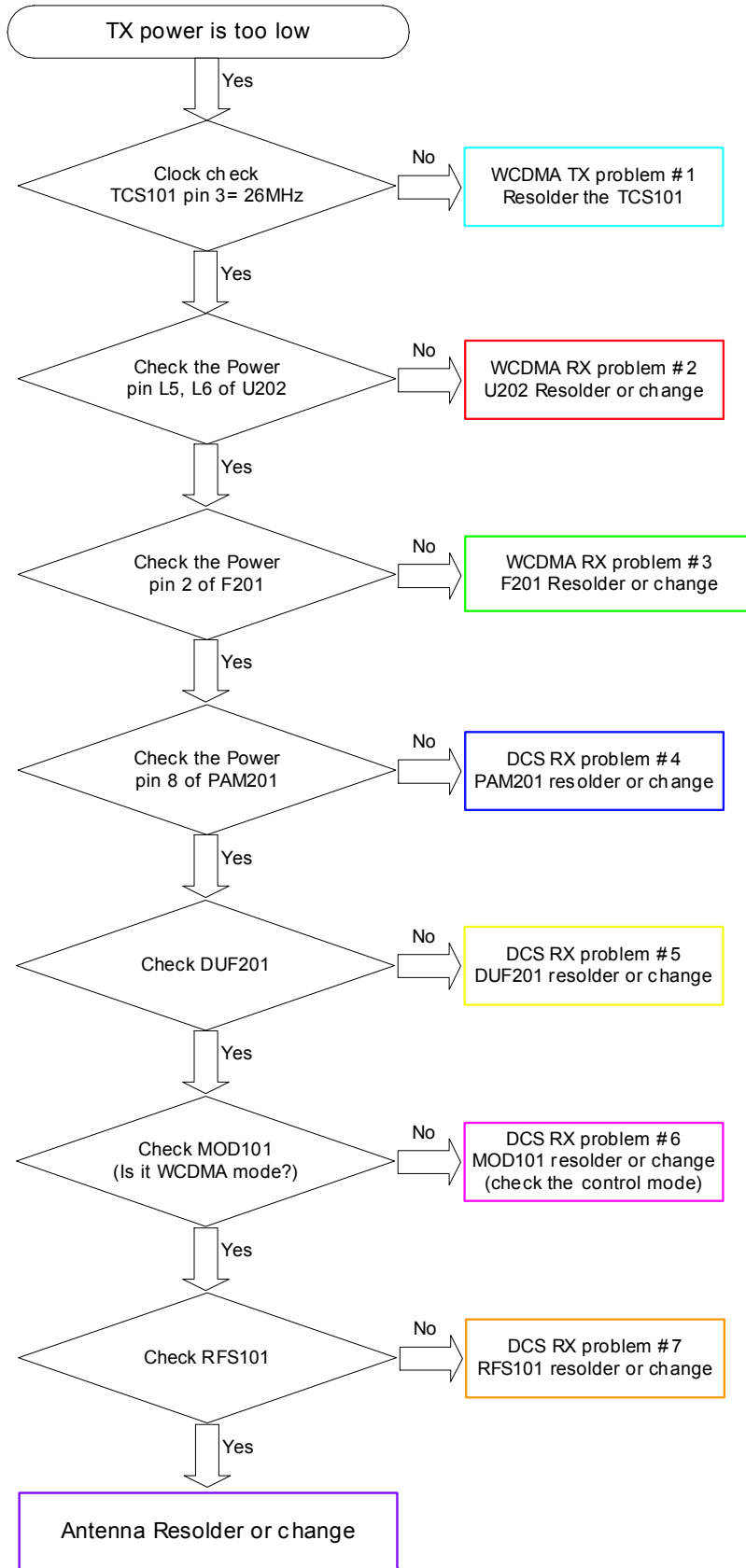

WCDMA RX Problem #1,2,3,4,5,6



WCDMA TX Problem #7,8

