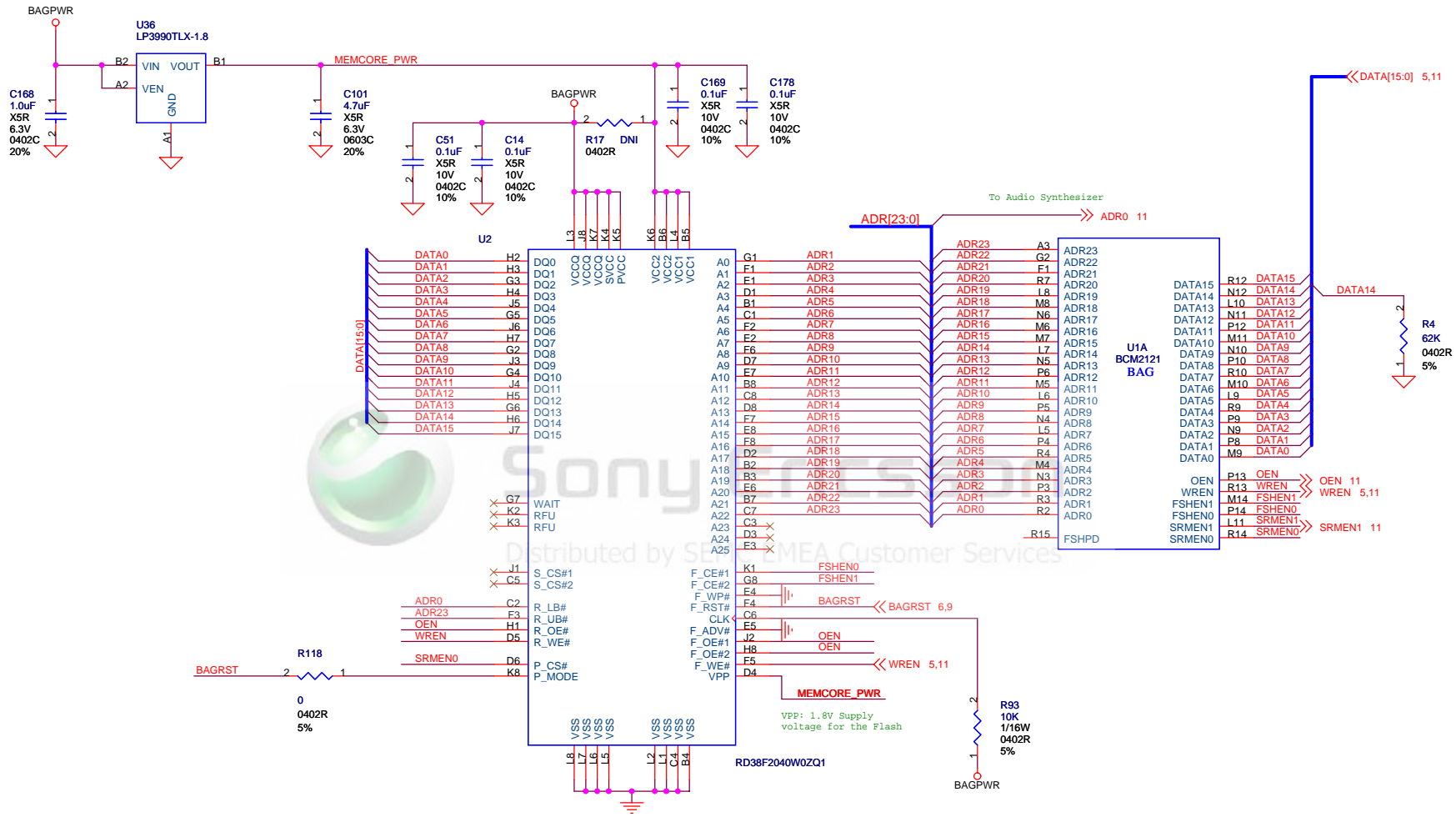

**Table of AUXADC[4:1] Usage**

- 1. AUXADC1: 32KHz Crystal Temperature
- 2. AUXADC2: Battery Charge Voltage Level
- 3. AUXADC3: LCM detection ID
- 4. AUXADC4: Temperature Sensor

Note: Input voltage range of AUXADC[4:1]: 0V to +1.2V

Broadcom Corporation 49 Discovery Irvine, CA 92618				<b>Broadcom Proprietary Information</b> All rights reserved. This document contains confidential trade secrets and is the proprietary property of Broadcom Corporation. This document shall not be used, copied, distributed or disclosed without the expressed written consent of Broadcom.	
<b>Title</b> Analog Voltage References					
<b>Size</b>	<b>Document Number</b>	<b>Rev</b>			
A	MTI-02272US (Moa)	P1A			
<b>Date:</b> Monday, April 11, 2005		<b>Sheet</b> 1	<b>of</b> 15		



ADR23 from ML2121 attached to support 128x32 memory for future upgrades. P/N reflects only 64x32 memory as currently required.

Broadcom Corporation 49 Discovery Irvine, CA 92618		<b>BROADCOM</b>		Broadcom Proprietary Information All rights reserved. This document contains confidential trade secrets and is the proprietary property of Broadcom Corporation. This document shall not be used, copied, distributed or disclosed without the expressed written consent of Broadcom.	
Title ARM Flash Memory, SRAM Interface					
Size	Document Number				Rev
B	MTI-02272US (Moa)				P1A
Date:	Monday, April 18, 2005	Sheet	2	of	15

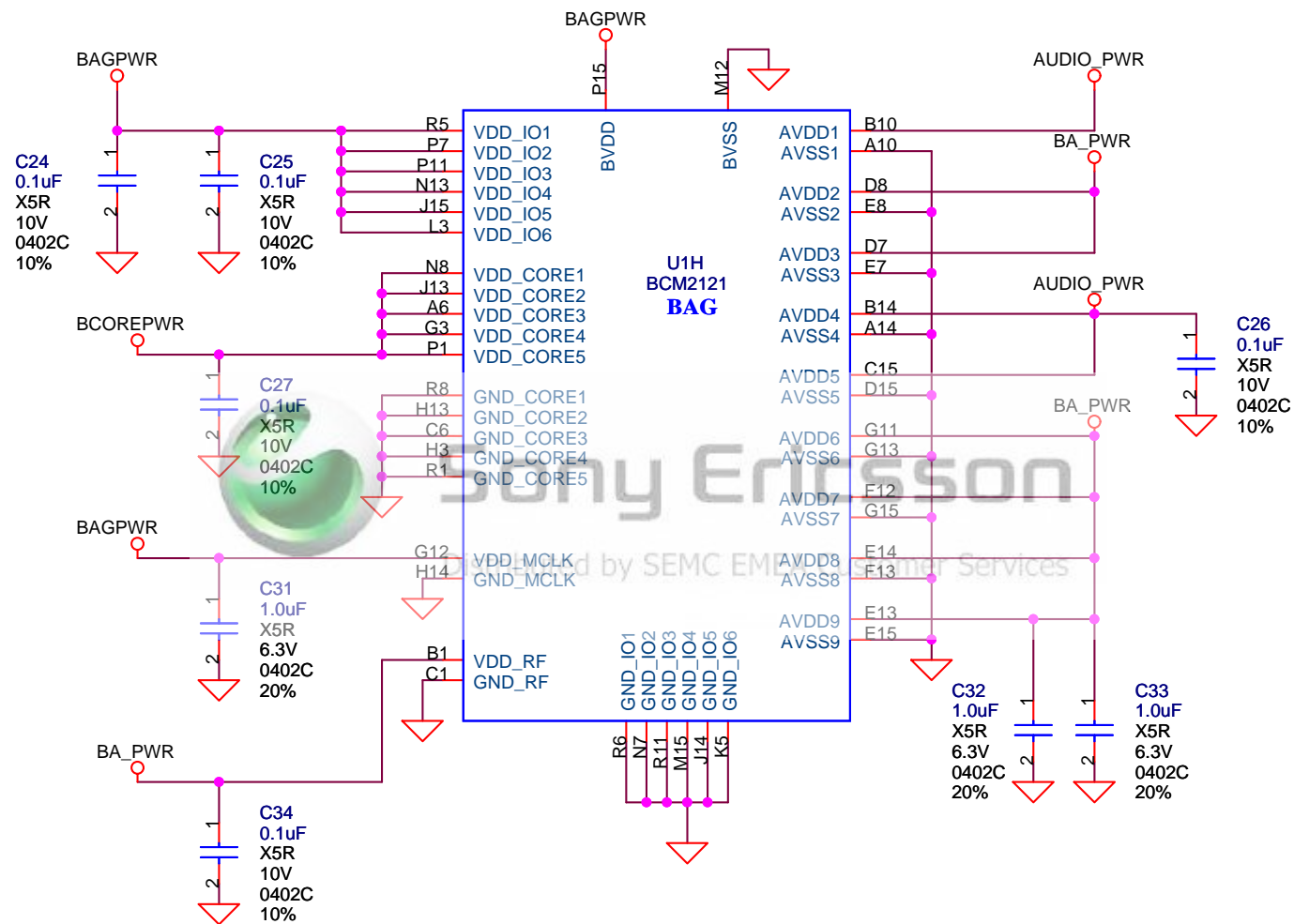

DVDD=Digital Power  
 DVSS=Digital Ground  
 AVDD=Analog Power  
 AVSS=Analog Ground

Broadcom Corporation  
 49 Discovery  
 Irvine, CA 92618



**Broadcom Proprietary Information**  
 All rights reserved. This document contains confidential trade secrets and is the proprietary property of Broadcom Corporation. This document shall not be used, copied, distributed or disclosed without the expressed written consent of Broadcom.

Title  
 BAG Power

Size A Document Number  
 MTI-02272US (Moa)

Rev  
 P1A

Date: Thursday, March 31, 2005 Sheet 3 of 15

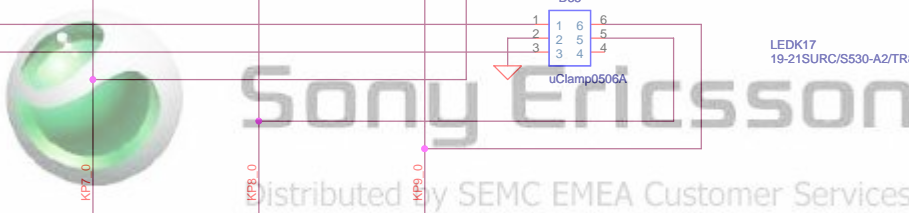
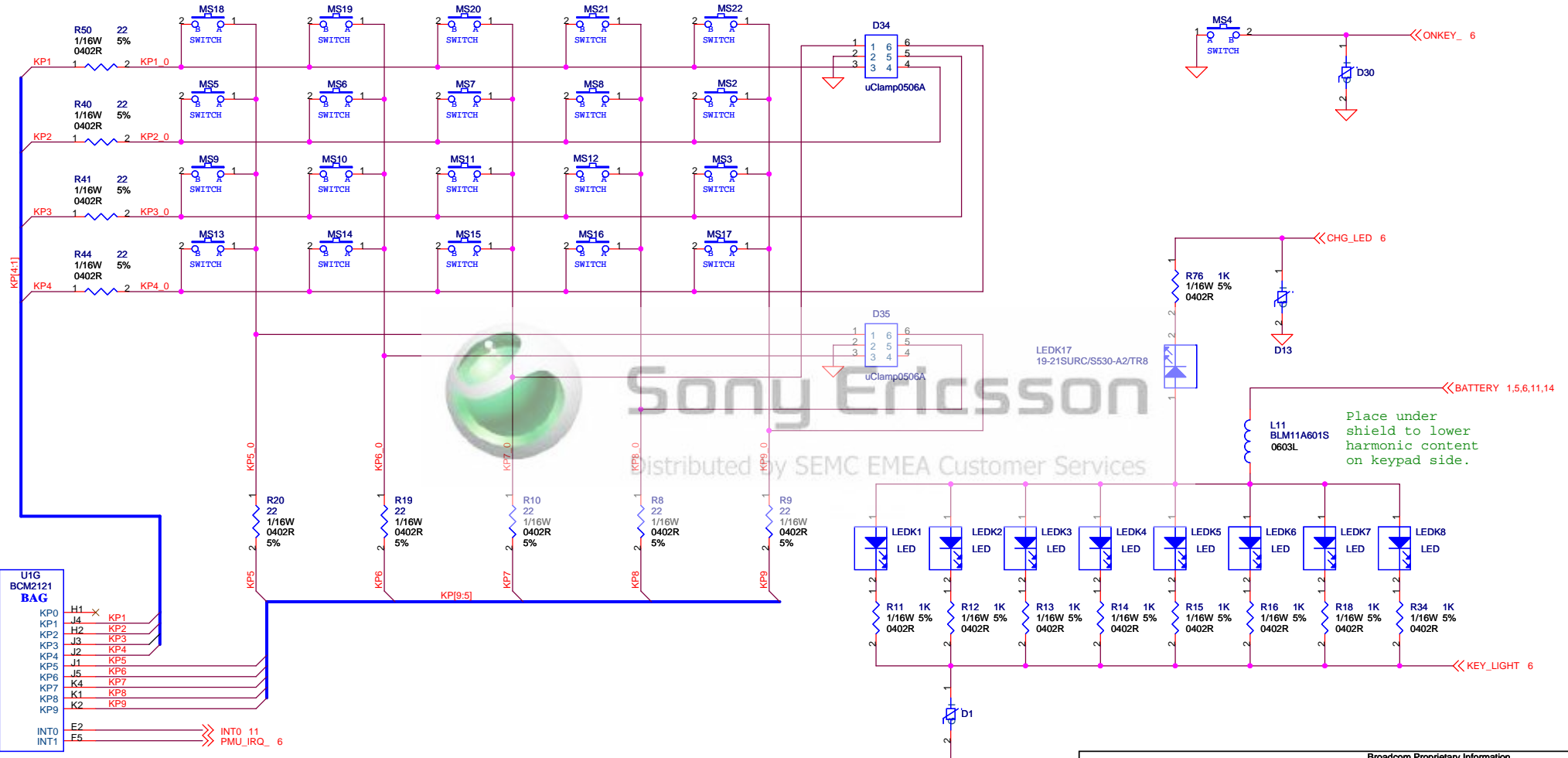

Place under shield to lower harmonic content on keypad side.

**Broadcom Corporation**  
49 Discovery  
Irvine, CA 92618

**BROADCOM**

**Broadcom Proprietary Information**  
All rights reserved. This document contains confidential trade secrets and is the proprietary property of Broadcom Corporation. This document shall not be used, copied, distributed or disclosed without the expressed written consent of Broadcom.

Title Keypad Interface		
Size B	Document Number MTI-02272US (Moa)	Rev P1A
Date: Tuesday, April 19, 2005	Sheet 4 of 15	





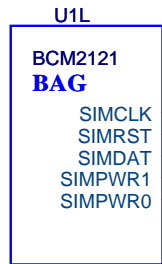

Sony Ericsson  
 Distributed by SEMC EMEA Customer Services

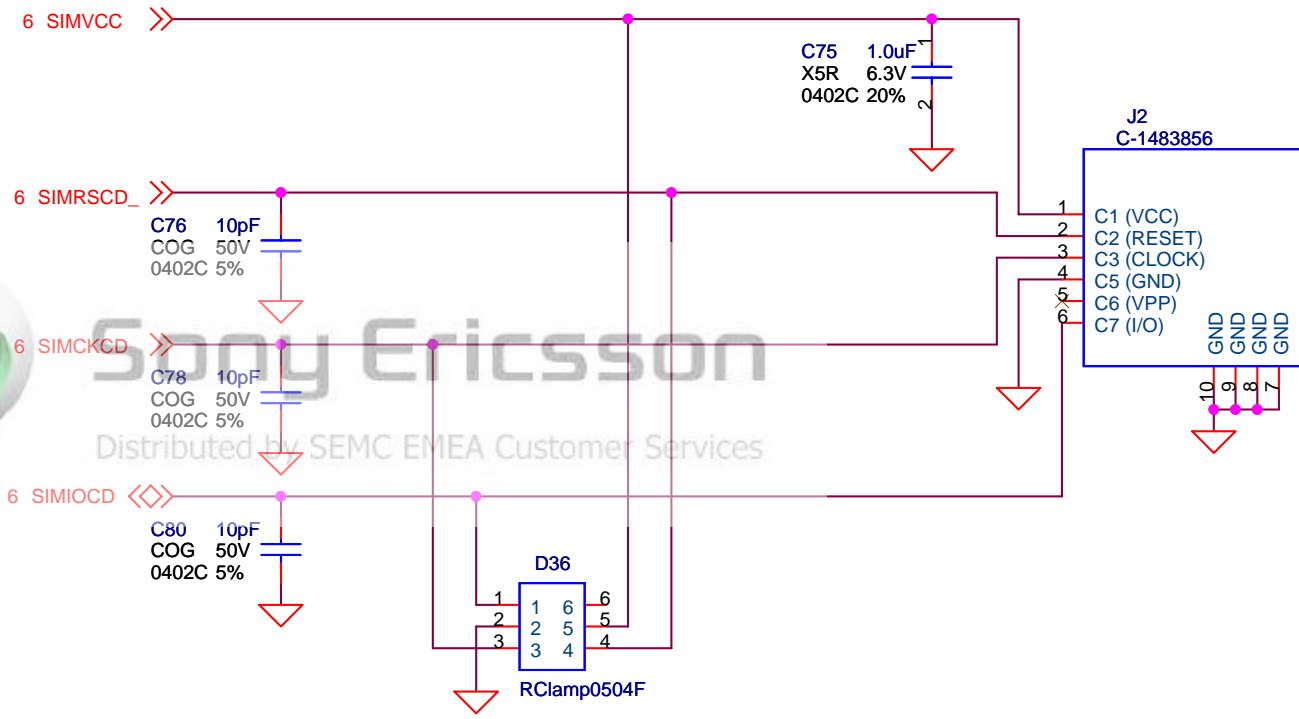

**Broadcom Proprietary Information**  
 All rights reserved. This document contains confidential trade secrets and is the proprietary property of Broadcom Corporation. This document shall not be used, copied, distributed or disclosed without the expressed written consent of Broadcom.

**BROADCOM**

**Broadcom Corporation**  
 49 Discovery  
 Irvine, CA 92618

**Title**  
 SIM Card Interface

<b>Size</b> A	<b>Document Number</b> MTI-02272US (Moa)	<b>Rev</b> P1A
------------------	---------------------------------------------	-------------------

**Date:** Monday, April 11, 2005 **Sheet** 7 **of** 15

Note: EXTID[2:0] are internally pulled-down.

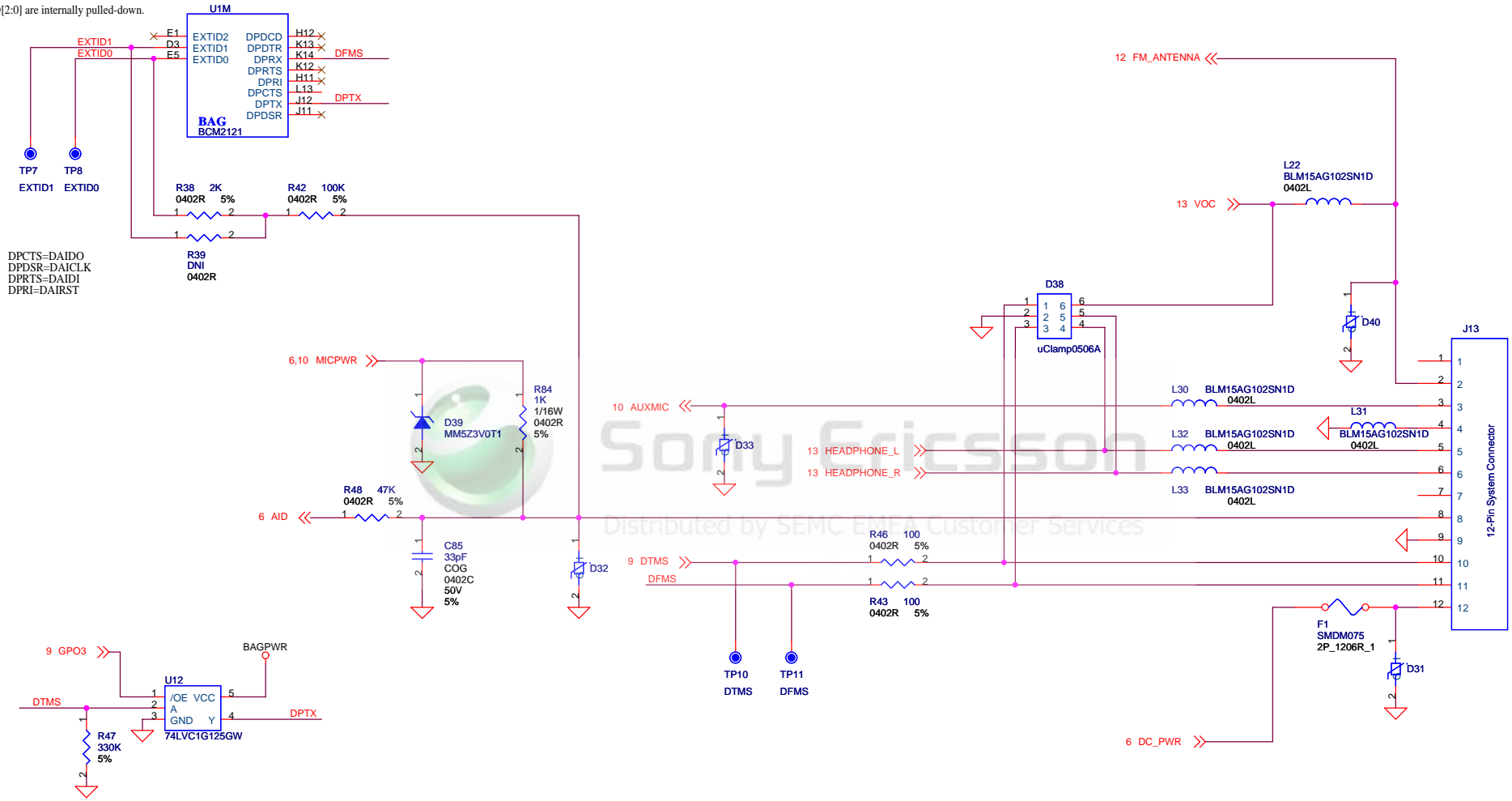

Broadcom Corporation 49 Discovery Irvine, CA 92618				Broadcom Proprietary Information All rights reserved. This document contains confidential trade secrets and is the proprietary property of Broadcom Corporation. This document shall not be used, copied, distributed or disclosed without the expressed written consent of Broadcom.	
Title: System Connector Interface					
Size: B	Document Number: MTI-02272US (Moa)				Rev: P1A
Date: Monday, April 18, 2005	Sheet: 8 of 15				



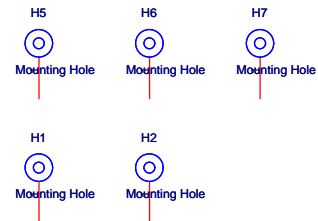
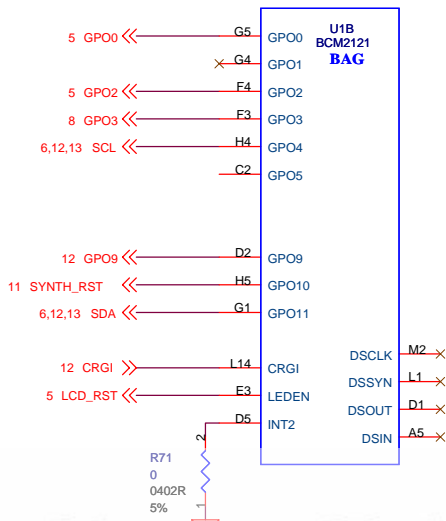
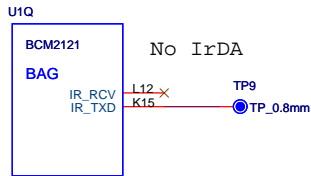

Sony Ericsson

Distributed by SEMC EMEA Customer Services

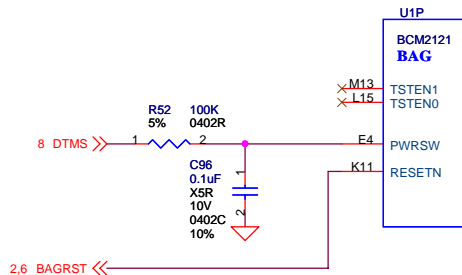
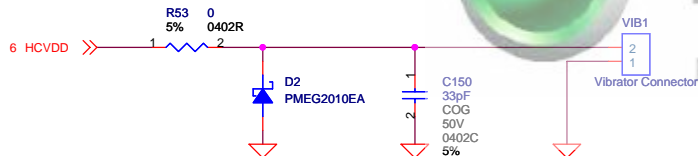

Broadcom Corporation 49 Discovery Irvine, CA 92618			Broadcom Proprietary Information All rights reserved. This document contains confidential trade secrets and is the proprietary property of Broadcom Corporation. This document shall not be used, copied, distributed or disclosed without the expressed written consent of Broadcom.
Title Transducer, LED & LCD Front Light			
Size B	Document Number MTI-02272US (Moa)	Rev P1A	
Date:	Tuesday, April 19, 2005	Sheet	9 of 15

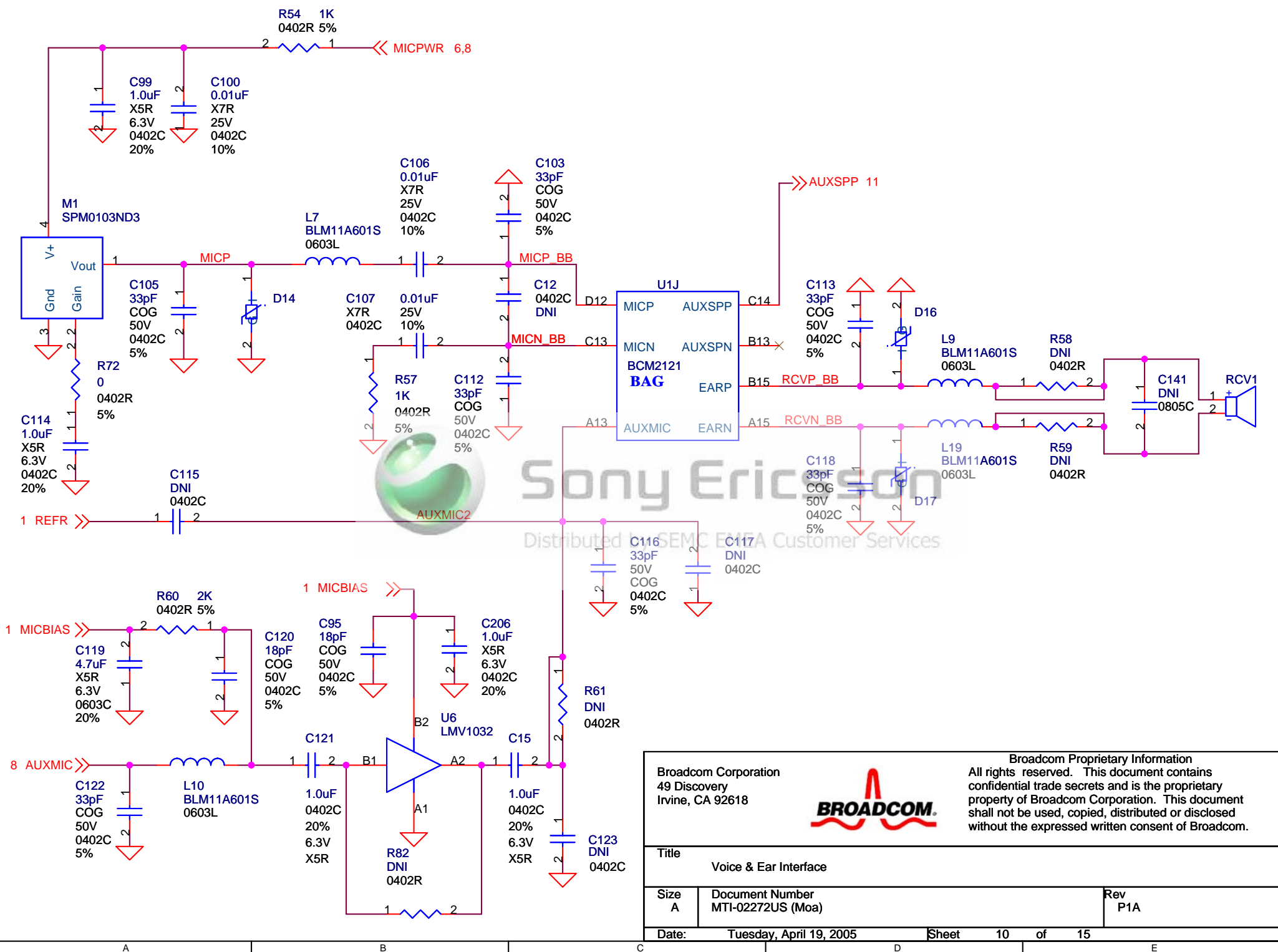

Broadcom Proprietary Information  
All rights reserved. This document contains confidential trade secrets and is the proprietary property of Broadcom Corporation. This document shall not be used, copied, distributed or disclosed without the expressed written consent of Broadcom.



Broadcom Corporation  
49 Discovery  
Irvine, CA 92618

Title Voice & Ear Interface		
Size A	Document Number MTI-02272US (Moa)	Rev P1A
Date:	Tuesday, April 19, 2005	Sheet 10 of 15

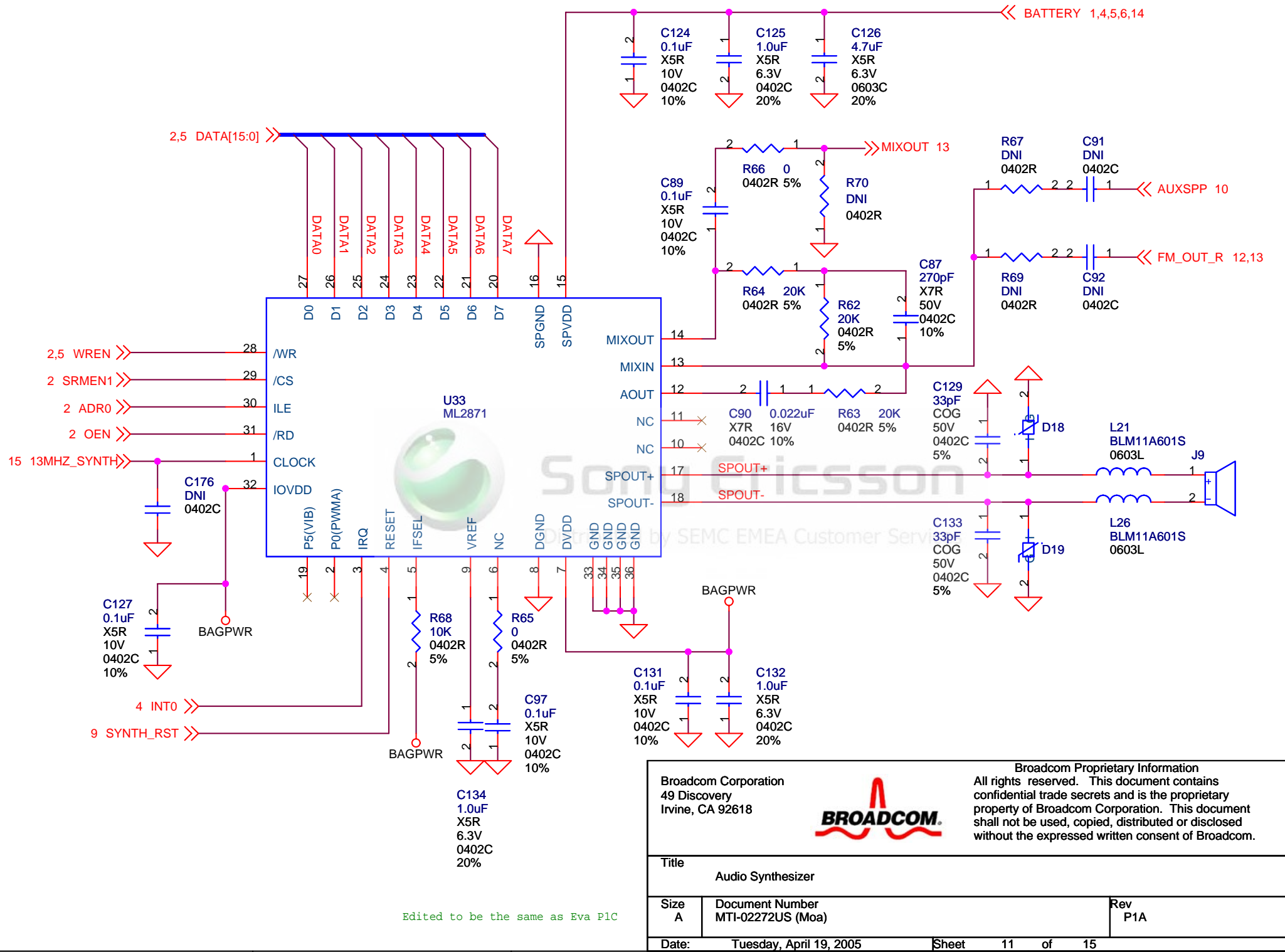

Edited to be the same as Eva P1C

Broadcom Proprietary Information  
 All rights reserved. This document contains confidential trade secrets and is the proprietary property of Broadcom Corporation. This document shall not be used, copied, distributed or disclosed without the expressed written consent of Broadcom.

**BROADCOM**

Title  
 Audio Synthesizer

Size A	Document Number MTI-02272US (Moa)	Rev P1A
-----------	--------------------------------------	------------

Date: Tuesday, April 19, 2005 Sheet 11 of 15

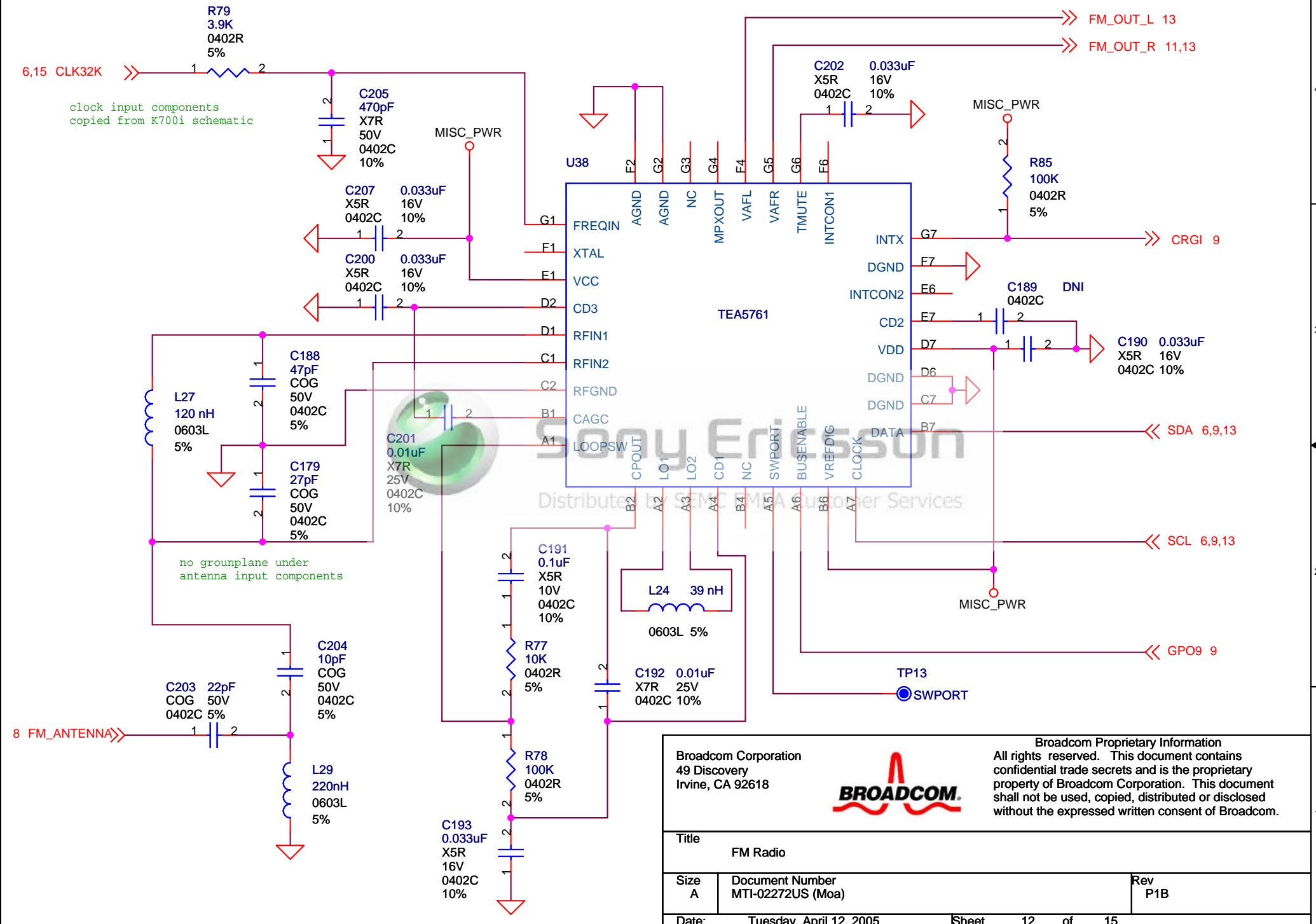

**Broadcom Proprietary Information**  
 All rights reserved. This document contains confidential trade secrets and is the proprietary property of Broadcom Corporation. This document shall not be used, copied, distributed or disclosed without the expressed written consent of Broadcom.

**Broadcom Corporation**  
 49 Discovery  
 Irvine, CA 92618



**Title**  
 FM Radio

<b>Size</b> A	<b>Document Number</b> MTI-02272US (Moa)	<b>Rev</b> P1B
------------------	---------------------------------------------	-------------------

**Date:** Tuesday, April 12, 2005 **Sheet** 12 **of** 15

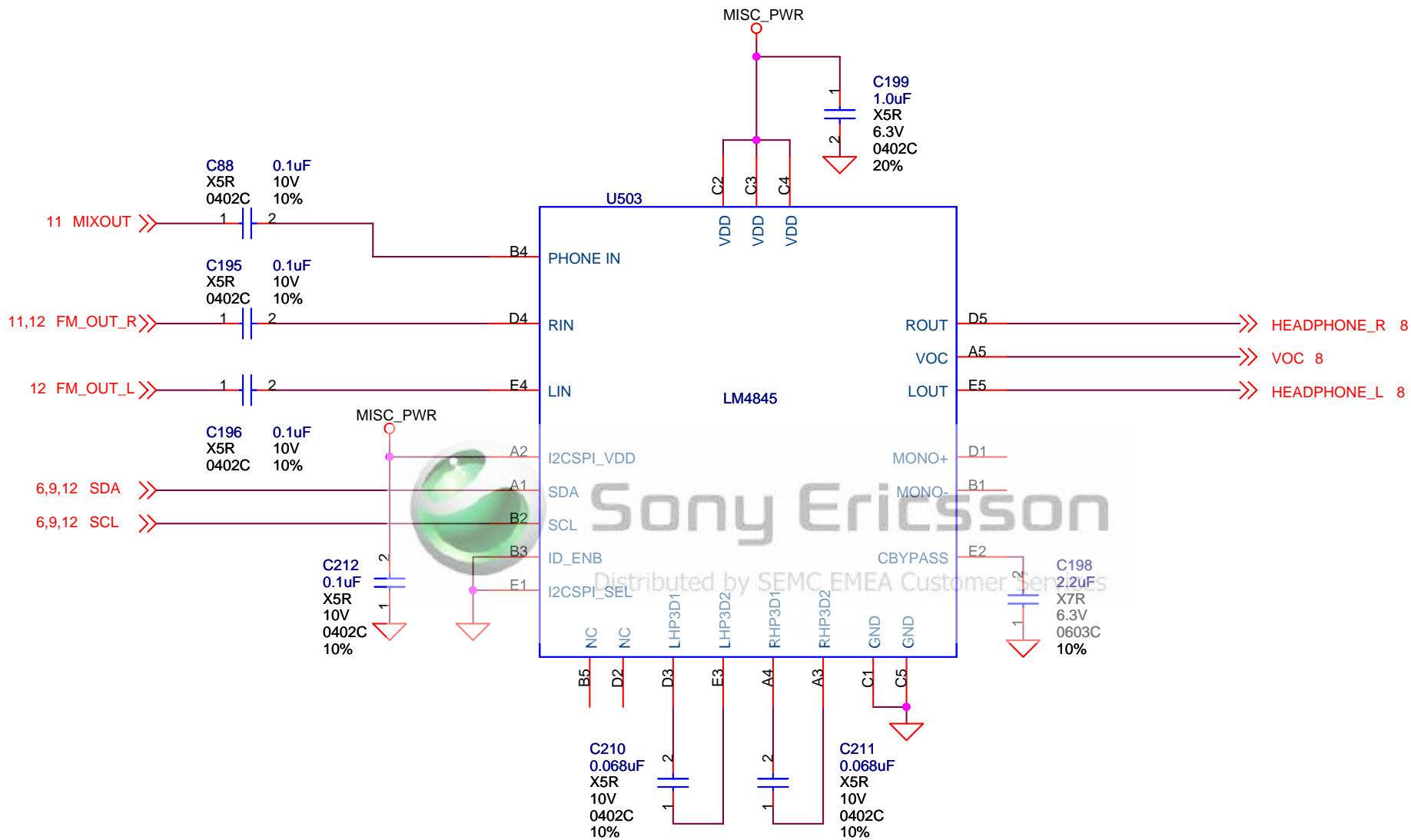

Broadcom Corporation  
49 Discovery  
Irvine, CA 92618



**Broadcom Proprietary Information**  
All rights reserved. This document contains confidential trade secrets and is the proprietary property of Broadcom Corporation. This document shall not be used, copied, distributed or disclosed without the expressed written consent of Broadcom.

Title  
Audio Amplifier

Size A	Document Number MTI-02272US (Moa)	Rev P1A
-----------	--------------------------------------	------------

Date: Tuesday, April 19, 2005 Sheet 13 of 15

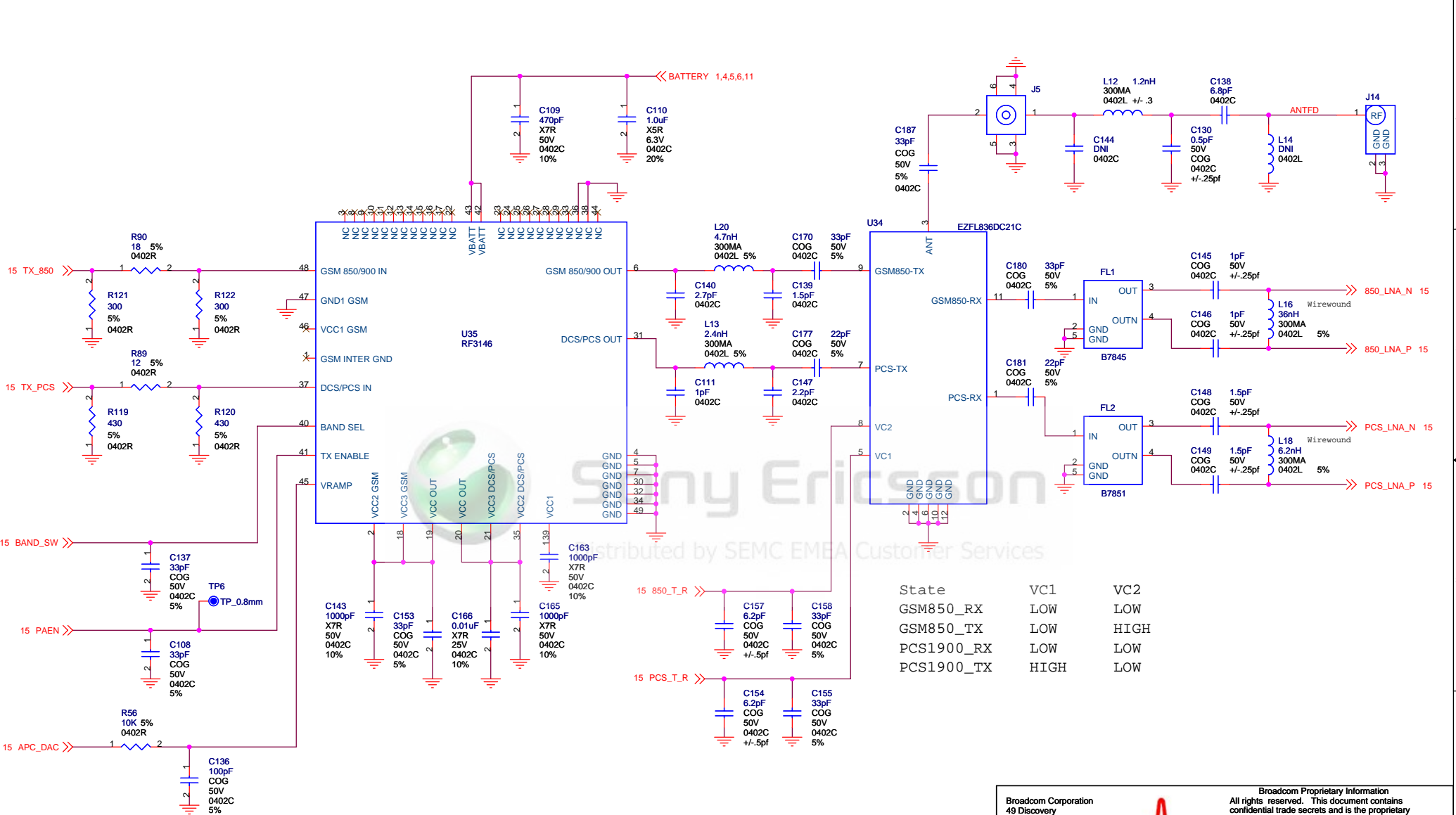

check ramp voltage output from BB and input to PA

State	VC1	VC2
GSM850_RX	LOW	LOW
GSM850_TX	LOW	HIGH
PCS1900_RX	LOW	LOW
PCS1900_TX	HIGH	LOW

# PA and Front End

Broadcom Corporation 49 Discovery Irvine, CA 92618				<b>Broadcom Proprietary Information</b> All rights reserved. This document contains confidential trade secrets and is the proprietary property of Broadcom Corporation. This document shall not be used, copied, distributed or disclosed without the expressed written consent of Broadcom.	
Title: RF PA & Front End					
Size: B	Document Number: MTI-02272US (Moa)				Rev: P1A
Date: Monday, April 18, 2005	Sheet: 14 of 15				

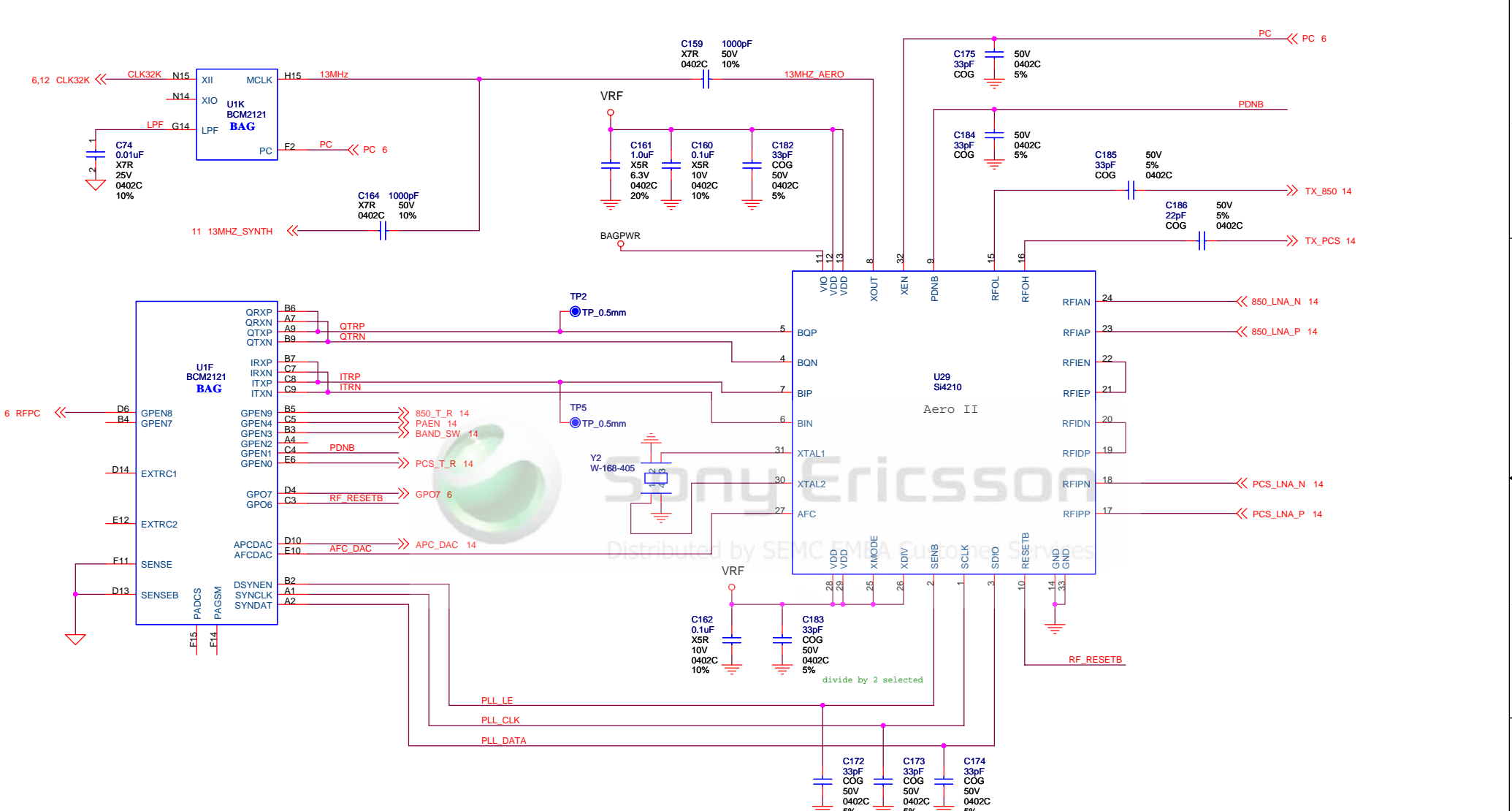

# Transceiver

Broadcom Corporation 49 Discovery Irvine, CA 92618				<b>Broadcom Proprietary Information</b> All rights reserved. This document contains confidential trade secrets and is the proprietary property of Broadcom Corporation. This document shall not be used, copied, distributed or disclosed without the expressed written consent of Broadcom.	
Title					
RF Transceiver					
Size	Document Number				Rev
B	MTI-02272US (Moa)				P1A
Date:	Monday, April 11, 2005		Sheet	15	of 15